

**STANDARD DETAILS**  
**TRI General Improvement District**

**McCarran, Nevada**

**May 2024**



TRI General Improvement District  
440 USA Parkway, Suite 105  
McCarran, Nevada 89437

**INDEX**

**TAHOE RENO INDUSTRIAL GENERAL IMPROVEMENT DISTRICT STANDARD DETAIL**

SHEET  
NUMBER

SHEET TITLE

REVISION  
DATE

**SECTION 2.0 WATER DETAILS**

- 2.1.1 FLANGED TEE – FLG X MJ – RESTRAINED
- 2.1.2 FLANGED TEE – FLG X PUSH ON
- 2.1.3 GATE VALVE – FLG X MJ – RESTRAINED
- 2.1.4 GATE VALVE – MJ X PUSH ON
- 2.1.5 GATE VALVE – FLG X PUSH ON
- 2.2.1 COUPLING
- 2.3.1 WATER TAPPING SLEEVE
- 2.3.2 STANDARD TAP 4” TO 12”
- 2.3.3 REVERSE TAP 4” TO 12”
- 2.4.1 REDUCED PRESSURE PRINCIPLE ASSEMBLY, EXTERNAL, HORIZONTAL
- 2.4.2 FIRE – CLASS 1, 2, & 3, DOUBLE CHECK VALVE DETECTOR, EXTERNAL, HORIZONTAL, BELOW GRADE
- 2.4.3 FIRE – CLASS 1, 2, & 3, DOUBLE CHECK VALVE DETECTOR, EXTERNAL, HORIZONTAL, ABOVE GRADE
- 2.4.4 FIRE – CLASS 1, 2, & 3, DOUBLE CHECK VALVE DETECTOR, INTERNAL, VERTICAL
- 2.4.5 FIRE – CLASS 1, 2, & 3, DOUBLE CHECK VALVE DETECTOR, INTERNAL, HORIZONTAL
- 2.4.6 FIRE – CLASS 1, 2, & 3, DOUBLE CHECK VALVE DETECTOR, INTERNAL, BASEMENT INSTALLATION
- 2.4.7 FIRE – CLASS 4, 5, & 6, DOUBLE CHECK VALVE DETECTOR, EXTERNAL, HORIZONTAL
- 2.4.8 FIRE – CLASS 4, 5, & 6, DOUBLE CHECK VALVE DETECTOR, INTERNAL, HORIZONTAL
- 2.4.9 FIRE – CLASS 1 – 6 CONTINUOUS FLOW SERVICES, MANIFOLD FOR PARALLEL BACKFLOW ASSEMBLIES
- 2.4.10 AIR GAP SEPARATION
- 2.5.1 PERMANENT DEAD-END LOCATION FLUSH ASSEMBLY



DRAWN: \_\_\_\_\_ NT  
 CHECKED: \_\_\_\_\_ CLR  
 REV: \_\_\_\_\_ SEPT 2024  
 REV: \_\_\_\_\_

STANDARD DETAIL

INDEX

**INDEX**

**1.1**

SHEET  
NUMBER

SHEET TITLE

REVISION  
DATE

2.5.2	TEMPORARY DEAD-END FLUSH ASSEMBLY	
2.5.3	BLOW-OFF ASSEMBLY	
2.5.4	IN-LINE FLUSH ASSEMBLY	
2.5.5	FLUSH ASSEMBLY FOR CONSTRUCTION WATER SERVICE	
2.6.1	6" FIRE HYDRANT SERVICE OFF NEW MAINS	
2.6.2	FIRE SERVICE OFF NEW MAINS	
2.6.3	6" FIRE HYDRANT SERVICE OFF EXISTING MAIN	
2.6.4	FIRE SERVICE OFF EXISTING MAIN	
2.8.1	1" TO 2" SERVICE TAP	
2.9.1	RESTRAINED JOINT VERTICAL OFFSET UNDER UTILITY/OBJECT	
2.9.2	RESTRAINED JOINT VERTICAL OFFSET OVER UTILITY/OBJECT	
2.9.3	RESTRAINED JOINT SINGLE VERTICAL OFFSET	
2.10.1	IN-LINE GATE VALVE WITH CONCRETE COLLAR	
2.11.1	NEW COMMERCIAL INSTALL – 1" SINGLE SERVICE FOR 3/4" SETTER, METER, AND TRANSMITTER	9/10/2024
2.11.2	NEW COMMERCIAL INSTALL – 1-1/2" SINGLE SERVICE FOR 1-1/2" SETTER, METER, AND TRANSMITTER	9/10/2024
2.11.3	NEW COMMERCIAL INSTALL – 2" SINGLE SERVICE FOR 2" SETTER, METER, AND TRANSMITTER	9/10/2024
2.11.4	NEW COMMERCIAL INSTALL – 1" DUAL SERVICE FOR 3/4" SETTER, METER, AND TRANSMITTER	9/10/2024
2.11.5	RETROFIT INSTALL – 1" SINGLE SERVICE FOR 3/4" SETTER, METER, AND TRANSMITTER	9/10/2024
2.11.6	RETROFIT INSTALL – 1-1/4" SINGLE SERVICE FOR 1" SETTER, METER, AND TRANSMITTER	9/10/2024
2.11.7	RETROFIT INSTALL – 1-1/2" SINGLE SERVICE FOR 1-1/2" SETTER, METER, AND TRANSMITTER	9/10/2024
2.11.8	RETROFIT INSTALL – 2" SINGLE SERVICE FOR 2" SETTER, METER, AND TRANSMITTER	9/10/2024
2.11.9	RETROFIT INSTALL – 1" DUAL SERVICE FOR 3/4" SETTER, METER, AND TRANSMITTER	9/10/2024



DRAWN: \_\_\_\_\_ NT  
CHECKED: \_\_\_\_\_ CLR  
REV: \_\_\_\_\_ SEPT 2024  
REV: \_\_\_\_\_

STANDARD DETAIL

INDEX

INDEX

1.2

SHEET  
NUMBER

SHEET TITLE

REVISION  
DATE

2.11.10	NEW INSTALL – 13”X24” ENCLOSURE – TRAFFIC RATER	
2.11.11	NEW INSTALL – 17”X30” ENCLOSURE – TRAFFIC RATER	
2.11.12	NEW COMMERCIAL INSTALL – 1” DUAL SERVICE FOR ¾” SETTER, METER, AND TRANSMITTER	9/10/2024
2.12.1	SAMPLING STATION	
2.12.2	METER VAULT AND ASSEMBLY 4” TO 10” WATER METER	
2.12.3	SAMPLING PORTS	
2.14.1	THRUST AND ANCHOR BLOCKS	
2.15.1	AIR RELEASE VALVE ASSEMBLY	
2.16.1	ADJUSTABLE PIPE SUPPORT	
2.17.1	TRENCH DETAIL – WATER ONLY	
2.18.1	TRENCH DETAIL – GAS AND WATER	
2.21.1	CROSSING UNDER EXISTING TRANSITE OR SMALL DIAMETER CAST IRON MAINS	
2.21.2	TEST STATION	
2.21.3	WATER MAIN OR LATERAL PARALLEL TO SEWER MAIN	
2.21.4	WATER MAIN CROSSING SEWER MAIN	
2.21.5	WATER MAIN OR LATERAL PARALLEL TO OR CROSSING SEWER SERVICE LATERAL	
2.21.6	WATER SERVICE LATERAL CROSSING SEWER MAIN	

**SECTION 3.0 SEWER DETAILS**

3.1.1	36” MANHOLE
3.3.1	DROP MANHOLE
3.4.1	MANHOLE FRAME AND COVER
3.5.1	TEMPORARY MANHOLE COVER
3.6.1	MANHOLE COLLAR
3.7.1	SEWER PIPE TO MANHOLE CONNECTION
3.8.1	RESILIENT FLEXIBLE CONNECTOR



DRAWN: \_\_\_\_\_ NT  
CHECKED: \_\_\_\_\_ CLR  
REV: \_\_\_\_\_ SEPT 2024  
REV: \_\_\_\_\_

STANDARD DETAIL

INDEX

INDEX

1.3



SHEET  
NUMBER

SHEET TITLE

REVISION  
DATE

3.9.1 SEWER LATERAL

3.10.1 SEWER SADDLE TAP

3.11.1 TRENCH DETAIL– SEWER ONLY

9/13/2024

**SECTION 5.0 PROCESS DETAILS**

5.1.1 FLANGED TEE – FLG X MJ – RESTRAINED

5.1.2 FLANGED TEE – FLG X PUSH ON

5.1.3 GATE VALVE – FLG X MJ – RESTRAINED

5.1.4 GATE VALVE – FLG X PUSH ON

5.1.5 GATE VALVE – MJ X PUSH ON

5.2.1 COUPLING

5.3.1 PROCESS WATER TAPPIN SLEEVES

5.3.2 STANDARD TAP 4” TO 12”

5.3.3 REVERSE TAP 4” TO 12”

5.4.1 REDUCED PRESSURE PRINCIPLE ASSEMBLY, EXTERNAL, HORIZONTAL

5.4.2 AIR GAP SEPARATION

5.5.1 PERMANENT DEAD-END LOCATION FLUSH ASSEMBLY

5.5.2 TEMPORARY DEAD-END FLUSH ASSEMBLY

5.5.3 BLOW-OFF ASSEMBLY

5.5.4 IN-LINE FLUSH ASSEMBLY

5.5.5 FLUSH ASSEMBLY FOR CONSTRUCTION WATER SERVICE

5.6.1 6” NON-POTABLE WATER HYDRANT SERVICE OFF NEW MAINS

5.6.2 HYDRANT SERVICE OFF NEW MAINS

5.6.3 6” NON-POTABLE WATER HYDRANT SERVICE OFF EXISTING MAIN

5.6.4 HYDRANT SERVICE OFF EXISTING MAIN

5.7.1 1” TO 2” SERVICE TAP

5.8.1 RESTRAINED JOINT VERTICAL OFFSET UNDER UTILITY/OBJECT



DRAWN: \_\_\_\_\_ NT  
CHECKED: \_\_\_\_\_ CLR  
REV: \_\_\_\_\_ SEPT 2024  
REV: \_\_\_\_\_

STANDARD DETAIL

INDEX

INDEX

1.4

SHEET  
NUMBER

SHEET TITLE

REVISION  
DATE

5.8.2	RESTRAINED JOINT VERTICAL OFFSET OVER UTILITY/OBJECT	
5.8.3	RESTRAINED JOINT SINGLE VERTICAL OFFSET	
5.9.1	IN-LINE GATE VALVE WITH CONCRETE COLLAR	
5.10.1	NEW COMMERCIAL INSTALL – 1" SINGLE SERVICE FOR 3/4" SETTER, METER, AND TRANSMITTER	9/10/2024
5.10.2	NEW COMMERCIAL INSTALL – 1-1/2" SINGLE SERVICE FOR 1-1/2" SETTER, METER, AND TRANSMITTER	9/10/2024
5.10.3	NEW COMMERCIAL INSTALL – 2" SINGLE SERVICE FOR 2" SETTER, METER, AND TRANSMITTER	9/10/2024
5.10.4	NEW COMMERCIAL INSTALL – 1" DUAL SERVICE FOR 3/4" SETTER, METER, AND TRANSMITTER	9/10/2024
5.10.5	RETROFIT INSTALL – 1" SINGLE SERVICE FOR 3/4" SETTER, METER, AND TRANSMITTER	9/10/2024
5.10.6	RETROFIT INSTALL – 1-1/4" SINGLE SERVICE FOR 1" SETTER, METER, AND TRANSMITTER	9/10/2024
5.10.7	RETROFIT INSTALL – 1-1/2" SINGLE SERVICE FOR 1-1/2" SETTER, METER, AND TRANSMITTER	9/10/2024
5.10.8	RETROFIT INSTALL – 2" SINGLE SERVICE FOR 2" SETTER, METER, AND TRANSMITTER	9/10/2024
5.10.9	RETROFIT INSTALL – 1" DUAL SERVICE FOR 3/4" SETTER, METER, AND TRANSMITTER	9/10/2024
5.10.10	NEW INSTALL – 13"X24" ENCLOSURE – TRAFFIC RATED	
5.10.11	NEW INSTALL – 17"X30" ENCLOSURE – TRAFFIC RATED	
5.10.12	NEW COMMERCIAL INSTALL - 1" DUAL SERVICE FOR 3/4" SETTER, METER, AND TRANSMITTER	9/10/2024
5.12.1	SAMPLING STATION	
5.12.2	METER VAULT AND ASSEMBLY 4" TO 10"	
5.12.3	BACKFLOW PREVENTION ASSEMBLY 4"-10"	
5.13.1	THRUST AND ANCHOR BLOCKS	
5.14.1	AIR RELEASE VALVE ASSEMBLY	
5.15.1	ADJUSTABLE PIPE SUPPORT	
5.16.1	TRENCH DETAIL – PROCESS WATER ONLY	



DRAWN: \_\_\_\_\_ NT  
CHECKED: \_\_\_\_\_ CLR  
REV: \_\_\_\_\_ SEPT 2024  
REV: \_\_\_\_\_

STANDARD DETAIL

INDEX

INDEX

1.5

SHEET  
NUMBER

SHEET TITLE

REVISION  
DATE

5.17.1 TRENCH DETAIL – GAS AND WATER

**SECTION 6.0 LANDSCAPING DETAILS**

6.1A.1 TREE WELL DRIP IRRIGATION

6.1B.1 PARKWAY DRIP IRRIGATION

**SECTION 7.0 PROCESS DETAILS**

7.1.1 TYPICAL UTILITY MAIN LOCATIONS

7.2.1 SIDEWALK CROSS DRAIN

7.3.1 PCC VALLEY GUTTER

7.4.1 CURB OPENING

7.5.1 CONCRETE PAVEMENT PATCH

7.5A.1 CONCRETE PAVEMENT PATCH NOTES

7.6.1 PERMANENT AC PAVEMENT PATCH

7.7.1 TEMPORARY AC PAVEMENT PATCH

7.8.1 TRENCH EXCAVATION/BACKFILL

7.9.1 MONUMENTS

7.10.1 REMOVABLE BOLLARD



DRAWN: \_\_\_\_\_ NT  
CHECKED: \_\_\_\_\_ CLR  
REV: \_\_\_\_\_ SEPT 2024  
REV: \_\_\_\_\_

STANDARD DETAIL

INDEX

INDEX

1.6

NOTES:

1. REFERENCE TRIGID STANDARD DETAIL 2.14 FOR THRUST BLOCK SIZING AND REQUIREMENTS.
2. ALL BOLTS AND EXPOSED METAL SHALL BE COATED WITH BRUSHED-ON MASTIC.
3. TEE, VALVES, FITTINGS, DUCTILE IRON PIPE AND OTHER METAL PARTS SHALL BE ENCASED WITH POLYETHYLENE WRAP PER AWWA C105.
4. CONCRETE FOR PADS SHALL HAVE A COMPRESSIVE STRENGTH OF NOT LESS THAN 3,000 PSI AFTER 28 DAYS. BAG CONCRETE MIX IS NOT ACCEPTABLE.
5. POSITION OF FLG x MJ VALVE (RUN) AND FLG x MJ ADAPTER MAY SWITCH, REFERENCE WATER IMPROVEMENT PLANS.
6. AN ADDITIONAL FLG x MJ VALVE MAY BE REQUIRED IN LIEU OF FLG x MJ ADAPTER, REF. WATER IMPROVEMENT PLANS.

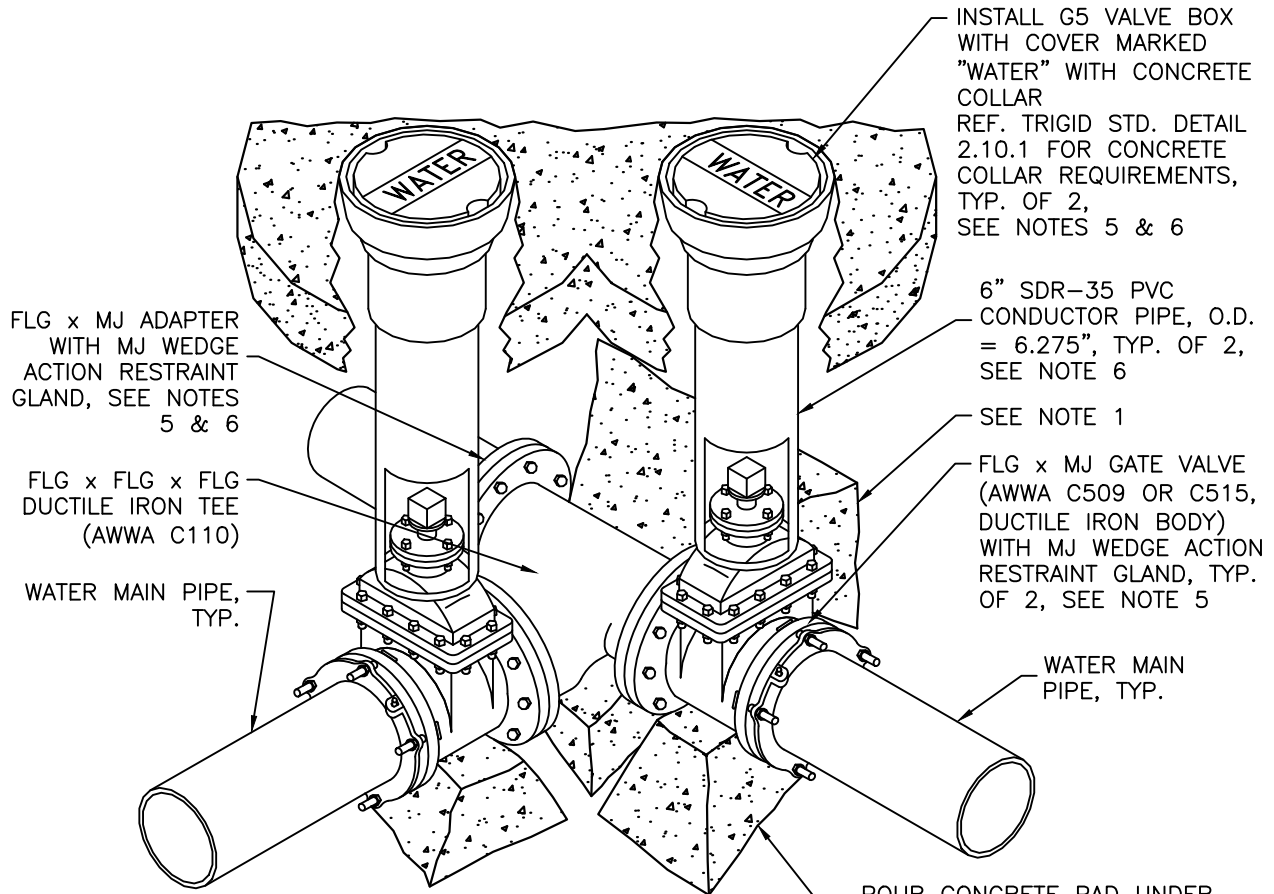

MATERIAL LIST

QTY.	DESCRIPTION
1	FLG x FLG x FLG DUCTILE IRON TEE (AWWA C110)
2	FLG x MJ GATE VALVE WITH DUCTILE IRON BODY (AWWA C509 OR C515)
1	FLG x MJ ADAPTER
3	MJ WEDGE ACTION RESTRAINT GLAND
2	G5 VALVE BOX WITH COVER MARKED "WATER"
2	6" SDR-35 PVC CONDUCTOR PIPE SECTION, O.D. = 6.275"
-	CONCRETE BULK - THRUST BLOCKS, PADS, COLLARS

SOURCE: TMWA DETAIL 10B-2

 <p>440 USA PKWY, SUITE 105 McCARRAN, NEVADA 89437</p>	DRAWN: _____ NT CHECKED: _____ CLR REV: _____ MAY 2024 REV: _____	STANDARD DETAIL  FLANGED TEES FLG x MJ GATE VALVES - RESTRAINED -	WATER   2.1.1

NOTES:

1. REFERENCE TRIGID STANDARD DETAIL 2.14 FOR THRUST BLOCK SIZING AND REQUIREMENTS.
2. ALL BOLTS AND EXPOSED METAL SHALL BE COATED WITH BRUSHED-ON MASTIC.
3. TEE, VALVES, FITTINGS, DUCTILE IRON PIPE AND OTHER METAL PARTS SHALL BE ENCASED WITH POLYETHYLENE WRAP PER AWWA C105.
4. CONCRETE FOR PADS SHALL HAVE A COMPRESSIVE STRENGTH OF NOT LESS THAN 3,000 PSI AFTER 28 DAYS. BAG CONCRETE MIX IS NOT ACCEPTABLE.
5. POSITION OF FLG x PO VALVE (RUN) AND FLG x PO ADAPTER MAY SWITCH, REFERENCE WATER IMPROVEMENT PLANS.
6. AN ADDITIONAL FLG x PO VALVE MAY BE REQUIRED IN LIEU OF FLG x PO ADAPTER, REF. WATER IMPROVEMENT PLANS.

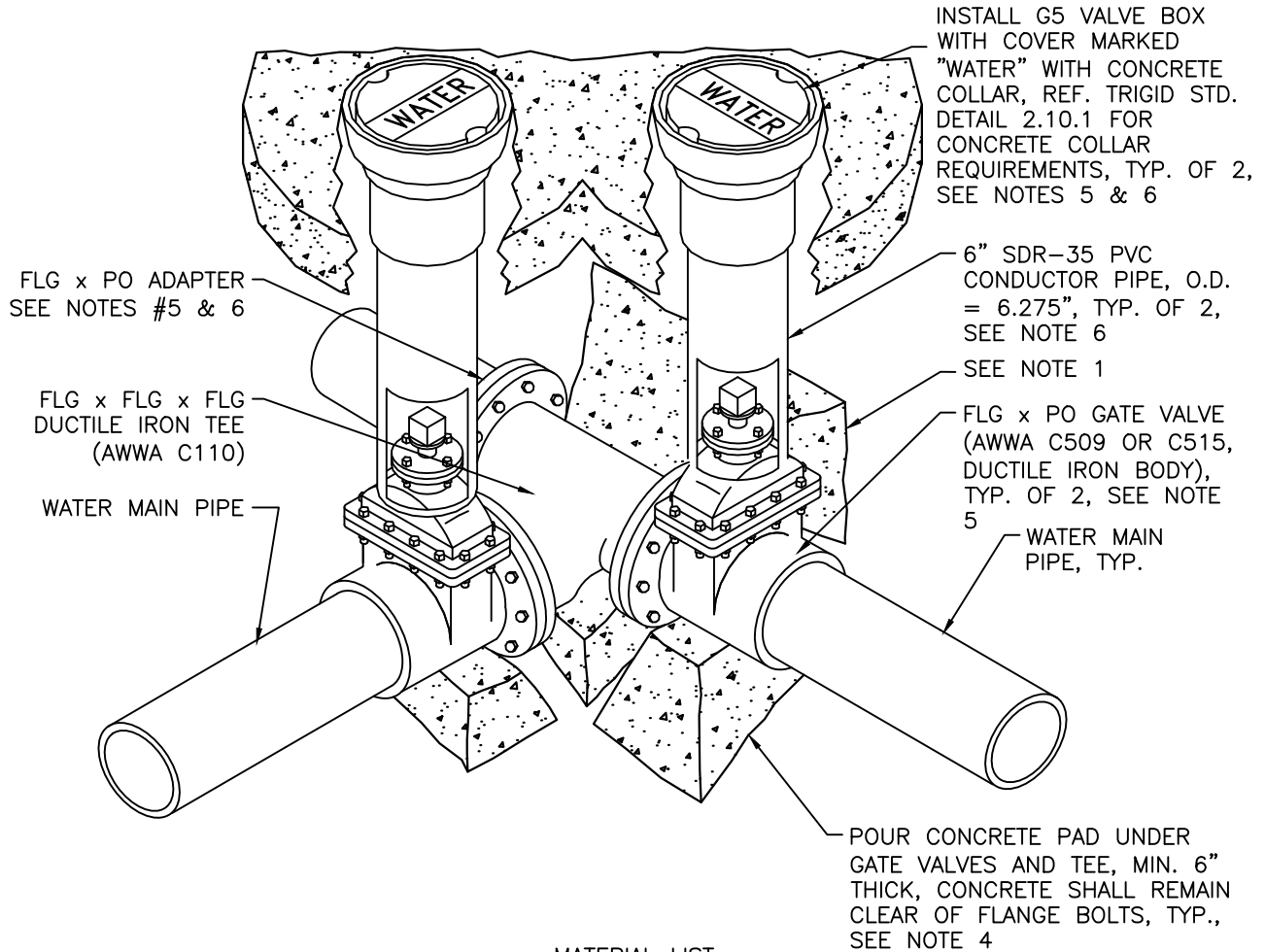

MATERIAL LIST

QTY.	DESCRIPTION
1	FLG x FLG x FLG DUCTILE IRON TEE (AWWA C110)
2	FLG x PO GATE VALVE WITH DUCTILE IRON BODY (AWWA C509 OR C515)
1	FLG x PO ADAPTER
2	G5 VALVE BOX WITH COVER MARKED "WATER"
2	6" SDR-35 PVC CONDUCTOR PIPE SECTION, O.D. = 6.275"
-	CONCRETE BULK - THRUST BLOCKS, PADS, COLLARS

SOURCE: TMWA DETAIL 10B-3

 <p>440 USA PKWY, SUITE 105 McCARRAN, NEVADA 89437</p>	DRAWN: _____ NT CHECKED: _____ CLR REV: _____ MAY 2024 REV: _____	STANDARD DETAIL	WATER
	FLANGED TEES FLG x PO GATE VALVES		2.1.2

NOTES:

1. REFERENCE TRIGID STANDARD DETAIL 2.14 FOR THRUST BLOCK SIZING AND REQUIREMENTS.
2. ALL BOLTS AND EXPOSED METAL SHALL BE COATED WITH BRUSHED-ON MASTIC.
3. TEE, VALVES, FITTINGS, DUCTILE IRON PIPE AND OTHER METAL PARTS SHALL BE ENCASED WITH POLYETHYLENE WRAP PER AWWA C105.
4. CONCRETE FOR PADS SHALL HAVE A COMPRESSIVE STRENGTH OF NOT LESS THAN 3,000 PSI AFTER 28 DAYS. BAG CONCRETE MIX IS NOT ACCEPTABLE.

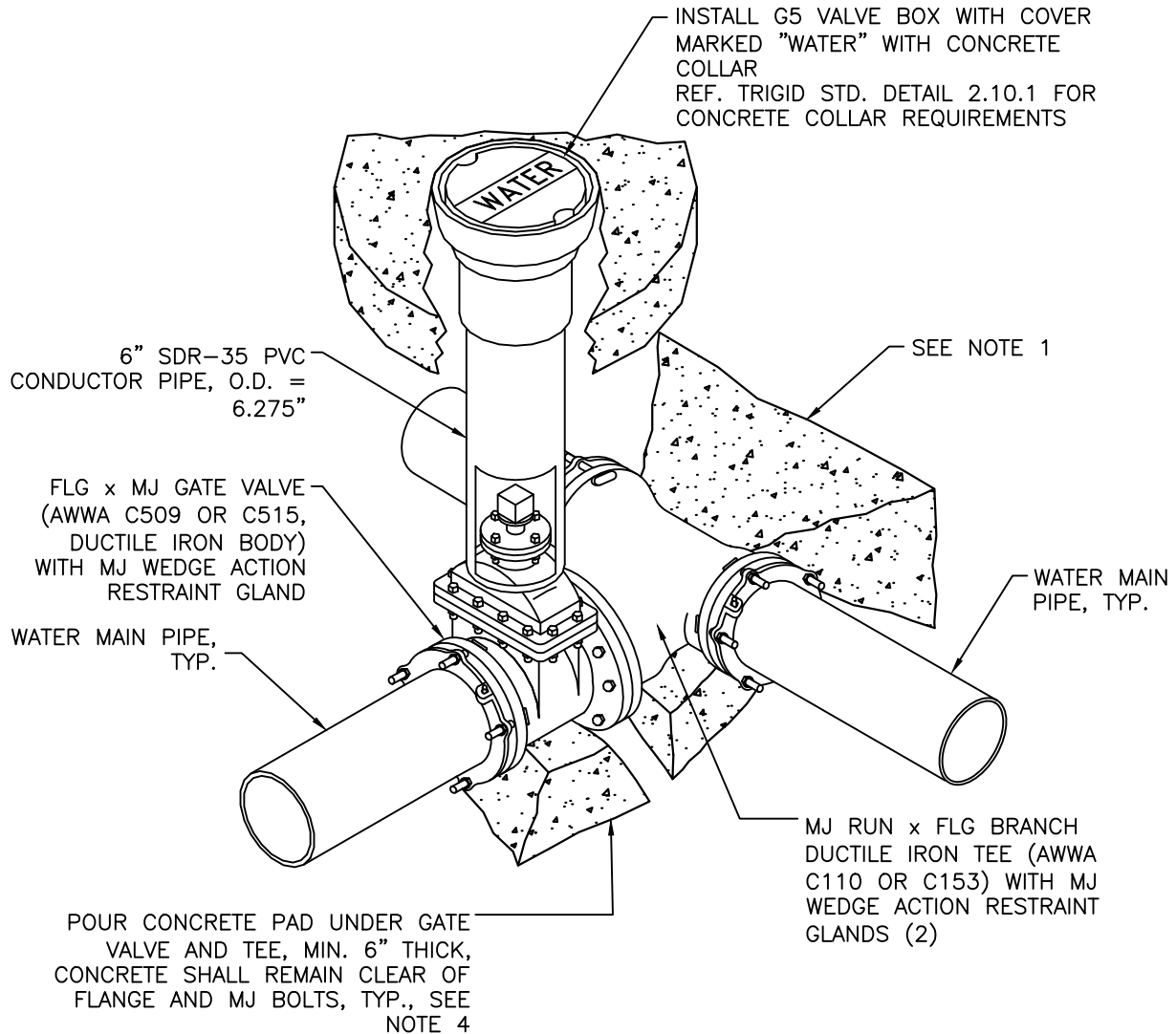

MATERIAL LIST

QTY.	DESCRIPTION
1	MJ RUN x FLG BRANCH DUCTILE IRON TEE (AWWA C110 OR C153)
1	FLG x MJ GATE VALVE WITH DUCTILE IRON BODY (AWWA C509 OR C515)
3	MJ WEDGE ACTION RESTRAINT GLAND
1	G5 VALVE BOX WITH COVER MARKED "WATER"
1	6" SDR-35 PVC CONDUCTOR PIPE SECTION, O.D. = 6.275"
-	CONCRETE BULK - THRUST BLOCKS, PADS, COLLARS

SOURCE: TMWA DETAIL 10B-4

 <p>440 USA PKWY, SUITE 105 McCARRAN, NEVADA 89437</p>	DRAWN: _____ NT CHECKED: _____ CLR REV: _____ MAY 2024 REV: _____	STANDARD DETAIL <b>MECHANICAL JOINT x FLANGED TEES</b> <b>FLG x MJ GATE VALVE</b> - RESTRAINED -	WATER  <b>2.1.3</b>

NOTES:

1. REFERENCE TRIGID STANDARD DETAIL 2.14 FOR THRUST BLOCK SIZING AND REQUIREMENTS.
2. ALL BOLTS AND EXPOSED METAL SHALL BE COATED WITH BRUSHED-ON MASTIC.
3. TEE, VALVES, FITTINGS, DUCTILE IRON PIPE AND OTHER METAL PARTS SHALL BE ENCASED WITH POLYETHYLENE WRAP PER AWWA C105.
4. CONCRETE FOR PADS SHALL HAVE A COMPRESSIVE STRENGTH OF NOT LESS THAN 3,000 PSI AFTER 28 DAYS. BAG CONCRETE MIX IS NOT ACCEPTABLE.

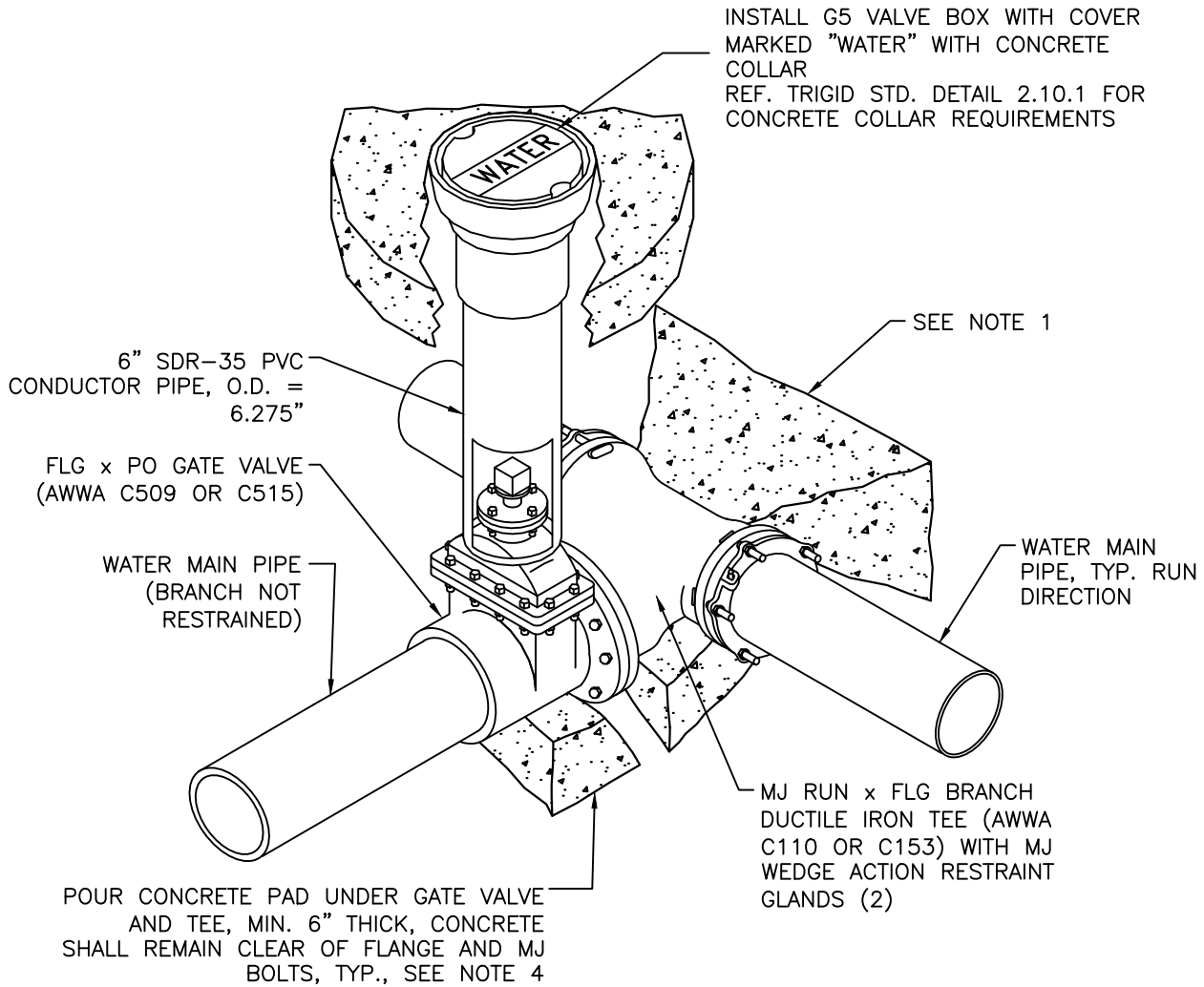

MATERIAL LIST

QTY.	DESCRIPTION
1	MJ RUN x FLG BRANCH DUCTILE IRON TEE (AWWA C110 OR C153)
1	FLG x PO GATE VALVE WITH DUCTILE IRON BODY (AWWA C509 OR C515)
2	MJ WEDGE ACTION RESTRAINT GLAND
1	G5 VALVE BOX WITH COVER MARKED "WATER"
1	6" SDR-35 PVC CONDUCTOR PIPE SECTION, O.D. = 6.275"
-	CONCRETE BULK - THRUST BLOCKS, PADS, COLLARS

SOURCE: TMWA DETAIL 10B-5



DRAWN: \_\_\_\_\_ NT  
 CHECKED: \_\_\_\_\_ CLR  
 REV: \_\_\_\_\_ MAY 2024  
 REV: \_\_\_\_\_

STANDARD DETAIL
<b>MECHANICAL JOINT x FLANGED TEES MJ x PO GATE VALVE</b>

WATER
<b>2.1.4</b>

NOTES:

1. REFERENCE TRIGID STANDARD DETAIL 2.14 FOR THRUST BLOCK SIZING AND REQUIREMENTS.
2. ALL BOLTS AND EXPOSED METAL SHALL BE COATED WITH BRUSHED-ON MASTIC.
3. TEE, VALVES, FITTINGS, DUCTILE IRON PIPE AND OTHER METAL PARTS SHALL BE ENCASED WITH POLYETHYLENE WRAP PER AWWA C105.
4. CONCRETE FOR PADS SHALL HAVE A COMPRESSIVE STRENGTH OF NOT LESS THAN 3,000 PSI AFTER 28 DAYS. BAG CONCRETE MIX IS NOT ACCEPTABLE.

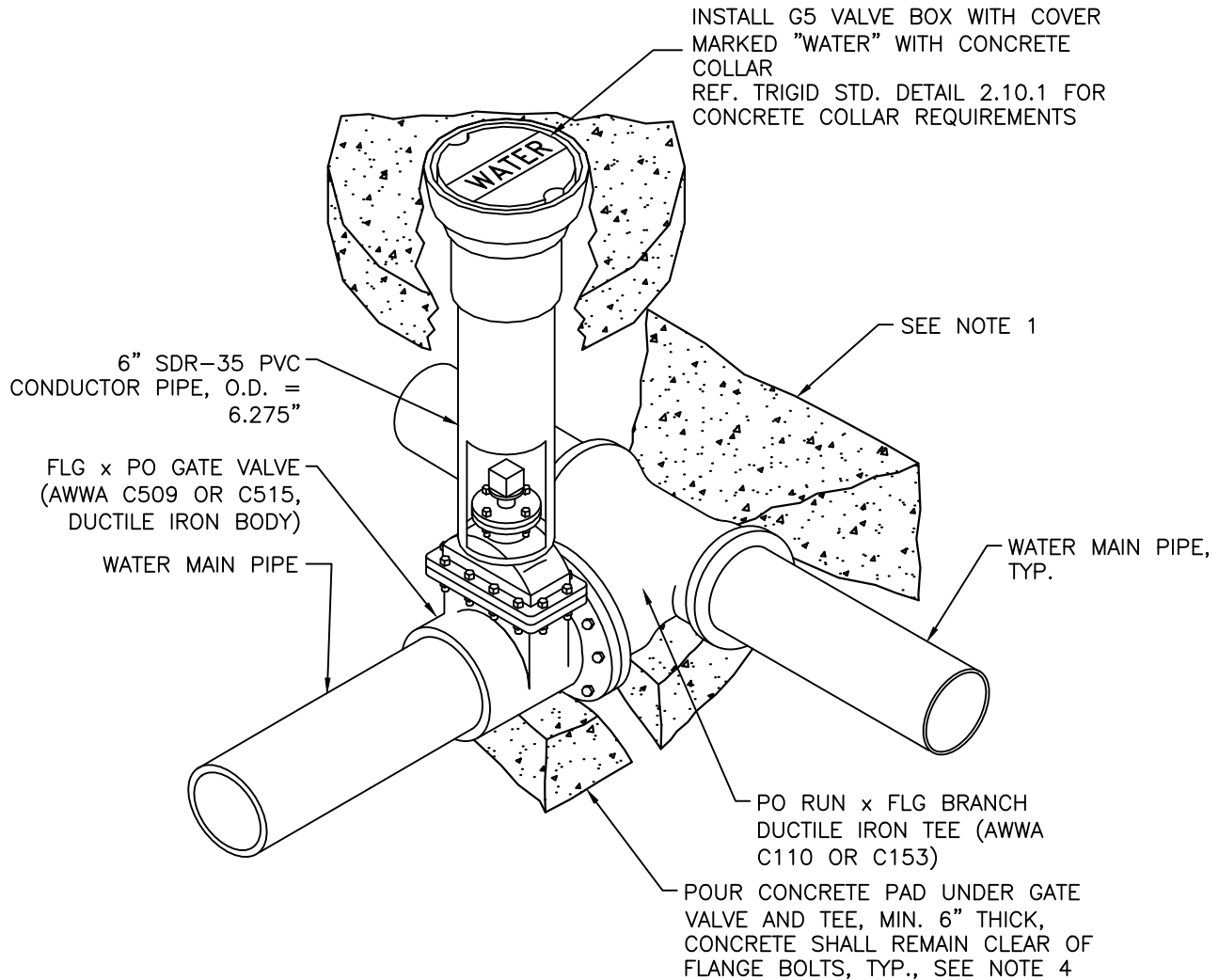

MATERIAL LIST

QTY.	DESCRIPTION
1	PO RUN x FLG BRANCH DUCTILE IRON TEE (AWWA C110 OR C153)
1	FLG x PO GATE VALVE WITH DUCTILE IRON BODY (AWWA C509 OR C515)
1	G5 VALVE BOX WITH COVER MARKED "WATER"
1	6" SDR-35 PVC CONDUCTOR PIPE SECTION, O.D. = 6.275"
-	CONCRETE BULK - THRUST BLOCKS, PADS, COLLARS

SOURCE: TMWA DETAIL 10B-6

 440 USA PKWY, SUITE 105 McCARRAN, NEVADA 89437	DRAWN: _____ NT CHECKED: _____ CLR REV: _____ MAY 2024 REV: _____	STANDARD DETAIL FLANGED TEES FLG x MJ GATE VALVES - RESTRAINED -	WATER  2.1.5



NOTES:

1. COUPLINGS SHALL BE HYMAX 2000 SERIES COUPLINGS AS MANUFACTURED BY TOTAL PIPING SOLUTIONS, INC. OR TRIGID APPROVED EQUIVALENT.
2. SNAP MACHINED END OFF TRANSITE (AC) PIPE TO EXPOSE ROUGH BARREL. INSTALL COUPLING ON ROUGH BARREL SECTION OF TRANSITE PIPE.
3. FIELD MEASURE ACTUAL PIPE O.D. PRIOR TO ORDERING COUPLING. FOR OTHER TYPES OF PIPE NOT LISTED IN THE CHARTS BELOW AND/OR PIPE O.D.'S WHICH MAY DIFFER FROM THOSE LISTED BELOW, CONSULT MANUFACTURER'S SIZING CHART.

TYPE OF PIPE	6" C900 PVC (C900) 6" DUCTILE IRON (DI)		6" TRANSITE (AC) ROUGH BARREL CLASS 100/150/200	
6" C900 PVC (C900) 6" DUCTILE IRON (DI)	HYMAX COUPLING PART NO.	LOW RANGE (C900, DI) 6.42 - 7.05	HYMAX COUPLING PART NO.	HIGH RANGE (AC) 7.01 - 7.68
	2000-0768-260	LOW RANGE (C900, DI) 6.42 - 7.05	2000-0768-260	LOW RANGE (C900, DI) 6.42 - 7.05
6" TRANSITE (AC) ROUGH BARREL CLASS 100/150/200	HYMAX COUPLING PART NO.	LOW RANGE (C900, DI) 6.42 - 7.05	HYMAX COUPLING PART NO.	HIGH RANGE (AC) 7.01 - 7.68
	2000-0768-260	HIGH RANGE (AC) 7.01 - 7.68	2000-0768-260	HIGH RANGE (AC) 7.01 - 7.68

TYPE OF PIPE	8" C900 PVC (C900) 8" DUCTILE IRON (DI)		8" TRANSITE (AC) ROUGH BARREL CLASS 100/150/200	
8" C900 PVC (C900) 8" DUCTILE IRON (DI)	HYMAX COUPLING PART NO.	LOW RANGE (C900, DI) 8.54 - 9.17	HYMAX COUPLING PART NO.	HIGH RANGE (AC) 9.13 - 9.84
	2000-0984-260	LOW RANGE (C900, DI) 8.54 - 9.17	2000-0984-260	LOW RANGE (C900, DI) 8.54 - 9.17
8" TRANSITE (AC) ROUGH BARREL CLASS 100/150/200	HYMAX COUPLING PART NO.	LOW RANGE (C900, DI) 8.54 - 9.17	HYMAX COUPLING PART NO.	HIGH RANGE (AC) 9.13 - 9.84
	2000-0984-260	HIGH RANGE (AC) 9.13 - 9.84	2000-0984-260	HIGH RANGE (AC) 9.13 - 9.84

TYPE OF PIPE	10" C900 PVC (C900) 10" DUCTILE IRON (DI)		10" TRANSITE (AC) ROUGH BARREL CLASS 100/150		10" TRANSITE (AC 200) ROUGH BARREL - CLASS 200	
10" C900 PVC (C900) 10" DUCTILE IRON (DI)	HYMAX COUPLING PART NO.	LOW RANGE (C900, DI) 10.96 - 11.63	HYMAX COUPLING PART NO.	LOW RANGE (AC) 10.96 - 11.63	HYMAX COUPLING PART NO.	HIGH RANGE (AC 200) 11.59 - 12.26
	2000-1226-260	LOW RANGE (C900, DI) 10.96 - 11.63	2000-1226-260	LOW RANGE (C900, DI) 10.96 - 11.63	2000-1226-260	LOW RANGE (C900, DI) 10.96 - 11.63
10" TRANSITE (AC) ROUGH BARREL CLASS 100/150	HYMAX COUPLING PART NO.	LOW RANGE (C900, DI) 10.96 - 11.63	HYMAX COUPLING PART NO.	LOW RANGE (AC) 10.96 - 11.63	HYMAX COUPLING PART NO.	HIGH RANGE (AC 200) 11.59 - 12.26
	2000-1226-260	LOW RANGE (AC) 10.96 - 11.63	2000-1226-260	LOW RANGE (AC) 10.96 - 11.63	2000-1226-260	LOW RANGE (AC) 10.96 - 11.63
10" TRANSITE (AC 200) ROUGH BARREL CLASS 200	HYMAX COUPLING PART NO.	LOW RANGE (C900, DI) 10.96 - 11.63	HYMAX COUPLING PART NO.	LOW RANGE (AC) 10.96 - 11.63	HYMAX COUPLING PART NO.	HIGH RANGE (AC 200) 11.59 - 12.26
	2000-1226-260	HIGH RANGE (AC 200) 11.59 - 12.26	2000-1226-260	HIGH RANGE (AC 200) 11.59 - 12.26	2000-1226-260	HIGH RANGE (AC 200) 11.59 - 12.26

TYPE OF PIPE	12" C900 PVC (C900) 12" DUCTILE IRON (DI)		12" TRANSITE (AC) ROUGH BARREL CLASS 100/150/200	
12" C900 PVC (C900) 12" DUCTILE IRON (DI)	HYMAX COUPLING PART NO.	LOW RANGE (C900, DI) 13.15 - 13.78	HYMAX COUPLING PART NO.	HIGH RANGE (AC) 13.74 - 14.41
	2000-1441-260	LOW RANGE (C900, DI) 13.15 - 13.78	2000-1441-260	LOW RANGE (C900, DI) 13.15 - 13.78
12" TRANSITE (AC) ROUGH BARREL CLASS 100/150/200	HYMAX COUPLING PART NO.	LOW RANGE (C900, DI) 13.15 - 13.78	HYMAX COUPLING PART NO.	HIGH RANGE (AC) 13.74 - 14.41
	2000-1441-260	HIGH RANGE (AC) 13.74 - 14.41	2000-1441-260	HIGH RANGE (AC) 13.74 - 14.41

SOURCE: TWMA DETAIL 10C-2



DRAWN: \_\_\_\_\_ NT  
 CHECKED: \_\_\_\_\_ CLR  
 REV: \_\_\_\_\_ MAY 2024  
 REV: \_\_\_\_\_

STANDARD DETAIL

WATER

COUPLING

2.2.1

TAP SIZE – FLANGED BRANCH							
MAIN SIZE	VENDOR	MAIN TYPE	4"	6"	8"	10"	12"
4"	SM ROM	DI/CI PVC	663-04800400-200 SST-4.90 x 4" FL				
6"	SM ROM	DI/CI PVC	663-06630400-000 SST-7.00 x 4" FL	663*06630600-200 SST-7.00 x 6" FL			
	SM ROM	TR	663-(OD)400-000 SST-(OD) x 4" FL	663-(OD)0600-200 SST-(OD) x 6" FL			
8"	SM ROM	DI/CI PVC	663-09050400-000 SST-9.06 x 4" FL	663-09050600-000 SST-9.06 x 6" FL	663-09050800-200 SST-9.06 x 8" FL		
	SM ROM	TR	663-(OD)0400-000 SST-(OD) x 4" FL	663-(OD)0600-000 SST-(OD) x 6" FL	663-(OD)0800-200 SST-(OD) x 8" FL		
	SM ROM	SCH 40 STEEL	663-08630400-000 SST-8.63 x 4" FL	663-08630600-000 SST-8.63 x 6" FL	663-08630800-200 SST-8.63 x 8" FL		
10"	SM ROM	DI/CI PVC	663-11100400-000 SST-11.45 x 4" FL	663-11100600-000 SST-11.45 x 6" FL	663-11100800-000 SST-11.45 x 8" FL	663-11101000-200 SST-11.45 x 10" FL	
	SM ROM	TR	663-(OD)0400-000 SST-(OD) x 4" FL	663-(OD)0600-000 SST-(OD) x 6" FL	663-(OD)0800-000 SST-(OD) x 8" FL	663-(OD)1000-200 SST-(OD) x 10" FL	
	SM ROM	SCH 40 STEEL	663-10750400-000 SST-11.13 x 4" FL	663-10750600-000 SST-11.13 x 6" FL	663-10750800-000 SST-11.13 x 8" FL	663-10751000-200 SST-11.13 x 10" FL	
12"	SM ROM	DI/CI PVC	663-10750400-000 SST-13.30 x 4" FL	663-13200600-000 SST-13.30 x 6" FL	663-13200800-000 SST-13.30 x 8" FL	663-13201000-000 SST-13.30 x 10" FL	663-13201200-200 SST-13.30 x 12" FL
	SM ROM	TR	663-(OD)0400-000 SST-(OD) x 4" FL	663-(OD)0600-000 SST-(OD) x 6" FL	663-(OD)0800-000004 SST-(OD) x 8" FL	663-(OD)1000-000 SST-(OD) x 10" FL	663-(OD)1200-200 SST-(OD) x 12" FL
	SM ROM	SCH 40 STEEL	663-12750400-000 SST-12.85 x 4" FL	663-12750600-000 SST-12.85 x 6" FL	663-12750800-000 SST-12.85 x 8" FL	663-12751000-000 SST-12.85 x 10" FL	663-12751200-200 SST-12.85 x 12" FL

NOTES:

1. MAXIMUM TEST PRESSURE IS 300 PSI FOR LISTED MANUFACTURERS.
2. FLANGES (FL) SHALL BE STAINLESS STEEL ASTM A 240, TYPE 304.
3. VENDOR (MANUFACTURER): SM = SMITH-BLAIR, ROM = ROMAC INDUSTRIES
4. (OD) = PIPE OUTSIDE DIAMETER. CHECK WITH MANUFACTURER FOR CATALOG NUMBER FOR OTHER SIZES.
5. FOR TAPS ON TRANSITE MAINS OD MUST BE FIELD MEASURED PRIOR TO ORDERING PARTS.

SOURCE: TMWA DETAIL 10D-2



DRAWN: \_\_\_\_\_ NT  
 CHECKED: \_\_\_\_\_ CLR  
 REV: \_\_\_\_\_ MAY 2024  
 REV: \_\_\_\_\_

STANDARD DETAIL
<b>WATER TAPPING SLEEVES</b>

WATER
<b>2.3.1</b>

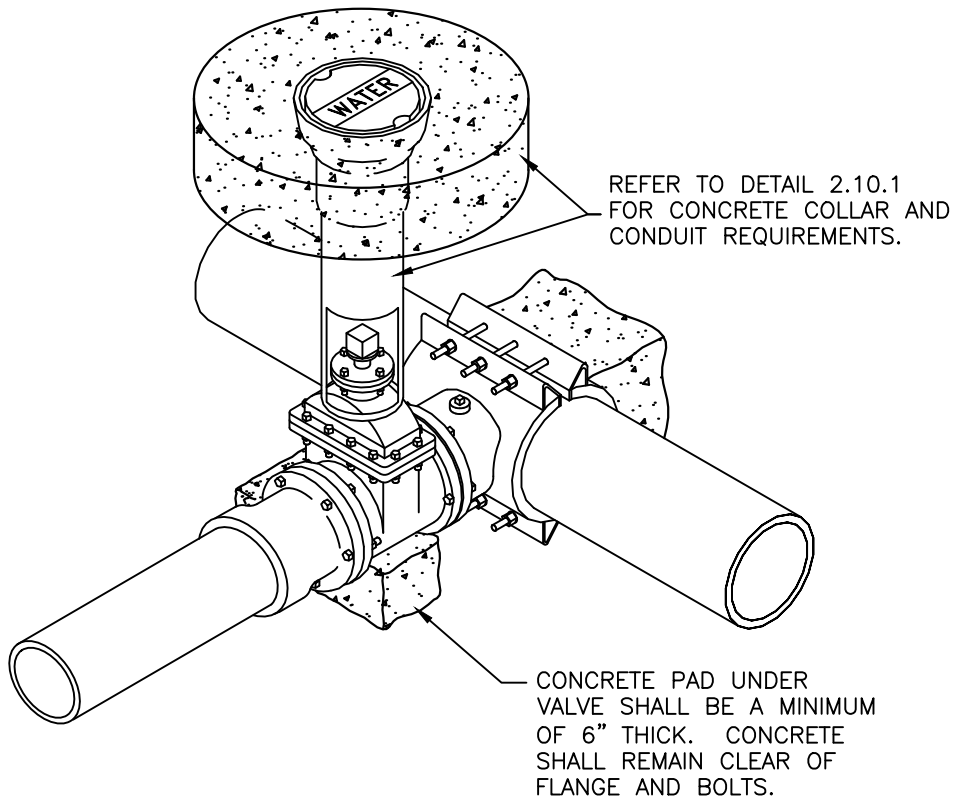

NOTES:

1. REQUIRES ONE (1) TAPPING SLEEVE. REFER TO 2.3.1.
2. WHEN TAPPING STEEL OR OD STEEL BACKING PLATE MUST BE DESIGNED BY ENGINEER. WHEN TAPPING OD STEEL SIZE ON SIZE, REDUCE TAP ONE SIZE THEN BELL UP AFTER TAP.
3. REFER TO DETAIL 2.14 FOR THRUST BLOCK SIZING. BAG CONCRETE IS NOT ACCEPTABLE FOR PAD OR THRUST BLOCK. CONCRETE SHALL HAVE A MINIMUM 28 DAY COMPRESSIVE STRENGTH OF 3,000 PSI.
4. ALL EXPOSED METAL MUST BE COATED WITH BRUSH ON MASTIC.
5. REMOVE TEST PLUG AND HYDROSTATICALLY PRESSURE TEST TAPPING SLEEVE NOT TO EXCEED MANUFACTURER'S PRESSURE RATING, APPLY PIPE COMPOUND, AND REINSERT PLUG.
6. VALVE SHALL BE BLIND FLANGED AND PRESSURE TESTED AT TIME OF TAPPING SLEEVE PRESSURE TEST.
7. TAP SHALL BE A MINIMUM OF 24" FROM THE CUT OR SPIGOT END OF THE PIPE OR THE PIPE TO BELL TRANSITION.

MATERIAL LIST

QTY	DESCRIPTION
1	FL x FL RESILIENT WEDGE GATE VALVE WITH 2" OPERATING NUT (SIZE TO MATCH TAP DIAMETER)
1	TAPPING SLEEVE (STAINLESS STEEL FLANGE)
1	FL x PO ADAPTER
1	6" $\phi$ SDR-35 PVC CONDUIT PIPE SECTION
1	G5 VALVE BOX WITH COVER MARKED "WATER"
1	FULL FACE GASKET
1	CONCRETE BULK
1	MASTIC (1 GALLON CAN - BRUSH ON)

SOURCE: TMWA DETAIL 10D-3



DRAWN: \_\_\_\_\_ NT  
 CHECKED: \_\_\_\_\_ CLR  
 REV: \_\_\_\_\_ MAY 2024  
 REV: \_\_\_\_\_

STANDARD DETAIL

STANDARD TAP 4"-12"

WATER

2.3.2

NOTES:

1. REQUIRES ONE (1) TAPPING SLEEVE. REFER TO 2.3.1.
2. WHEN TAPPING STEEL OR OD STEEL BACKING PLATE MUST BE DESIGNED BY ENGINEER. WHEN TAPPING OD STEEL SIZE ON SIZE, REDUCE TAP ONE SIZE THEN BELL UP AFTER TAP.
3. REFER TO DETAIL 2.14 FOR THRUST BLOCK SIZING AND CONCRETE REQUIREMENTS. BAG CONCRETE IS NOT ACCEPTABLE FOR PAD OR THRUST BLOCK. USE THRUST BLOCK SIZING FOR DEAD END CONDITION FOR 90 DEGREE ELBOWS.
4. ALL EXPOSED METAL MUST BE COATED WITH BRUSH ON MASTIC.
5. REMOVE TEST PLUG AND HYDROSTATICALLY PRESSURE TEST TAPPING SLEEVE NOT TO EXCEED MANUFACTURER'S PRESSURE RATING, APPLY PIPE COMPOUND, AND REINSERT PLUG.
6. VALVE SHALL BE BLIND FLANGED AND PRESSURE TESTED AT TIME OF TAPPING SLEEVE PRESSURE TEST.
7. TAP SHALL BE A MINIMUM OF 24" FROM THE CUTOR SPIGOT END OF THE PIPE OR THE PIPE TO BELL TRANSITION.

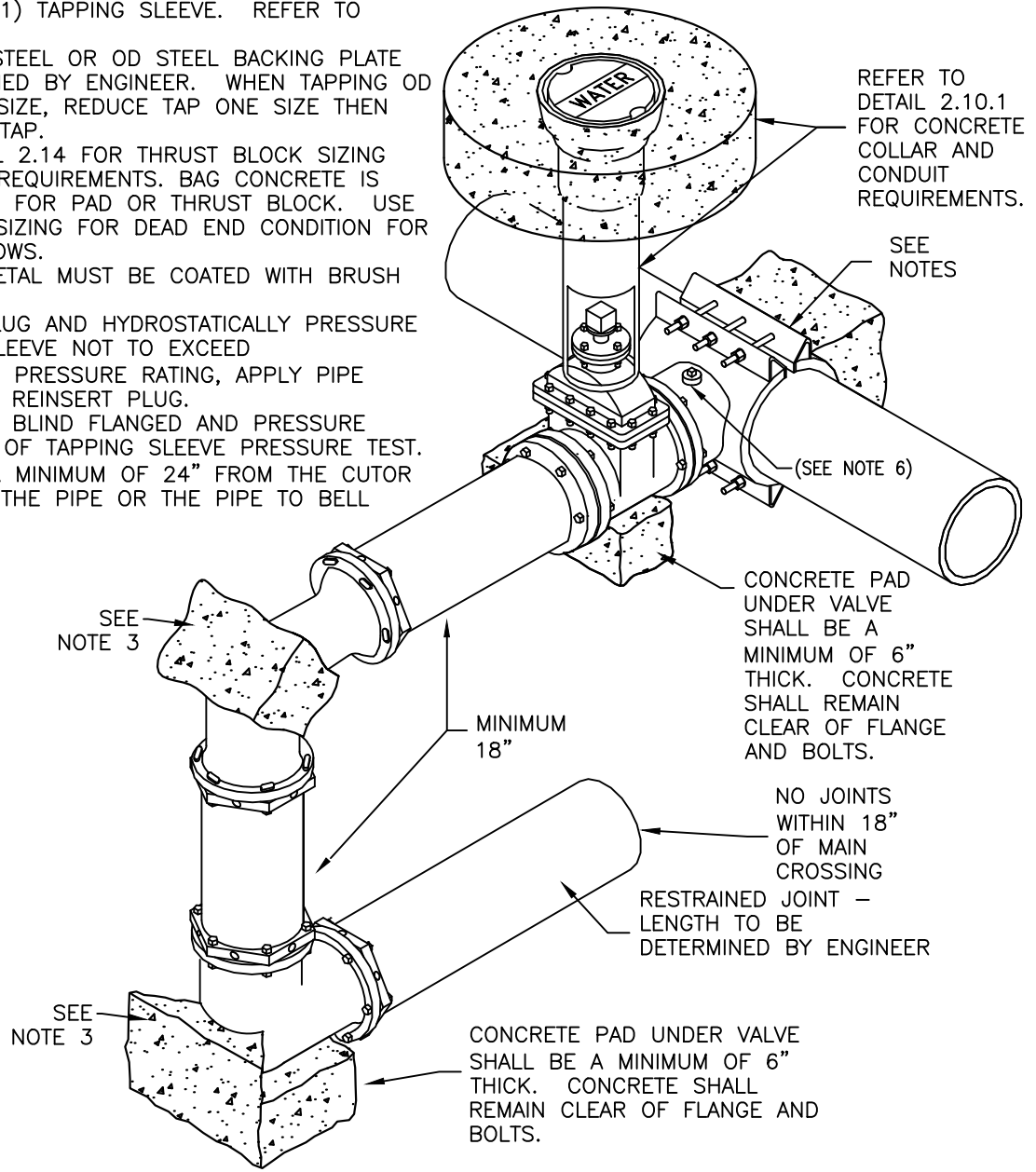

MATERIAL LIST

QTY	DESCRIPTION
1	TAPPING SLEEVE (STAINLESS STEEL FLANGE)
1	FL x FL RESILIENT WEDGE GATE VALVE WITH 2" OPERATING NUT (SIZE TO MATCH TAP DIAMETER)
1	6" $\phi$ SDR-35 PVC CONDUIT PIPE
1	G5 VALVE BOX WITH COVER MARKED "WATER"
1	FL x MJ ADAPTER - RESTRAINED
1	CONCRETE BULK
1	MASTIC (1 GALLON CAN - BRUSH ON)
2	90° MJ x MJ ELBOW, DUCTILE IRON - RESTRAINED
1	CONCRETE BULK
2	PE x PE DUCTILE IRON PIPE MINIMUM 18"

SOURCE: TMWA DETAIL 10D-4

 440 USA PKWY, SUITE 105 McCARRAN, NEVADA 89437	DRAWN: _____ NT CHECKED: _____ CLR REV: _____ MAY 2024 REV: _____	STANDARD DETAIL  <b>REVERSE TAP 4"-12"</b>	WATER  <b>2.3.3</b>

PLAN VIEW

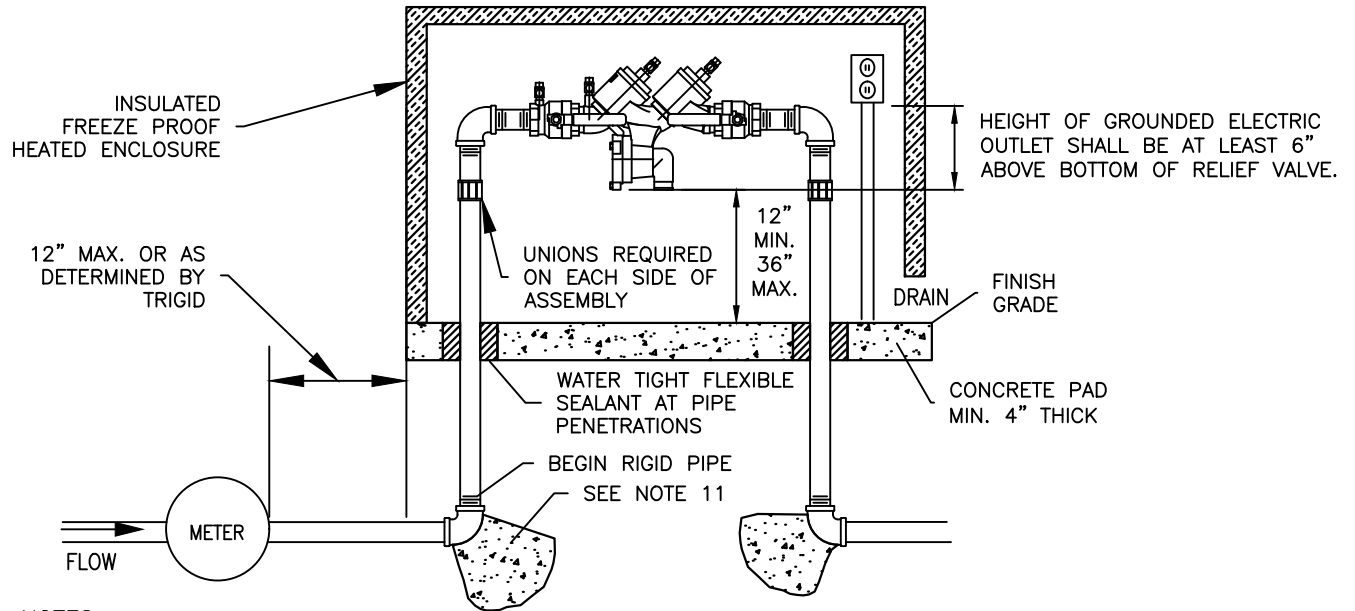
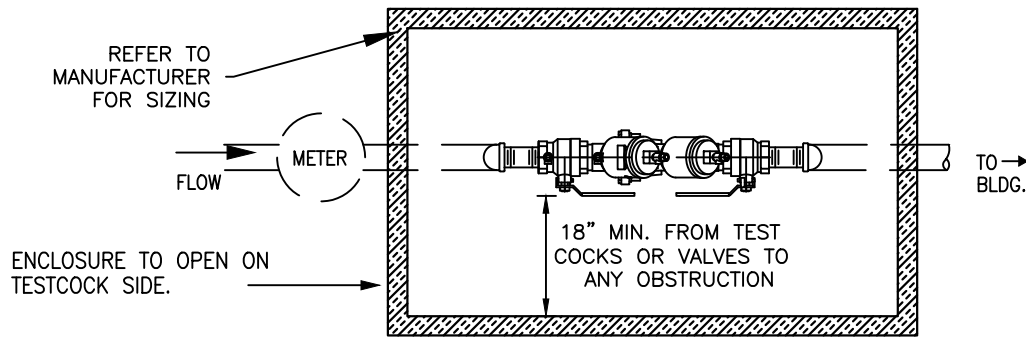

NOTES:

1. ASSEMBLY SHALL BE A USC APPROVED LEAD FREE DEVICE.
2. THE RP SHALL BE INSTALLED ABOVE GRADE.
3. GROUNDED ELECTRIC SUPPLY SHALL BE A MINIMUM OF 6" ABOVE BOTTOM OF RELIEF VALVE AND STUBBED TO THE OUTSIDE.
4. NO STOP AND WASTE VALVES.
5. FREEZE PROOF INSULATED BOX AND 1 SOURCE OF HEAT ARE REQUIRED. 2 SOURCES OF HEAT ARE STRONGLY RECOMMENDED.
6. INSULATED BOX SHALL SWING CLEAR OF ASSEMBLY TO PROVIDE CLEARANCES SHOWN OR INSULATED BOX SHALL BE SIZED TO PROVIDE CLEARANCES SHOWN.
7. SPRING LOADED LID REQUIRED ON LARGE BOXES.
8. THERMAL EXPANSION PROTECTION IS REQUIRED IN ANY DOMESTIC WATER SUPPLY SYSTEM THAT IS DOWNSTREAM FROM A BACKFLOW PREVENTION DEVICE. REFERENCE: UNIFORM PLUMBING CODE & NAC 445A.67235.
9. INSPECTION BY TRIGID PERSONNEL REQUIRED BEFORE METER IS SET OR SERVICE IS ACTIVATED.
10. IF INITIAL TEST DONE BY TRIGID FIELD PERSONNEL FAILS, RETESTING OF BACKFLOW ASSEMBLY IS REQUIRED WITHIN 7 DAYS AFTER METER IS SET OR SERVICE ACTIVATION. COPY OF TEST RESULTS TO BE FORWARDED TO TRIGID BY A CERTIFIED ASSEMBLY TESTER WITHIN THAT SAME TIMEFRAME.
11. MINIMUM DIMENSIONS FOR THE THRUST BLOCK BEARING AREA FOR PIPE 2" AND SMALLER SHALL BE 8" X 8" AND 12" IN DEPTH. ALL OTHER SIZES TO BE DETERMINED BY ENGINEER.

SOURCE: TMWA DETAIL 10A-2



DRAWN: \_\_\_\_\_ NT  
 CHECKED: \_\_\_\_\_ CLR  
 REV: \_\_\_\_\_ MAY 2024  
 REV: \_\_\_\_\_

STANDARD DETAIL

REDUCED PRESSURE PRINCIPLE  
 ASSEMBLY FOR DOMESTIC USE  
 EXTERNAL - HORIZONTAL

WATER

2.4.1

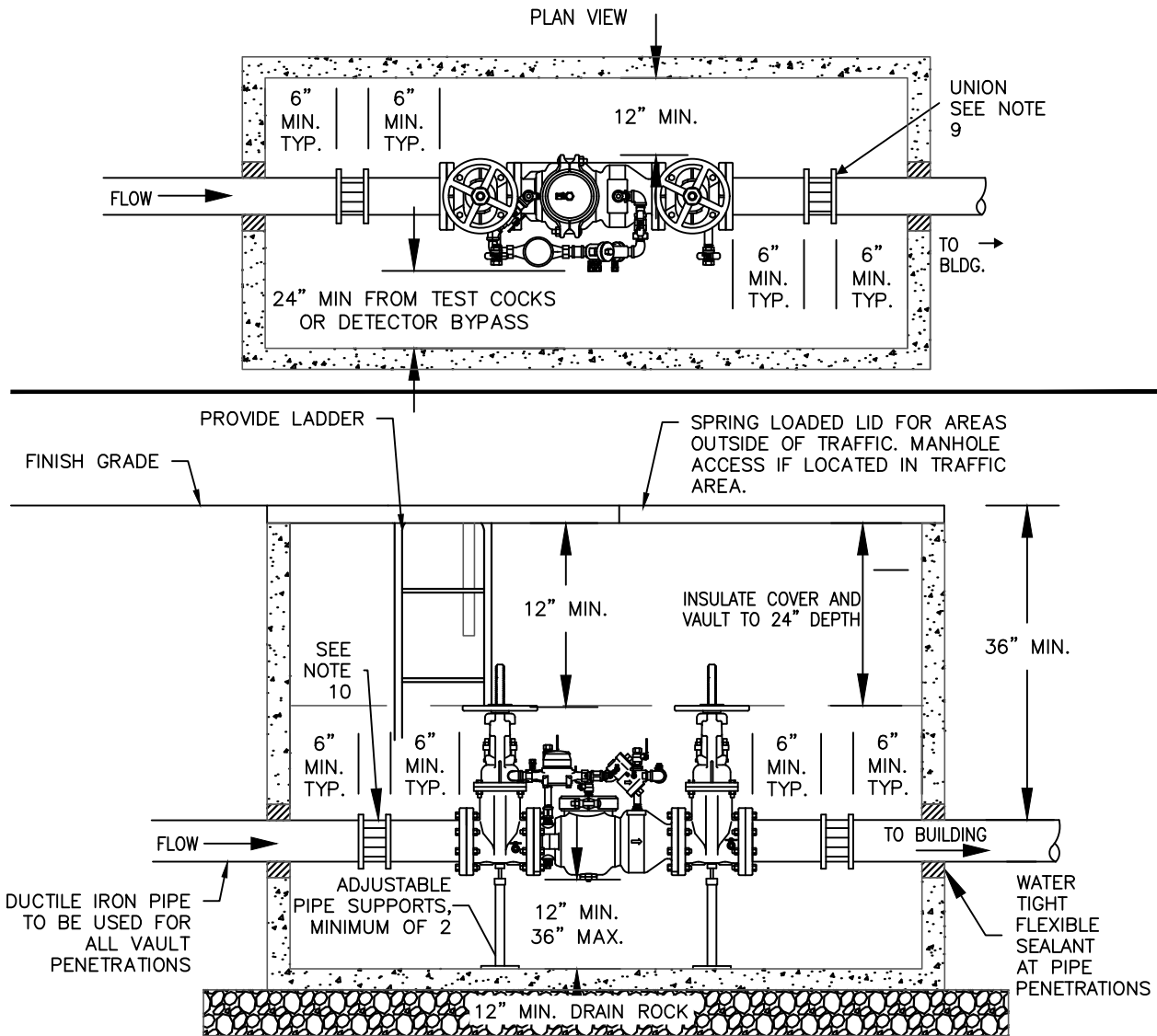

NOTES:

1. ASSEMBLY SHALL BE A USC APPROVED LEAD FREE DEVICE.
2. FREEZE PROOF INSULATED VAULT REQUIRED.
3. BELOW GROUND VAULT SHALL BE SIZED TO PROVIDE CLEARANCES AS SHOWN ABOVE.
4. BELOW GROUND VAULT SHALL REMAIN DRY THROUGHOUT THE YEAR, CONTRACTOR SHALL ENSURE THERE IS PROPER DRAINAGE AROUND THE VAULT
5. SPRING LOADED LID REQUIRED ON LARGE VAULTS WITH ASSEMBLIES LARGER THAN 2 INCHES. MANHOLE ACCESS IS REQUIRED IN AREAS SUBJECT TO VEHICULAR TRAFFIC.
6. NO STOP AND WASTE VALVES.
7. BACKFLOW INSPECTION BY TRIGID PERSONNEL REQUIRED BEFORE METER IS SET OR SERVICE IS ACTIVATED.
8. TESTING OF THE ASSEMBLY REQUIRED WITHIN 7 DAYS AFTER METER IS SET OR SERVICE ACTIVATION. COPY OF TEST RESULTS TO BE FORWARDED TO TRIGID BY A CERTIFIED ASSEMBLY TESTER WITHIN THAT SAME TIMEFRAME.
9. UNIONS TO BE INSTALLED WITH ALL ASSEMBLIES ON BOTH SIDES OF ASSEMBLY.
10. VALVES ON DETECTOR BYPASS SHALL REMAIN OPEN AT ALL TIMES.

SOURCE: TMWA DETAIL 10A-5

 <p>440 USA PKWY, SUITE 105 McCARRAN, NEVADA 89437</p>	DRAWN: _____ NT CHECKED: _____ CLR REV: _____ MAY 2024 REV: _____	STANDARD DETAIL	WATER
	<b>FIRE - CLASS 1, 2, &amp; 3, DOUBLE CHECK VALVE DETECTOR ASSEMBLY, EXTERNAL, HORIZONTAL, BELOW GRADE</b>		<b>2.4.2</b>

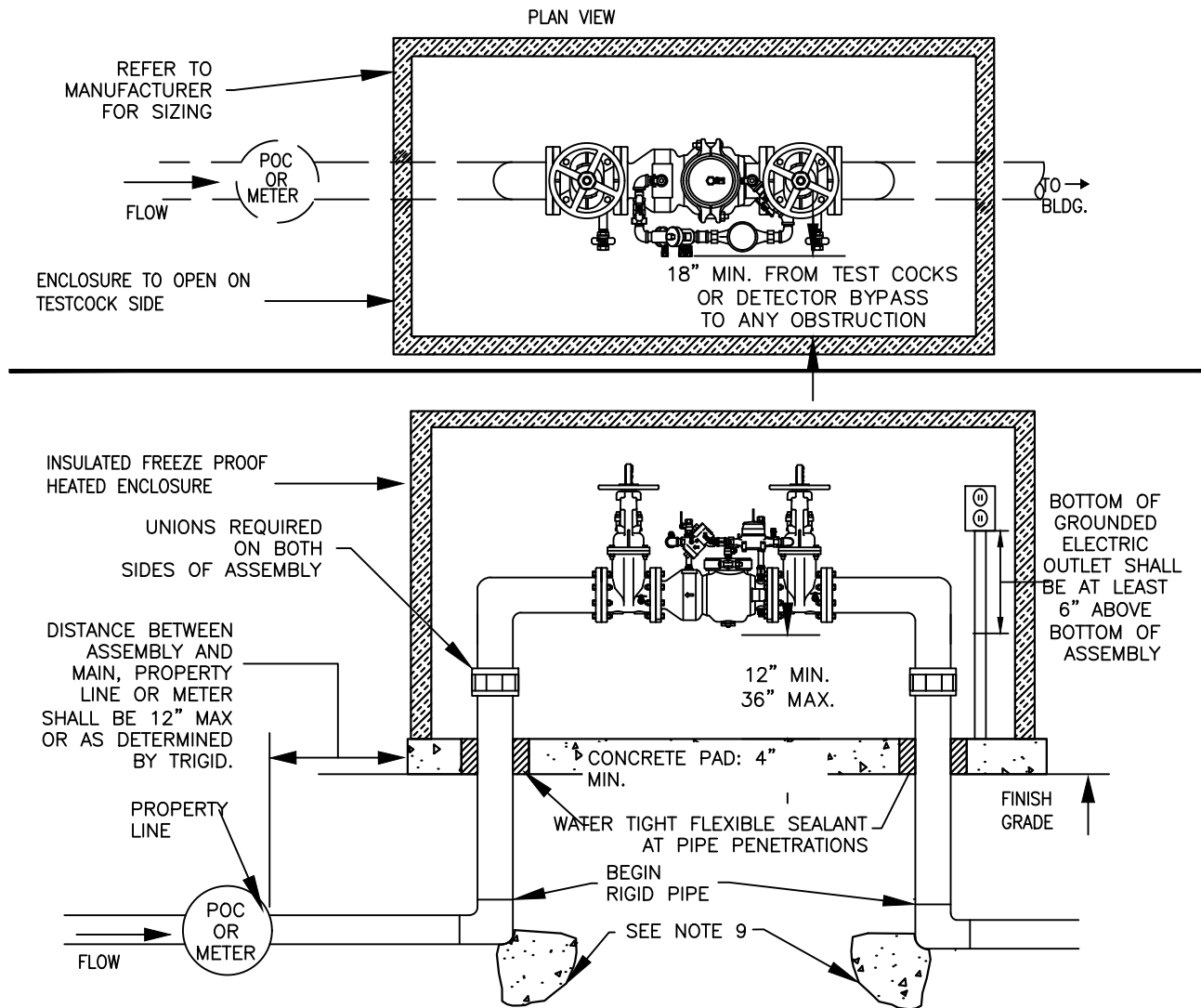

NOTES:

1. ASSEMBLY SHALL BE A USC APPROVED LEAD FREE DEVICE.
2. GROUNDED ELECTRIC SUPPLY SHALL BE A MINIMUM OF 6" ABOVE BOTTOM OF RELIEF VALVE AND STUBBED TO THE OUTSIDE.
3. FREEZE PROOF INSULATED BOX AND 1 SOURCE OF HEAT ARE REQUIRED. 2 SOURCES OF HEAT ARE STRONGLY RECOMMENDED.
4. INSULATED BOX SHALL SWING CLEAR OF ASSEMBLY TO PROVIDE CLEARANCES SHOWN IN PLAN VIEW OR INSULATED BOX SHALL BE SIZED TO PROVIDE CLEARANCES
5. NO STOP AND WASTE VALVES.
6. CALL LOCAL BUILDING AND/OR FIRE DEPARTMENT FOR DEPTH AND TYPE OF PIPE TO BE USED.
7. INSPECTION BY TRIGID PERSONNEL REQUIRED BEFORE METER IS SET OR SERVICE IS ACTIVATED.
8. TESTING OF BACKFLOW ASSEMBLY REQUIRED WITHIN 7 DAYS AFTER METER IS SET OR SERVICE ACTIVATION. COPY OF TEST RESULTS TO BE FORWARDED TO TRIGID PERSONNEL BY A CERTIFIED ASSEMBLY TESTER WITHIN THAT SAME TIMEFRAME.
9. MINIMUM DIMENSIONS FOR THE THRUST BLOCK BEARING AREA FOR PIPE 2" AND SMALLER SHALL BE 8" X 8" AND 12" IN DEPTH. ALL OTHER SIZES TO BE DETERMINED BY TRIGID ENGINEER.
10. UNIONS TO BE INSTALLED WITH ALL ASSEMBLIES ON BOTH SIDES OF ASSEMBLY.
11. VALVES ON DETECTOR BYPASS SHALL REMAIN OPEN AT ALL TIMES.

SOURCE: TMWA DETAIL 10A-6

 <p>440 USA PKWY, SUITE 105 McCARRAN, NEVADA 89437</p>	DRAWN: _____ NT CHECKED: _____ CLR REV: _____ MAY 2024 REV: _____	STANDARD DETAIL <b>FIRE - CLASS 1, 2, &amp; 3, DOUBLE CHECK          VALVE DETECTOR ASSEMBLY,          EXTERNAL, HORIZONTAL, ABOVE GRADE</b>	WATER  <b>2.4.3</b>



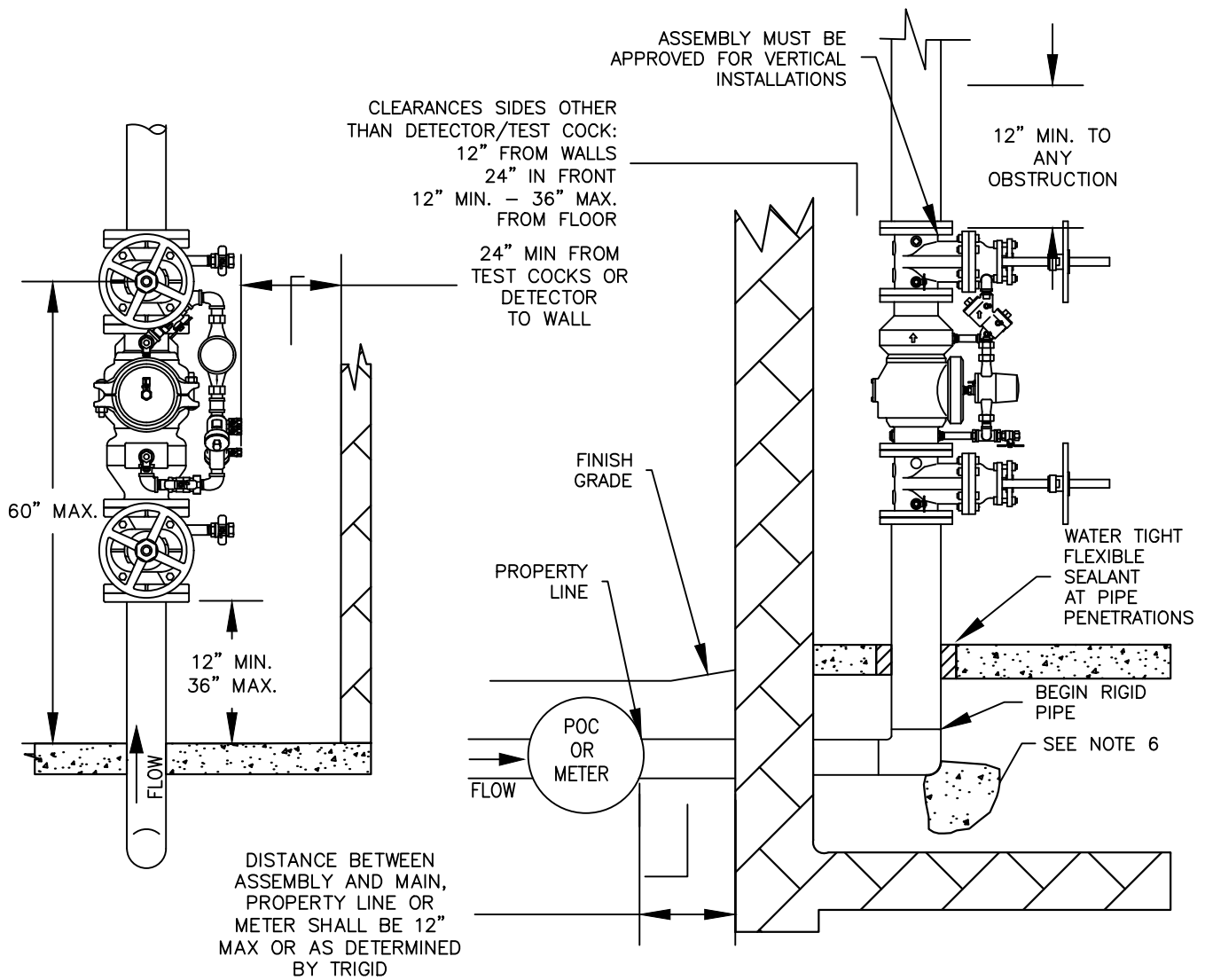

NOTES:

1. ASSEMBLY SHALL BE A USC APPROVED DEVICE.
2. NO STOP AND WASTE VALVES.
3. CALL LOCAL BUILDING AND/OR FIRE DEPARTMENTS FOR DEPTH AND TYPE OF PIPE TO BE USED.
4. INSPECTION BY TRIGID PERSONNEL REQUIRED BEFORE METER IS SET OR SERVICE IS ACTIVATED.
5. TESTING OF BACKFLOW ASSEMBLY REQUIRED WITHIN 7 DAYS AFTER METER IS SET OR SERVICE ACTIVATION. COPY OF TEST RESULTS TO BE FORWARDED TO TRIGID PERSONNEL BY A CERTIFIED ASSEMBLY TESTER WITHIN THAT SAME TIMEFRAME.
6. MINIMUM DIMENSIONS FOR THE THRUST BLOCK BEARING AREA FOR PIPE 2" AND SMALLER SHALL BE 8" X 8" AND 12" IN DEPTH. ALL OTHER SIZES TO BE DETERMINED BY TRIGID ENGINEER.
7. TRIGID MUST APPROVE THE USE OF INTERNAL BACKFLOW ASSEMBLIES.
8. VALVES ON DETECTOR BYPASS SHALL REMAIN OPEN AT ALL TIMES.

SOURCE: TMWA DETAIL 10A-7



DRAWN: \_\_\_\_\_ NT  
 CHECKED: \_\_\_\_\_ CLR  
 REV: \_\_\_\_\_ MAY 2024  
 REV: \_\_\_\_\_

STANDARD DETAIL  
 FIRE - CLASS 1, 2, & 3, DOUBLE CHECK  
 VALVE DETECTOR ASSEMBLY,  
 INTERNAL, VERTICAL

WATER

2.4.4



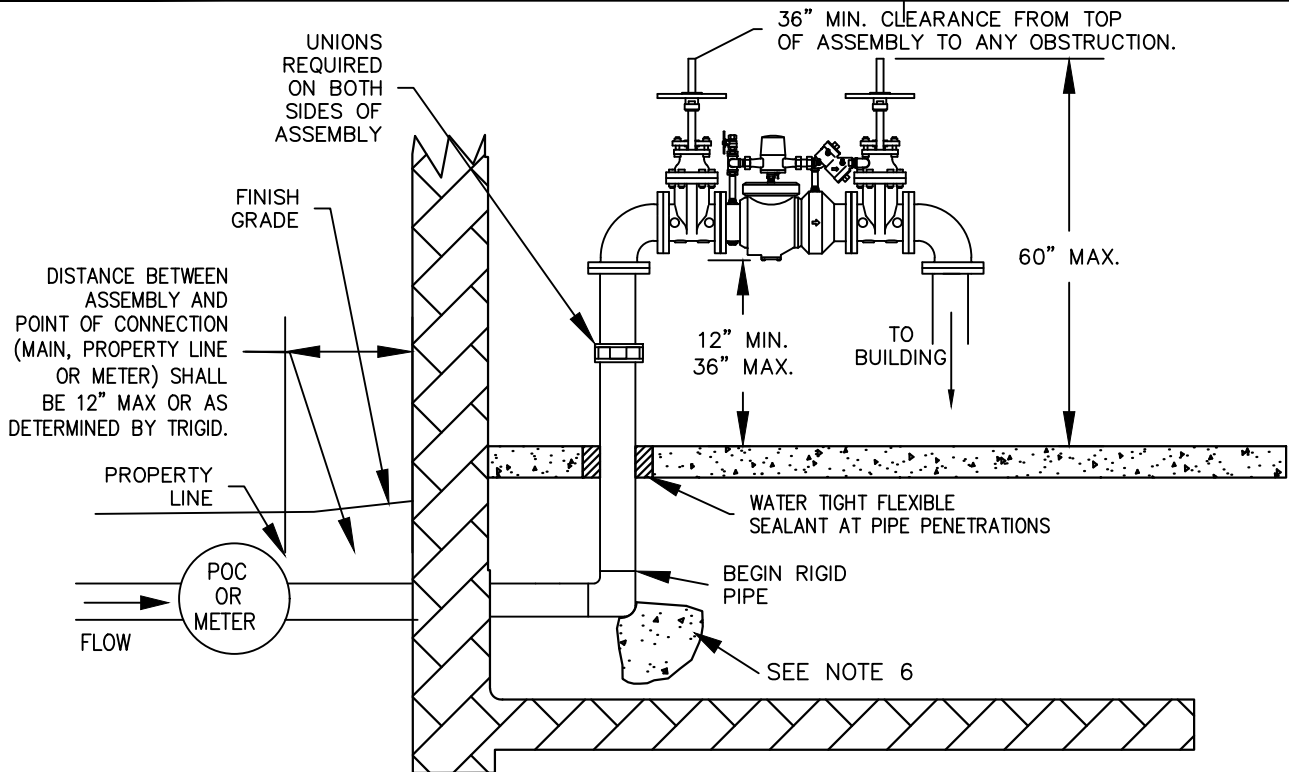
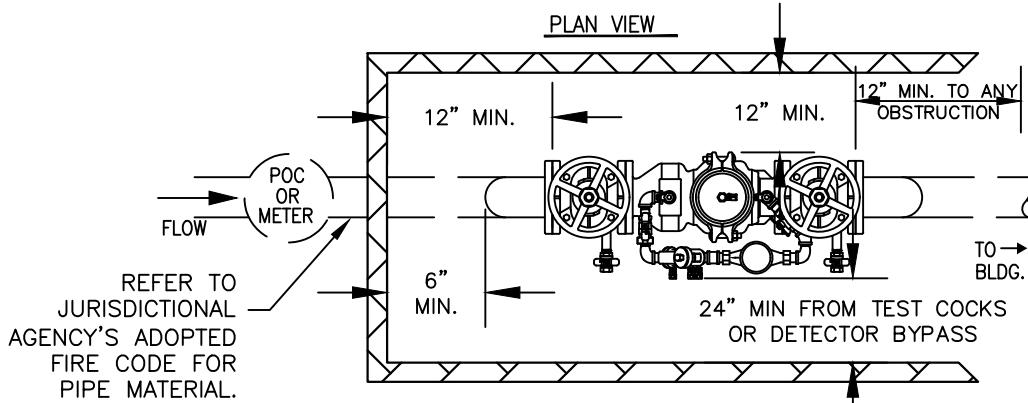

NOTES:

1. ASSEMBLY SHALL BE A USC APPROVED DEVICE.
2. NO STOP AND WASTE VALVES.
3. CALL LOCAL BUILDING AND/OR FIRE DEPARTMENTS FOR DEPTH AND TYPE OF PIPE TO BE USED.
4. INSPECTION BY TRIGID PERSONNEL REQUIRED BEFORE METER IS SET OR SERVICE IS ACTIVATED.
5. TESTING OF BACKFLOW ASSEMBLY REQUIRED WITHIN 7 DAYS AFTER METER IS SET OR SERVICE ACTIVATION. COPY OF TEST RESULTS TO BE FORWARDED TO TRIGID PERSONNEL BY A CERTIFIED ASSEMBLY TESTER WITHIN THAT SAME TIMEFRAME.
6. MINIMUM DIMENSIONS FOR THE THRUST BLOCK BEARING AREA FOR PIPE 2" AND SMALLER SHALL BE 8" X 8" AND 12" IN DEPTH. ALL OTHER SIZES TO BE DETERMINED BY ENGINEER.
7. VALVES ON DETECTOR BYPASS SHALL REMAIN OPEN AT ALL TIMES.
8. TRIGID MUST APPROVE THE USE OF INTERNAL BACKFLOW ASSEMBLIES.

SOURCE: TMWA DETAIL 10A-8



DRAWN: \_\_\_\_\_ NT  
 CHECKED: \_\_\_\_\_ CLR  
 REV: \_\_\_\_\_ MAY 2024  
 REV: \_\_\_\_\_

STANDARD DETAIL

FIRE - CLASS 1, 2, & 3, DOUBLE CHECK  
 VALVE DETECTOR ASSEMBLY, INTERNAL,  
 HORIZONTAL

WATER

2.4.5

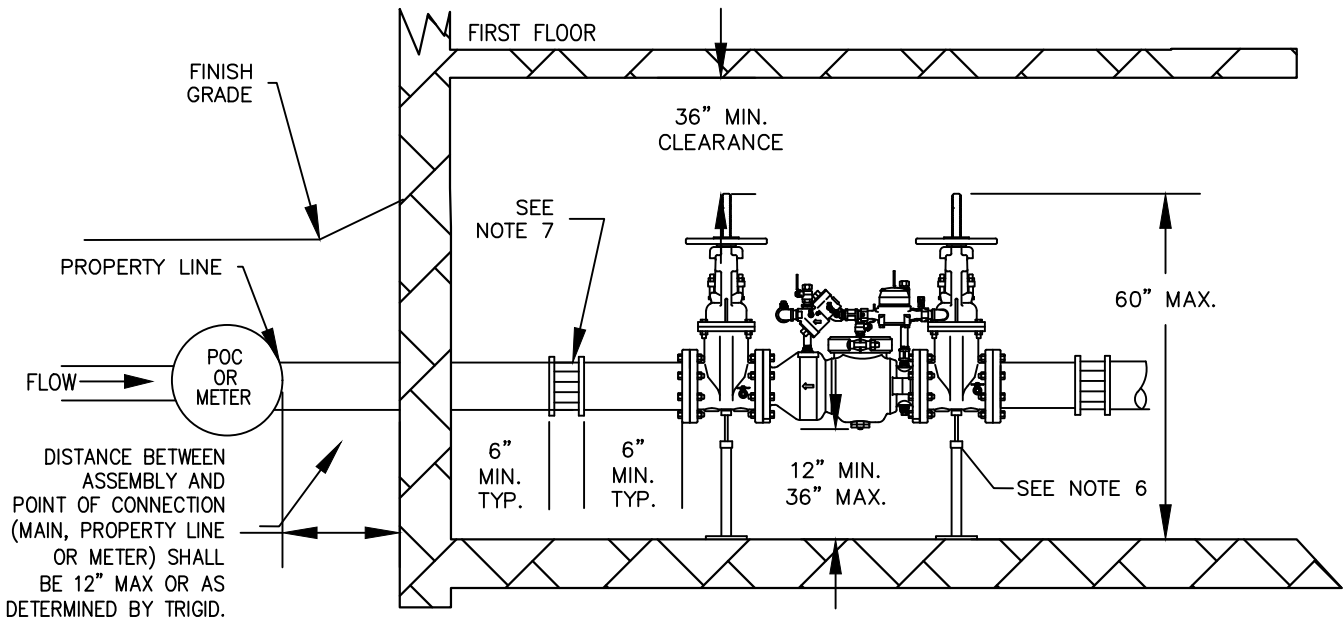
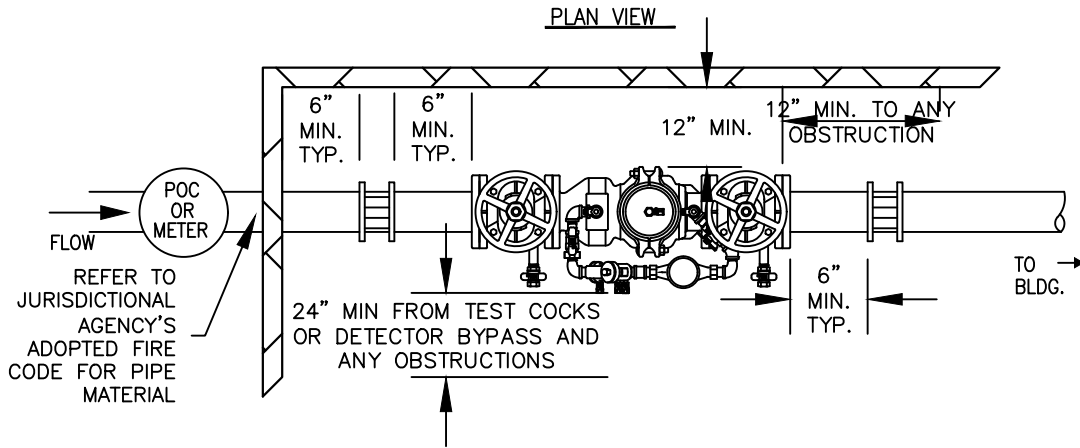

NOTES:

1. ASSEMBLY SHALL BE A USC APPROVED DEVICE.
2. NO STOP AND WASTE VALVES.
3. CALL LOCAL BUILDING AND/OR FIRE DEPARTMENTS FOR DEPTH AND TYPE OF PIPE TO BE USED.
4. INSPECTION BY TRIGID PERSONNEL REQUIRED BEFORE METER IS SET OR SERVICE IS ACTIVATED.
5. TESTING OF BACKFLOW ASSEMBLY REQUIRED WITHIN 7 DAYS AFTER METER IS SET OR SERVICE ACTIVATION. COPY OF TEST RESULTS TO BE FORWARDED TO TRIGID PERSONNEL BY A CERTIFIED ASSEMBLY TESTER WITHIN THAT SAME TIMEFRAME.
6. A MINIMUM OF 2 ADJUSTABLE PIPE STANDS TO BE USED.
7. UNIONS TO BE INSTALLED WITH ALL ASSEMBLIES ON BOTH SIDES OF ASSEMBLY.
8. VALVES ON DETECTOR BYPASS SHALL REMAIN OPEN AT ALL TIMES.
9. TRIGID MUST APPROVE THE USE OF INTERNAL BACKFLOW ASSEMBLIES.

SOURCE: TMWA DETAIL 10A-9



DRAWN: \_\_\_\_\_ NT  
CHECKED: \_\_\_\_\_ CLR  
REV: \_\_\_\_\_ MAY 2024  
REV: \_\_\_\_\_

STANDARD DETAIL

**FIRE - CLASS 1, 2, & 3, DOUBLE CHECK  
VALVE DETECTOR ASSEMBLY,  
INTERNAL, BASEMENT INSTALLATION**

WATER

2.4.6

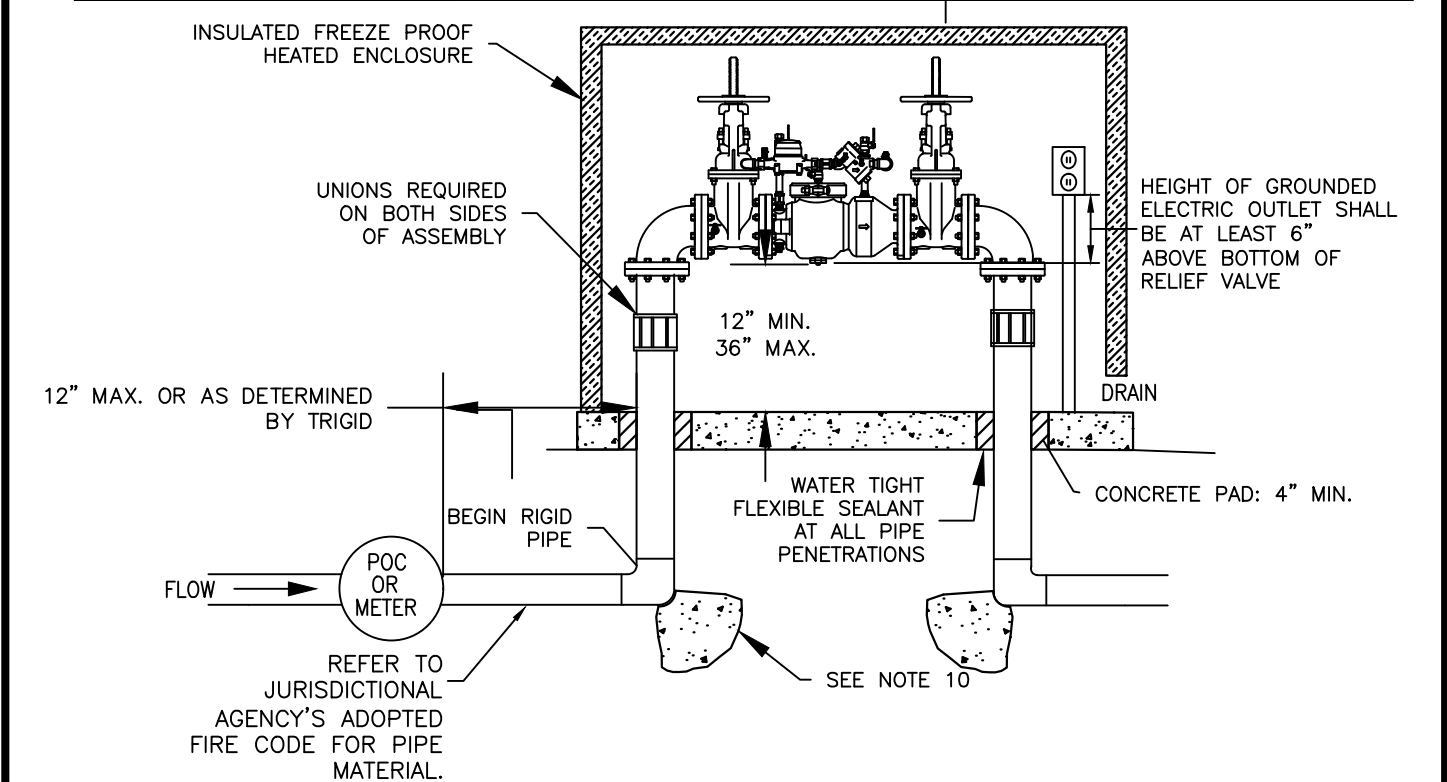
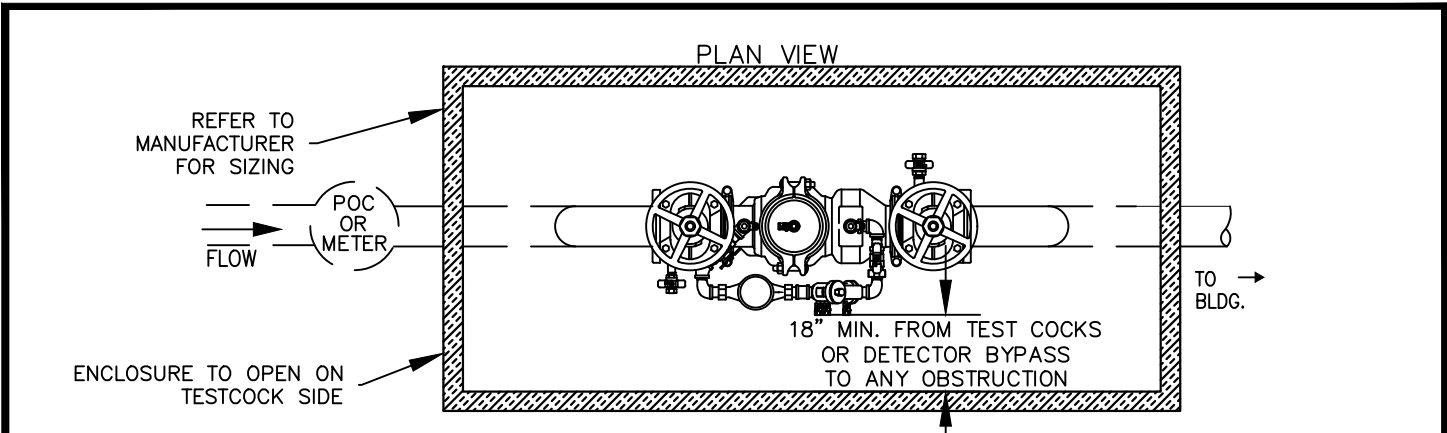

NOTES:

1. ASSEMBLY SHALL BE A USC APPROVED LEAD FREE DEVICE.
2. THE RP SHALL BE INSTALLED ABOVE GRADE.
3. FREEZE PROOF INSULATED BOX AND 1 SOURCE OF HEAT ARE REQUIRED. 2 SOURCES OF HEAT ARE STRONGLY RECOMMENDED.
4. NO STOP AND WASTE VALVES.
5. INSULATED BOX SHALL SWING CLEAR OF ASSEMBLY TO PROVIDE CLEARANCES SHOWN IN PLAN VIEW OR INSULATED BOX SHALL BE SIZED TO PROVIDE CLEARANCES SHOWN IN PLAN VIEW.
6. SPRING LOADED LID REQUIRED ON LARGE BOXES.
7. CALL LOCAL BUILDING AND/OR FIRE DEPARTMENTS FOR DEPTH AND TYPE OF PIPE TO BE USED.
8. INSPECTION BY TRIGID PERSONNEL REQUIRED BEFORE METER IS SET OR SERVICE IS ACTIVATED.
9. TESTING OF BACKFLOW ASSEMBLY REQUIRED WITHIN 7 DAYS AFTER METER IS SET OR SERVICE ACTIVATION. COPY OF TEST RESULTS TO BE FORWARDED TO TRIGID PERSONNEL BY A CERTIFIED ASSEMBLY TESTER WITHIN THAT SAME TIMEFRAME.
10. MINIMUM DIMENSIONS FOR THE THRUST BLOCK BEARING AREA FOR PIPE 2" AND SMALLER SHALL BE 8" X 8" AND 12" IN DEPTH. ALL OTHER SIZES TO BE DETERMINED BY TRIGID ENGINEER.

SOURCE: TMWA DETAIL 10A-10



DRAWN: \_\_\_\_\_ NT  
 CHECKED: \_\_\_\_\_ CLR  
 REV: \_\_\_\_\_ MAY 2024  
 REV: \_\_\_\_\_

STANDARD DETAIL

**FIRE - CLASS 4, 5, & 6 REDUCED PRESSURE  
 PRINCIPLE DETECTOR ASSEMBLY,  
 EXTERNAL, HORIZONTAL**

WATER

2.4.7

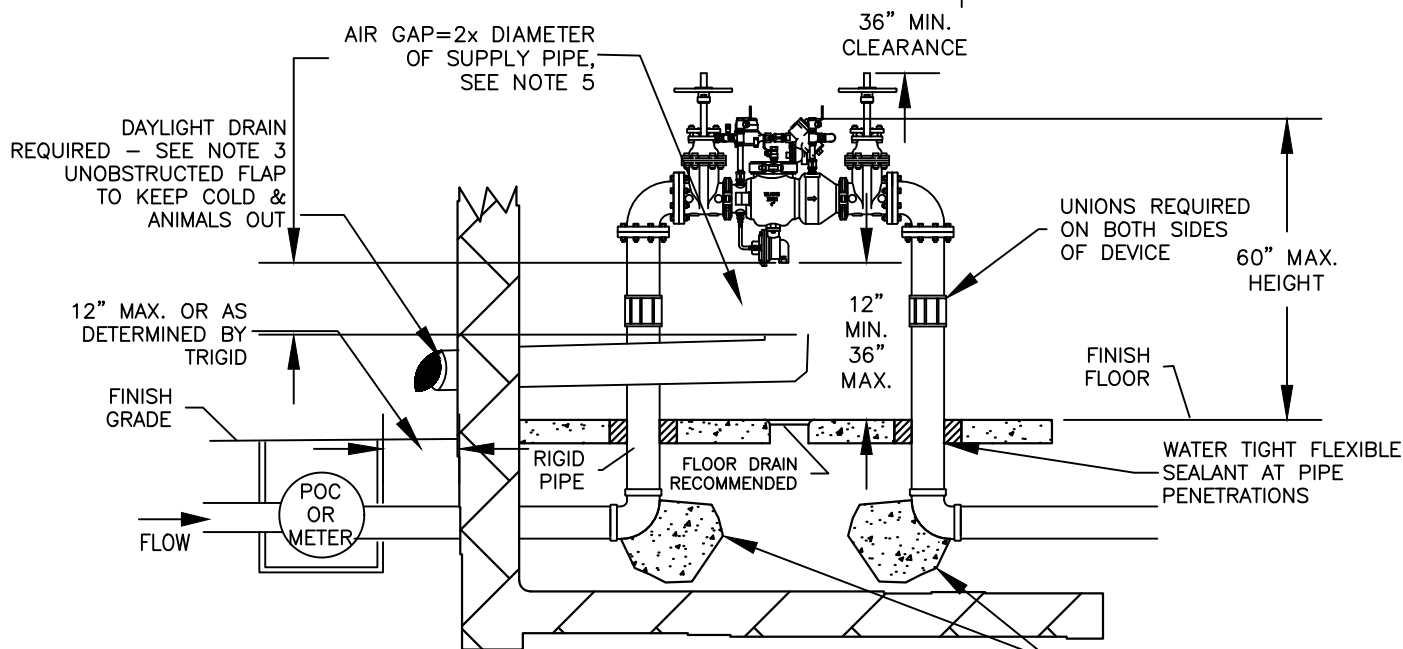
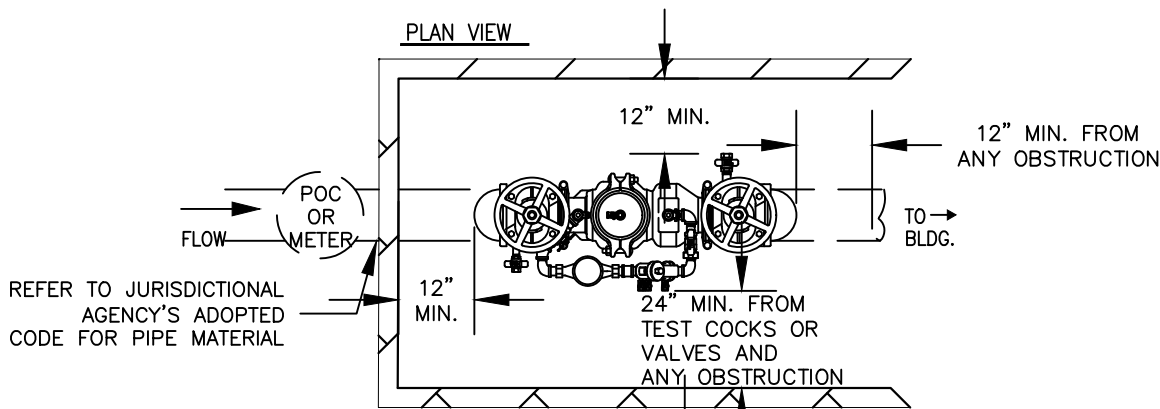

NOTES:

1. ASSEMBLY SHALL BE A USC APPROVED LEAD FREE DEVICE.
2. THE RP SHALL BE INSTALLED ABOVE GRADE AND NOT IN A BASEMENT.
3. A DAYLIGHT DRAIN IS REQUIRED AND A FLOOR DRAIN IS RECOMMENDED. DAYLIGHT DRAIN SHOULD BE NO SMALLER THAN THE RP DEVICE THAT IS INSTALLED.
4. NO STOP AND WASTE VALVES.
5. AN AIR GAP (VERTICAL PHYSICAL SEPARATION) OF AT LEAST TWICE THE DIAMETER OF THE RELIEF VALVE OPENING, IF THE PIPE IS AFFECTED BY SIDE WALLS, CLEARANCE SHALL BE AT LEAST THREE TIMES THE EFFECTIVE DIAMETER OF THE PIPE, A MINIMUM OF 1" SHALL BE MAINTAINED BETWEEN THE WATER DISCHARGE POINT ON THE RELIEF VALVE AND THE DRAIN OR MAXIMUM FLOOD LEVEL, WHICHEVER IS HIGHEST.
6. CALL LOCAL BUILDING AND/OR FIRE DEPARTMENTS FOR DEPTH AND TYPE OF PIPE TO BE USED.
7. INSPECTION BY TRIGID PERSONNEL REQUIRED BEFORE METER IS SET OR SERVICE IS ACTIVATED.
8. TESTING OF BACKFLOW ASSEMBLY REQUIRED WITHIN 7 DAYS AFTER METER IS SET OR SERVICE ACTIVATION. COPY OF TEST RESULTS TO BE FORWARDED TO TRIGID PERSONNEL BY A CERTIFIED ASSEMBLY TESTER WITHIN THAT SAME TIMEFRAME.
9. MINIMUM DIMENSIONS FOR THE THRUST BLOCK BEARING AREA FOR PIPE 2" AND SMALLER SHALL BE 8" X 8" AND 12" IN DEPTH. ALL OTHER SIZES TO BE DETERMINED BY TRIGID ENGINEER.

SOURCE: TMWA DETAIL 10A-11



DRAWN: \_\_\_\_\_ NT  
 CHECKED: \_\_\_\_\_ CLR  
 REV: \_\_\_\_\_ MAY 2024  
 REV: \_\_\_\_\_

STANDARD DETAIL  
 FIRE - CLASS 4, 5, & 6 REDUCED PRESSURE  
 PRINCIPLE DETECTOR ASSEMBLY, INTERNAL,  
 HORIZONTAL

WATER

2.4.8

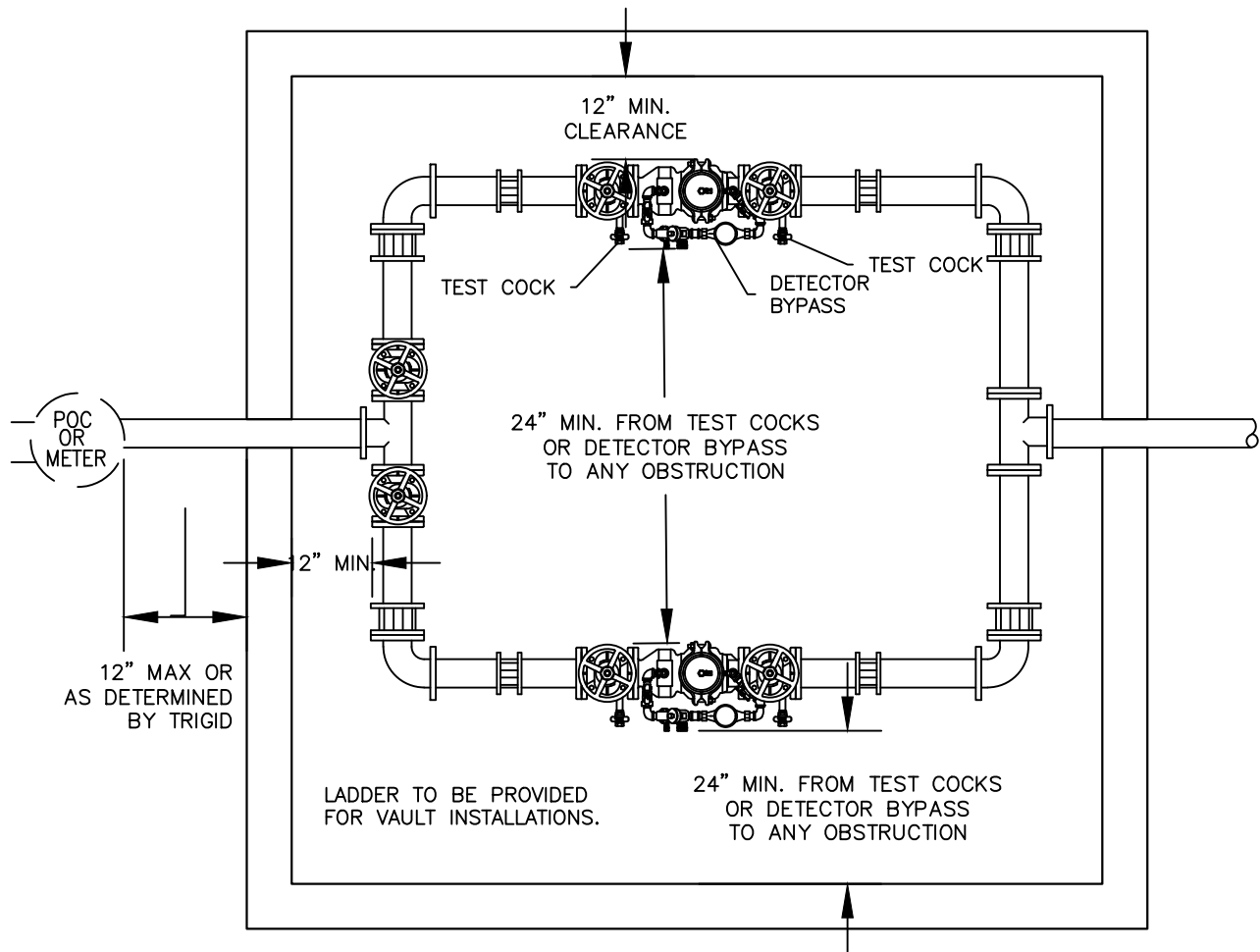

NOTES:

1. ASSEMBLY SHALL BE A USC APPROVED DEVICE.
2. THE ENTIRE MANIFOLD SHALL BE EXPOSED WITHIN THE ABOVE GROUND BOX OR BELOW GROUND VAULT.
3. REFER TO THE RP OR DC STANDARD FOR INSTALLATION DETAILS.
4. SUPPORTS SHALL BE PROVIDED AS NECESSARY.
5. FOR VAULT INSTALLATION REFER TO DETAIL 2.4.2 FOR DEPTH, PIPING, LADDER, VAULT AND PENETRATION REQUIREMENTS.
6. NO STOP AND WASTE VALVES.
7. CALL LOCAL BUILDING AND/OR FIRE DEPARTMENTS FOR DEPTH AND TYPE OF PIPE TO BE USED.
8. INSPECTION BY TRIGID PERSONNEL REQUIRED BEFORE METER IS SET OR SERVICE IS ACTIVATED.
9. TESTING OF BACKFLOW ASSEMBLY REQUIRED WITHIN 7 DAYS AFTER METER IS SET OR SERVICE ACTIVATION. COPY OF TEST RESULTS TO BE FORWARDED TO TRIGID PERSONNEL BY A CERTIFIED ASSEMBLY TESTER WITHIN THAT SAME TIMEFRAME.

SOURCE: TMWA DETAIL 10A-12

 <p>440 USA PKWY, SUITE 105 McCARRAN, NEVADA 89437</p>	DRAWN: _____ NT CHECKED: _____ CLR REV: _____ MAY 2024 REV: _____	STANDARD DETAIL FIRE - CLASS 1-6 CONTINUOUS FLOW SERVICES MANIFOLD FOR PARALLEL BACKFLOW ASSEMBLIES	WATER  2.4.9

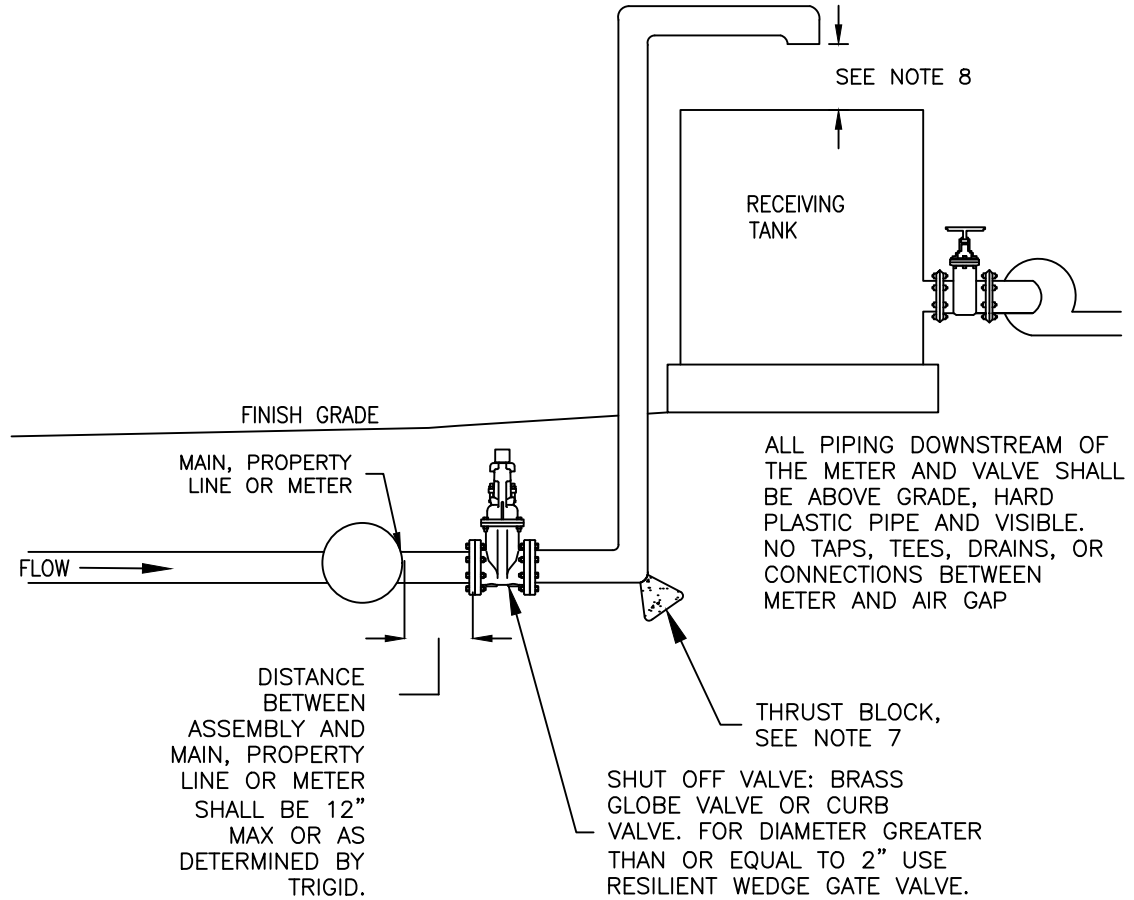

NOTES:

1. IF THE AIR GAP IS INSTALLED IN AN AREA WHERE CORROSIVE FUMES OR GASES COULD RENDER THE ASSEMBLY INEFFECTIVE, AN RP MAY BE REQUIRED UPSTREAM ON THE SERVICE LINE.
2. NO STOP AND WASTE VALVES.
3. THE AIR GAP SHALL BE READILY ACCESSIBLE FOR INSPECTION.
4. THE AIR GAP SHALL REMAIN OPERATIVE AND EFFECTIVE THROUGHOUT THE YEAR WITHOUT BEING BYPASSED. TRIGID SHALL BE NOTIFIED OF ANY BYPASS INSTALLED.
5. CALL LOCAL BUILDING AND/OR FIRE DEPARTMENTS FOR DEPTH AND TYPE OF PIPE TO BE USED.
6. INSPECTION BY TRIGID PERSONNEL REQUIRED BEFORE METER IS SET OR SERVICE IS ACTIVATED.
7. THRUST BLOCKS REQUIRED ON ALL BELOW GRADE ELBOWS. SIZE TO BE VERIFIED BY TRIGID ENGINEER.
8. AIR GAP MUST BE AT LEAST TWICE THE EFFECTIVE DIAMETER OF THE PIPE OR IF THE PIPE IS AFFECTED BY SIDE WALLS, AT LEAST THREE TIMES THE EFFECTIVE DIAMETER OF THE PIPE. IN NO CASE SHALL THE AIR GAP BE LESS THAN 1".

SOURCE: TMWA DETAIL 10A-13



DRAWN: \_\_\_\_\_ NT  
 CHECKED: \_\_\_\_\_ CLR  
 REV: \_\_\_\_\_ MAY 2024  
 REV: \_\_\_\_\_

STANDARD DETAIL

WATER

AIR GAP SEPARATION

2.4.10

NOTES:

1. REFERENCE TRIGID STANDARD DETAIL 2.14 FOR THRUST BLOCK SIZING AND REQUIREMENTS (DEAD END CONDITION).
2. ALL EXPOSED METAL SHALL BE COATED WITH BRUSHED-ON MASTIC.
3. ALL BOLTS AND ASSOCIATED HARDWARE SHALL BE FLUOROPOLYMER COATED.
4. TEE, VALVE, FITTINGS, DUCTILE IRON PIPE, AND OTHER METAL PARTS SHALL BE ENCASED WITH POLYETHYLENE WRAP PER AWWA C105.
5. CONCRETE FOR PADS SHALL HAVE A COMPRESSIVE STRENGTH OF NOT LESS THAN 3,000 PSI AFTER 28 DAYS. BAG CONCRETE MIX IS NOT ACCEPTABLE.
6. ALL PIPE AND FITTINGS IN CONTACT WITH WATER SHALL BE NSF-61 CERTIFIED.

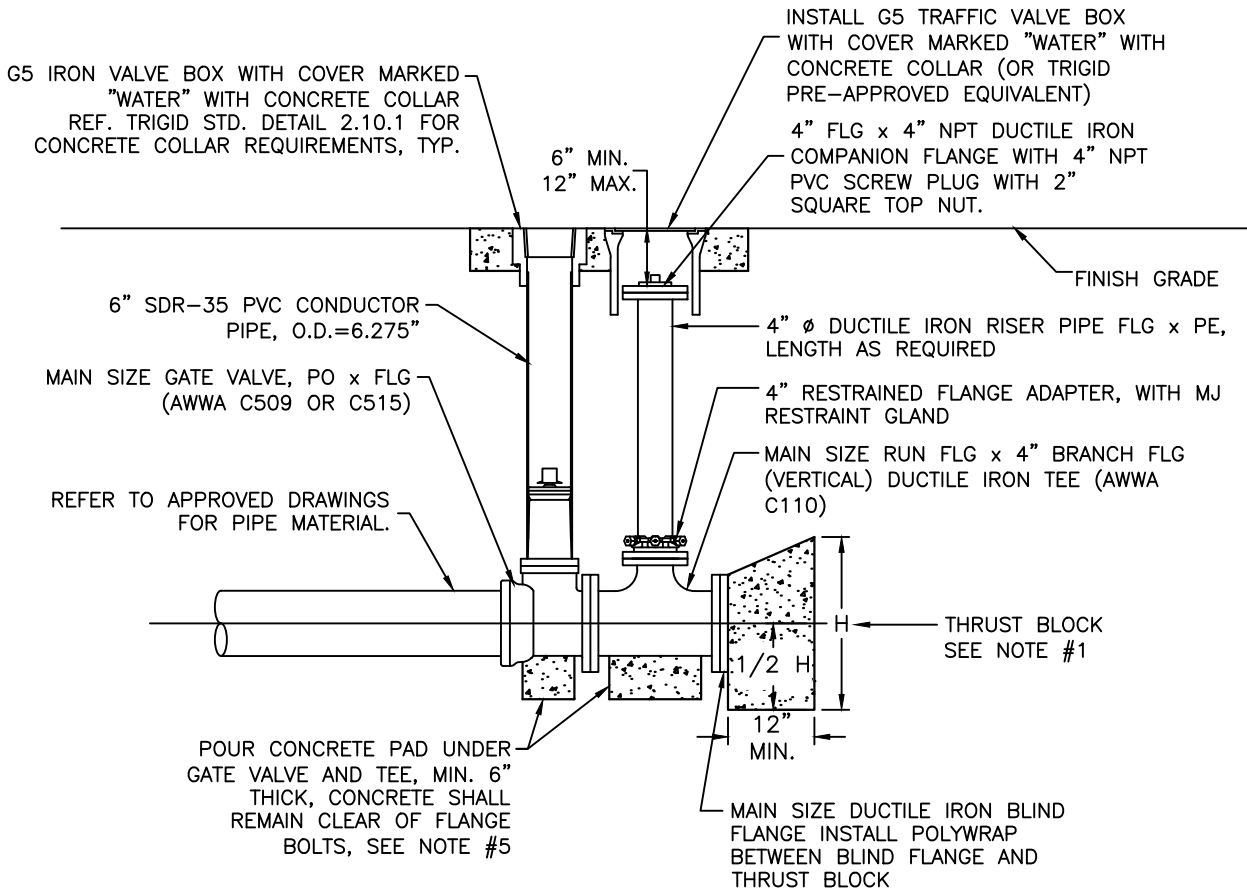

MATERIAL LIST

QTY.	DESCRIPTION
1	MAIN SIZE RUN FLG x 4" BRANCH FLG DUCTILE IRON TEE (AWWA C110)
1	MAIN SIZE GATE VALVE, PO x FLG, (AWWA C509 OR C515)
1	MAIN SIZE DUCTILE IRON BLIND FLANGE
1	4" FLG x 4" NPT DUCTILE IRON COMPANION FLANGE
1	4" Ø DUCTILE IRON RISER PIPE FLG x PE (LENGTH AS REQUIRED)
1	4" RESTRAINED FLANGED ADAPTER WITH MJ RESTRAINT GLAND
1	4" PVC SCREW PLUG, NPT, WITH 2" SQUARE TOP NUT
2	G5 TRAFFIC VALVE BOX WITH COVER MARKED "WATER"
1	6" SDR-35 PVC CONDUIT PIPE SECTION, O.D.=6.275"
-	CONCRETE BULK - THRUST BLOCKS, PADS, COLLARS

SOURCE: TMWA DETAIL 10E-2



DRAWN: \_\_\_\_\_ NT  
 CHECKED: \_\_\_\_\_ CLR  
 REV: \_\_\_\_\_ MAY 2024  
 REV: \_\_\_\_\_

STANDARD DETAIL

**PERMANENT DEAD-END  
 LOCATION FLUSH ASSEMBLY**

WATER

2.5.1

NOTES:

1. ALL EXPOSED METAL SHALL BE COATED WITH BRUSHED-ON MASTIC.
2. ALL BOLTS AND ASSOCIATED HARDWARE SHALL BE FLUOROPOLYMER COATED.
3. TEE, VALVE, FITTINGS, DUCTILE IRON PIPE, AND OTHER METAL PARTS SHALL BE ENCASED WITH POLYETHYLENE WRAP PER AWWA C105.
4. CONCRETE FOR PADS SHALL HAVE A COMPRESSIVE STRENGTH OF NOT LESS THAN 3,000 PSI AFTER 28 DAYS. BAG CONCRETE MIX IS NOT ACCEPTABLE.
6. ALL PIPE AND FITTINGS IN CONTACT WITH WATER SHALL BE NSF-61 CERTIFIED.

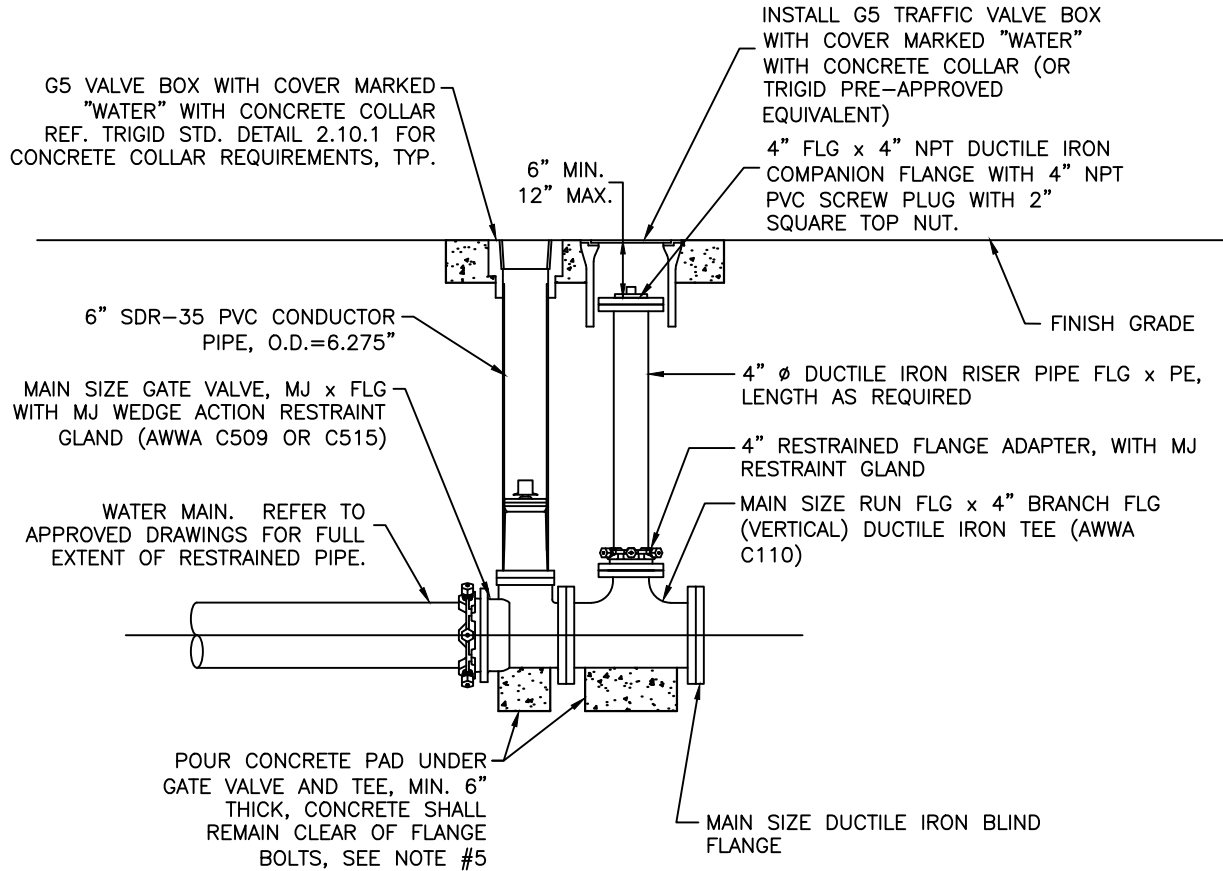

MATERIAL LIST

QTY.	DESCRIPTION
1	MAIN SIZE RUN FLG x 4" BRANCH FLG DUCTILE IRON TEE (AWWA C110)
1	MAIN SIZE GATE VALVE, MJ x FLG, (AWWA C509 OR C515)
1	MAIN SIZE MJ WEDGE ACTION RESTRAINT GLAND
1	MAIN SIZE DUCTILE IRON BLIND FLANGE
1	4" FLG x 4" NPT DUCTILE IRON COMPANION FLANGE
1	4" Ø DUCTILE IRON RISER PIPE FLG x PE (LENGTH AS REQUIRED)
1	4" RESTRAINED FLANGE ADAPTER, WITH MJ RESTRAINT GLAND
1	4" PVC SCREW PLUG, NPT, WITH 2" SQUARE TOP NUT
2	G5 TRAFFIC VALVE BOX WITH COVER MARKED "WATER"
1	6" SDR-35 PVC CONDUIT PIPE SECTION, O.D.=6.275"
-	CONCRETE BULK - PADS, COLLARS

SOURCE: TMWA DETAIL 10E-3



DRAWN: \_\_\_\_\_ NT  
 CHECKED: \_\_\_\_\_ CLR  
 REV: \_\_\_\_\_ MAY 2024  
 REV: \_\_\_\_\_

STANDARD DETAIL

**TEMPORARY DEAD-END  
 FLUSH ASSEMBLY**

WATER

**2.5.2**



NOTES:

1. ALL EXPOSED METAL SHALL BE COATED WITH BRUSHED-ON MASTIC.
2. ALL BOLTS AND ASSOCIATED HARDWARE SHALL BE FLUOROPOLYMER COATED.
3. TEE, VALVES, FITTINGS, DUCTILE IRON PIPE, AND OTHER METAL PARTS SHALL BE ENCASED WITH POLYETHYLENE WRAP PER AWWA C105.
4. CONCRETE FOR PADS SHALL HAVE A COMPRESSIVE STRENGTH OF NOT LESS THAN 3,000 PSI AFTER 28 DAYS. BAG CONCRETE MIX IS NOT ACCEPTABLE.
5. ALL PIPE AND FITTINGS IN CONTACT WITH WATER SHALL BE NSF-61 CERTIFIED.
6. MJ x FLG GATE VALVES WITH MJ WEDGE ACTION RESTRAINT GLANDS MAY BE REQUIRED IN LIEU OF PO x FLG GATE VALVES, REFERENCE WATER IMPROVEMENT PLANS.

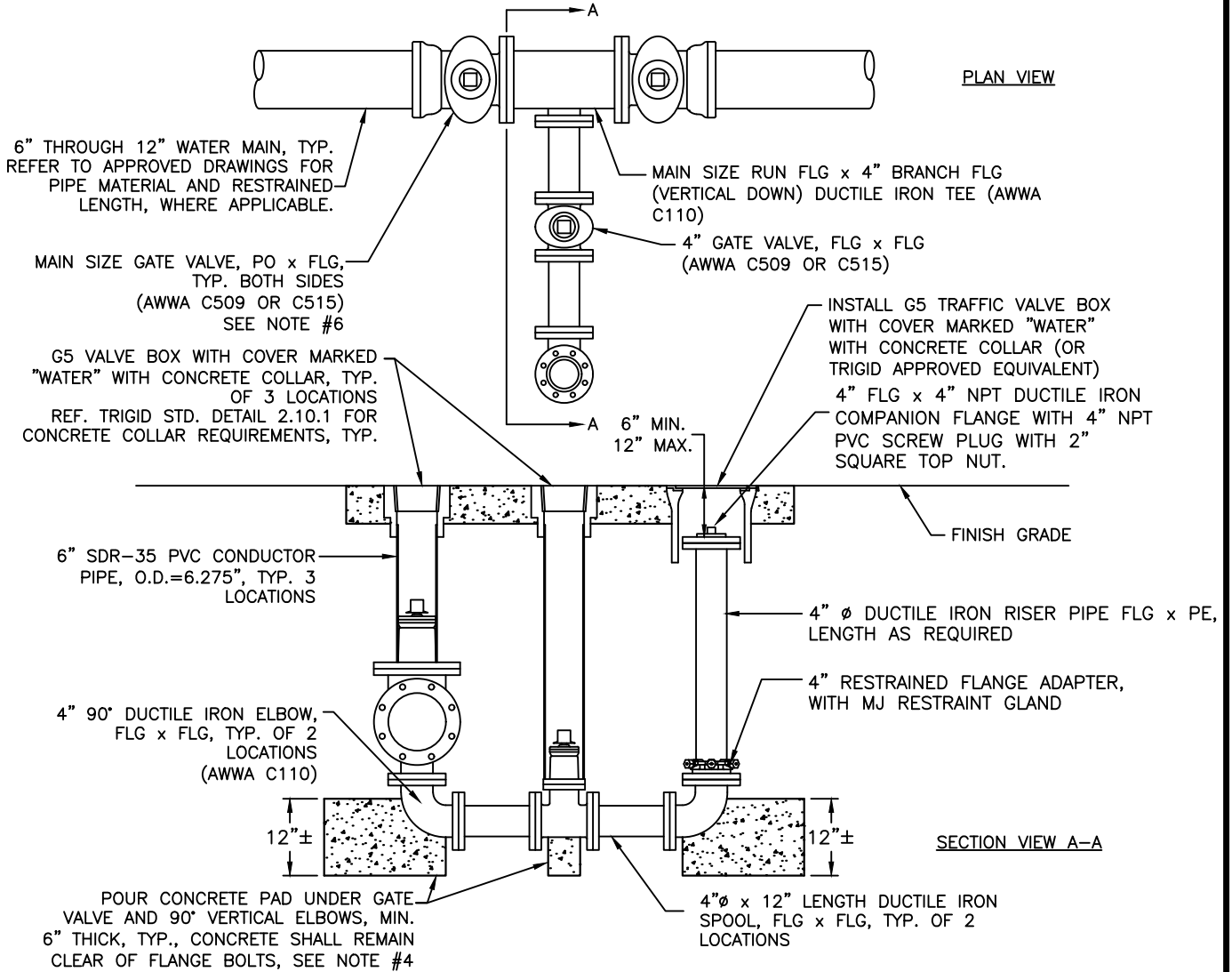

MATERIAL LIST	
QTY.	DESCRIPTION
1	MAIN SIZE RUN FLG x 4" BRANCH FLG DUCTILE IRON TEE (AWWA C110)
2	MAIN SIZE GATE VALVE, PO x FLG, (AWWA C509 OR C515)
1	4" GATE VALVE, FLG x FLG, (AWWA C509 OR C515)
2	4" 90° DUCTILE IRON ELBOW, FLG x FLG (AWWA C110)
2	4"φ x 12" LENGTH DUCTILE IRON SPOOL, FLG x FLG
1	4" FLG x 4" NPT DUCTILE IRON COMPANION FLANGE
1	4" RESTRAINED FLANGE ADAPTER, WITH MJ RESTRAINT GLAND

MATERIAL LIST (CONT.)	
QTY.	DESCRIPTION
1	4"φ DUCTILE IRON SPOOL, FLG x PE (LENGTH AS REQUIRED)
1	4" PVC SCREW PLUG, NPT, WITH 2" SQUARE TOP NUT
4	CHRISTY G5 TRAFFIC VALVE BOX WITH COVER MARKED "WATER"
3	6" SDR-35 PVC CONDUIT PIPE SECTION, O.D.=6.275"
-	CONCRETE BULK - THRUST BLOCKS, PADS, COLLARS

SOURCE: TMWA DETAIL 10E-4



DRAWN: \_\_\_\_\_ NT  
 CHECKED: \_\_\_\_\_ CLR  
 REV: \_\_\_\_\_ MAY 2024  
 REV: \_\_\_\_\_

STANDARD DETAIL

WATER

BLOW-OFF ASSEMBLY

2.5.3

NOTES:

1. ALL EXPOSED METAL SHALL BE COATED WITH BRUSHED-ON MASTIC.
2. ALL BOLTS AND ASSOCIATED HARDWARE SHALL BE FLUOROPOLYMER COATED.
3. TEE, VALVES, FITTINGS, DUCTILE IRON PIPE, AND OTHER METAL PARTS SHALL BE ENCASED WITH POLYETHYLENE WRAP PER AWWA C105.
4. CONCRETE FOR PADS SHALL HAVE A COMPRESSIVE STRENGTH OF NOT LESS THAN 3,000 PSI AFTER 28 DAYS. BAG CONCRETE MIX IS NOT ACCEPTABLE.
5. ALL PIPE AND FITTINGS IN CONTACT WITH WATER SHALL BE NSF-61 CERTIFIED.
6. MJ x FLG GATE VALVES WITH MJ WEDGE ACTION RESTRAINT GLANDS MAY BE REQUIRED IN LIEU OF PO x FLG GATE VALVES, REFERENCE WATER IMPROVEMENT PLANS.

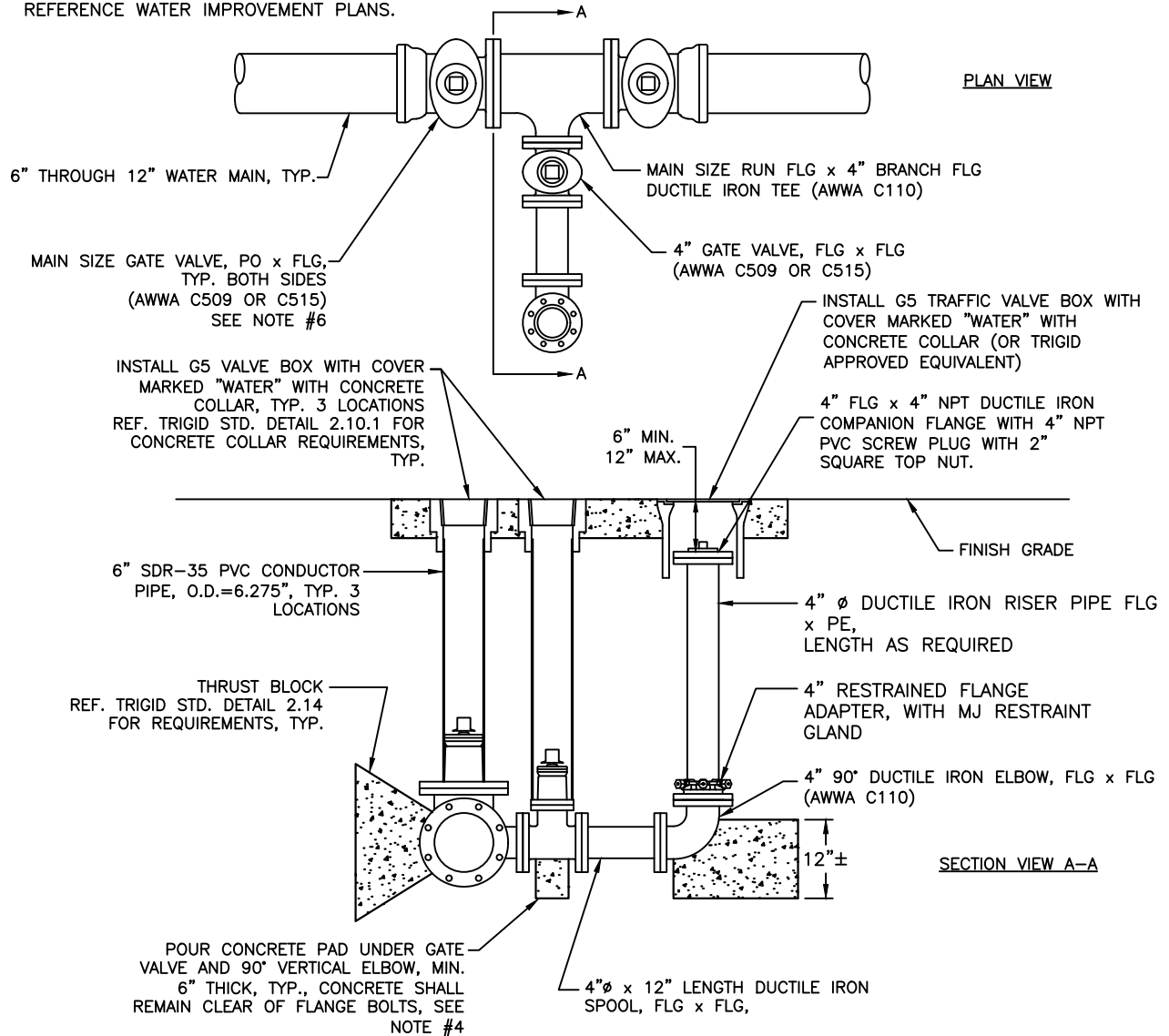

MATERIAL LIST	
QTY.	DESCRIPTION
1	MAIN SIZE RUN FLG x 4" BRANCH FLG DUCTILE IRON TEE (AWWA C110)
2	MAIN SIZE GATE VALVE, PO x FLG, (AWWA C509 OR C515)
1	4" GATE VALVE, FLG x FLG, (AWWA C509 OR C515)
1	4" 90° DUCTILE IRON ELBOW, FLG x FLG (AWWA C110)
1	4" x 12" LENGTH DUCTILE IRON SPOOL, FLG x FLG
1	4" FLG x 4" NPT DUCTILE IRON COMPANION FLANGE
1	4" RESTRAINED FLANGE ADAPTER WITH MJ RESTRAINT GLAND

MATERIAL LIST (CONT.)	
QTY.	DESCRIPTION
1	4" DUCTILE IRON SPOOL, FLG x PE (LENGTH AS REQUIRED)
1	4" PVC SCREW PLUG, NPT, WITH 2" SQUARE TOP NUT
4	CHRISTY G5 TRAFFIC VALVE BOX WITH COVER MARKED "WATER"
3	6" SDR-35 PVC CONDUIT PIPE SECTION, O.D.=6.275"
-	CONCRETE BULK - THRUST BLOCKS, PADS, COLLARS

SOURCE: TMWA DETAIL 10E-5



DRAWN: \_\_\_\_\_ NT  
 CHECKED: \_\_\_\_\_ CLR  
 REV: \_\_\_\_\_ MAY 2024  
 REV: \_\_\_\_\_

STANDARD DETAIL

# IN-LINE FLUSH ASSEMBLY

WATER

# 2.5.4

NOTES:

1. REFERENCE TRIGID STANDARD DETAIL 2.14 FOR THRUST BLOCK SIZING AND REQUIREMENTS (DEAD END CONDITION) FOR PERMANENT FLUSH VALVE ASSEMBLIES.
2. ALL EXPOSED METAL SHALL BE COATED WITH BRUSHED-ON MASTIC.
3. ALL BOLTS AND ASSOCIATED HARDWARE SHALL BE FLUOROPOLYMER COATED.
4. TEE, VALVE, FITTINGS, DUCTILE IRON PIPE, AND OTHER METAL PARTS SHALL BE ENCASED WITH POLYETHYLENE WRAP PER AWWA C105.
5. CONCRETE FOR PADS SHALL HAVE A COMPRESSIVE STRENGTH OF NOT LESS THAN 3,000 PSI AFTER 28 DAYS. BAG CONCRETE MIX IS NOT ACCEPTABLE.
6. RETIREMENT REQUIRES REMOVAL OF 4" DUCTILE IRON RISER WITH TAP AND ALL ASSOCIATED 2" CTS HDPE TUBING AND METER BOX. REPLACE WITH NEW 4" DUCTILE IRON FLG x PE SPOOL.
7. ALL PIPE AND FITTINGS IN CONTACT WITH WATER SHALL BE NSF-61 CERTIFIED.

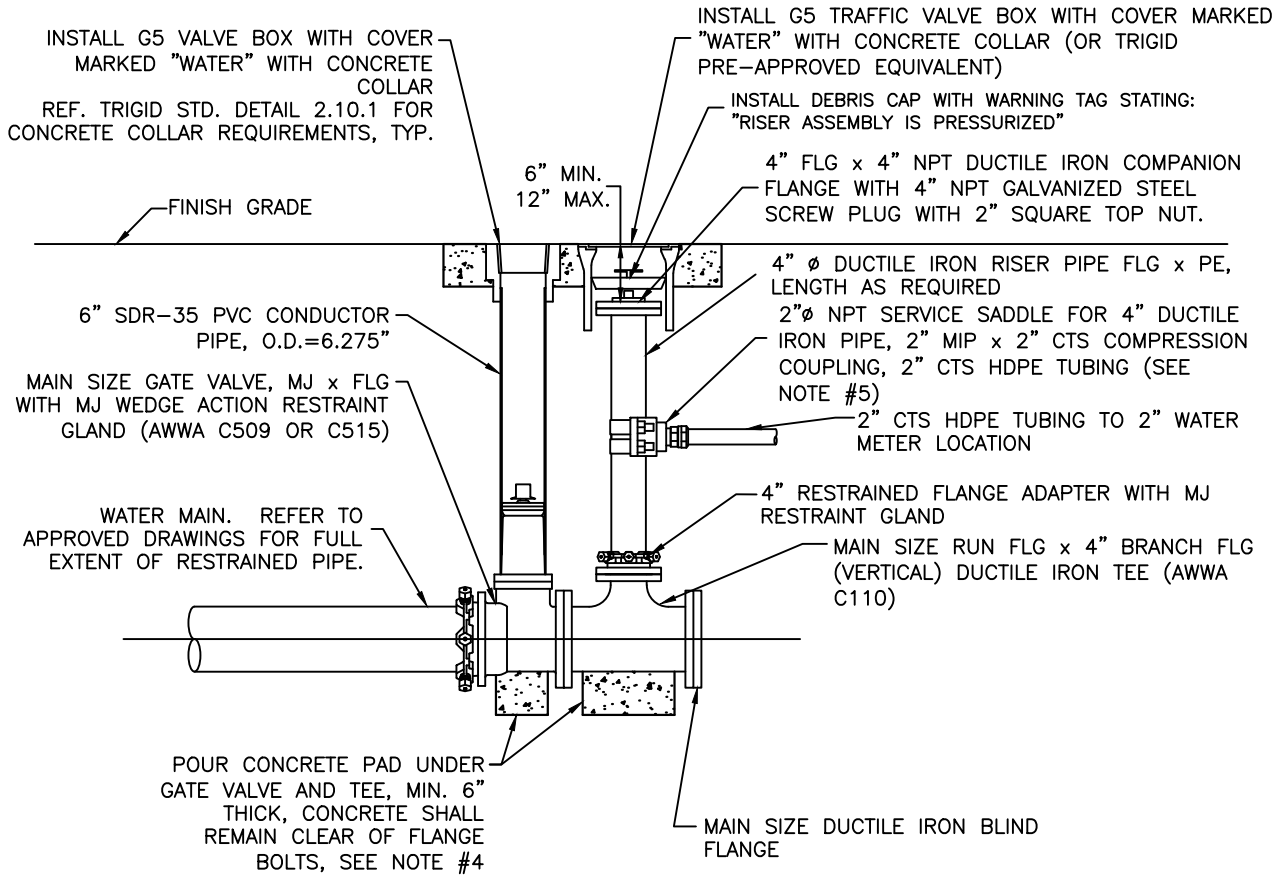

FOR EXISTING FLUSH VALVE ASSEMBLIES:

- ENSURE THAT PLUG IS PRESSURE RATED. PVC SCREW PLUGS SHALL BE REPLACED TO CONFORM TO THIS DETAIL.
- NOT ALL EXISTING FLUSH VALVE ASSEMBLIES WILL BE CONNECTED TO MECHANICALLY RESTRAINED PIPE; THRUST BLOCKS AT THE END OF THE MAIN SHALL NOT BE DISTURBED.
- RISER SHALL BE REPLACED TO THE ABOVE SPECIFICATIONS.

SOURCE: TMWA DETAIL 10E-6



DRAWN: \_\_\_\_\_ NT  
 CHECKED: \_\_\_\_\_ CLR  
 REV: \_\_\_\_\_ MAY 2024  
 REV: \_\_\_\_\_

STANDARD DETAIL  
**FLUSH ASSEMBLY FOR  
 CONSTRUCTION WATER SERVICE**

WATER

2.5.5

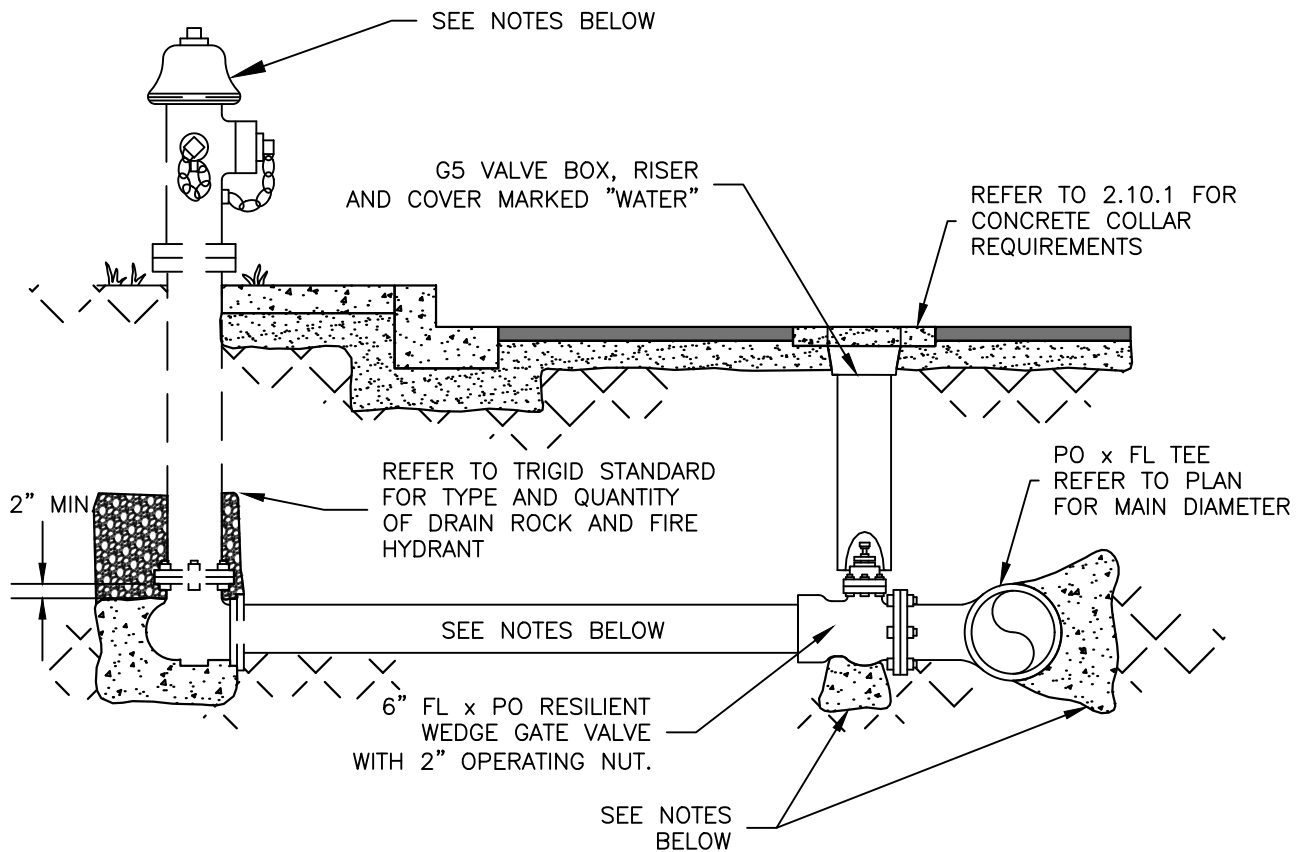

NOTES:

1. REFERENCE NAC 445A, TRIGID CONSTRUCTION AND DESIGN STANDARDS FOR REQUIRED PIPE MATERIALS. POLYETHYLENE WRAP TO BE USED ON ALL DUCTILE IRON PIPE AND FITTINGS PER AWWA C105.
2. REFER TO PLAN FOR ACTUAL DIAMETER AND LENGTH FOR HYDRANT LATERAL.
3. KEEP A MINIMUM OF 2" CLEARANCE BETWEEN FLANGES/BOLTS AND CONCRETE.
4. LOCATION OF FIRE HYDRANT TO BE DETERMINED BY APPROPRIATE GOVERNMENTAL FIRE AGENCY. FIRE HYDRANT AND BARREL EXTENSION TO BE SUPPLIED BY OTHERS.
5. HYDRANT COLOR SHALL BE RED
6. ALL EXPOSED METAL MUST BE COATED AND WRAPPED.
7. REFER TO TRIGID STANDARDS OR DETAILS 2.14-2.21 FOR THRUST BLOCK REQUIREMENTS. USE THE MOST CONSERVATIVE.

SOURCE: TMWA DETAIL 10F-2



DRAWN: \_\_\_\_\_ NT  
 CHECKED: \_\_\_\_\_ CLR  
 REV: \_\_\_\_\_ MAY 2024  
 REV: \_\_\_\_\_

STANDARD DETAIL

**6" FIRE HYDRANT SERVICE  
 OFF NEW MAINS**

WATER

**2.6.1**

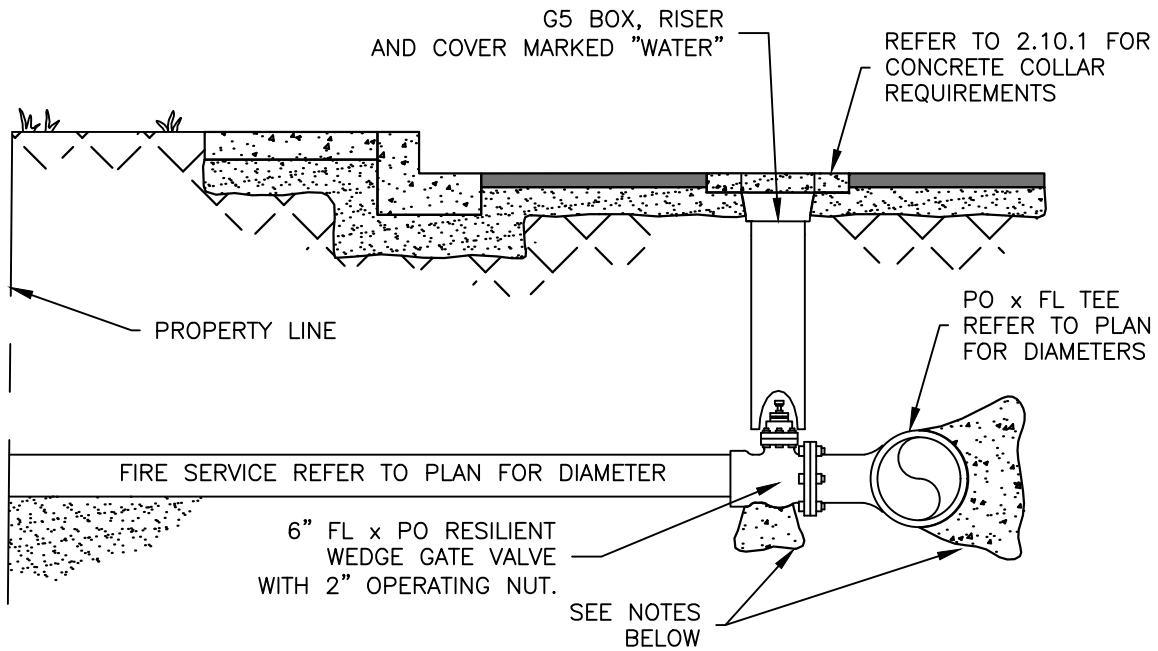

NOTES:

1. REFERENCE NAC 445A, TRIGID CONSTRUCTION AND DESIGN STANDARDS FOR REQUIRED PIPE MATERIALS. POLYETHYLENE WRAP TO BE USED ON ALL DUCTILE IRON PIPE AND FITTINGS PER AWWA C105.
2. REFER TO PLAN FOR ACTUAL DIAMETER AND LENGTH FOR FIRE SERVICE LATERAL.
3. KEEP A MINIMUM OF 2" CLEARANCE BETWEEN FLANGES/BOLTS AND CONCRETE.
4. ALL EXPOSED METAL MUST BE COATED AND WRAPPED.
5. REFER TO TRIGID STANDARDS OR DETAILS 2.14-2.21 FOR THRUST BLOCK REQUIREMENTS. USE THE MOST CONSERVATIVE.
6. REFER TO APPROVED PLAN AND DETAILS 2.4.1-2.4.10 FOR APPROPRIATE BACKFLOW DEVICE.

SOURCE: TMWA DETAIL 10F-3



DRAWN: \_\_\_\_\_ NT  
 CHECKED: \_\_\_\_\_ CLR  
 REV: \_\_\_\_\_ MAY 2024  
 REV: \_\_\_\_\_

STANDARD DETAIL

WATER

FIRE SERVICE OFF NEW  
 MAINS

2.6.2

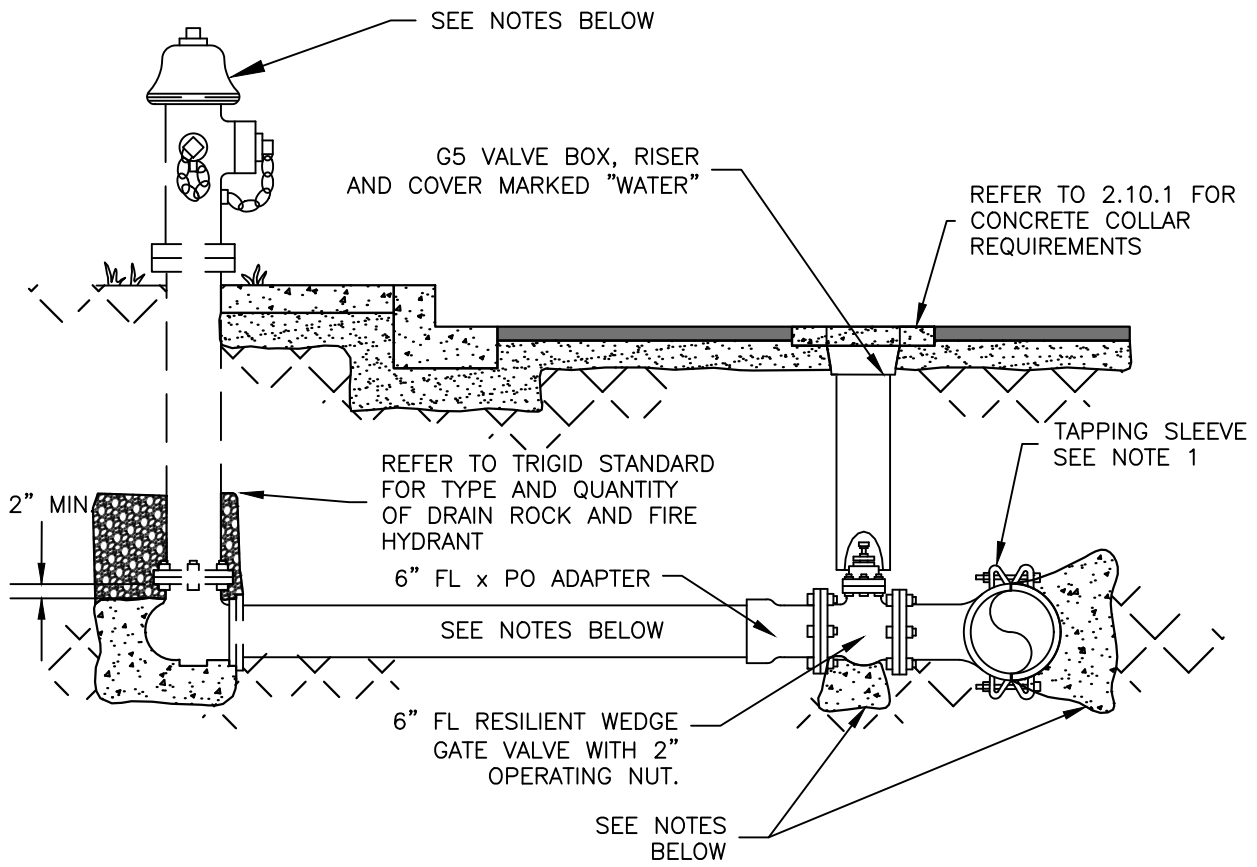

NOTES:

1. REFER TO DETAIL 2.3.1–2.3.3 FOR TAPPING SLEEVE DETAILS.
2. REFERENCE NAC 445A, TRIGID CONSTRUCTION AND DESIGN STANDARDS FOR REQUIRED PIPE MATERIALS. POLYETHYLENE WRAP TO BE USED ON ALL DUCTILE IRON PIPE AND FITTINGS PER AWWA C105.
3. REFER TO PLAN FOR ACTUAL DIAMETER AND LENGTH FOR HYDRANT LATERAL.
4. KEEP A MINIMUM OF 2" CLEARANCE BETWEEN FLANGES/BOLTS AND CONCRETE.
5. LOCATION OF FIRE HYDRANT TO BE DETERMINED BY APPROPRIATE GOVERNMENTAL FIRE AGENCY. FIRE HYDRANT AND BARREL EXTENSION TO BE SUPPLIED BY OTHERS.
6. HYDRANT COLOR SHALL BE RED
7. ALL EXPOSED METAL MUST BE COATED AND WRAPPED.
8. REFER TO TRIGID STANDARDS OR DETAILS 2.14–2.21 FOR THRUST BLOCK REQUIREMENTS. USE THE MOST CONSERVATIVE.
9. PRESSURE TEST TAPPING SLEEVE AND VALVE TO MANUFACTURER'S RECOMMENDATION.

SOURCE: TMWA DETAIL 10F-4

 <p>440 USA PKWY, SUITE 105 McCARRAN, NEVADA 89437</p>	DRAWN: _____ NT CHECKED: _____ CLR REV: _____ MAY 2024 REV: _____	STANDARD DETAIL	WATER
	<h2>6" FIRE HYDRANT SERVICE OFF EXISTING MAIN</h2>		<h1>2.6.3</h1>

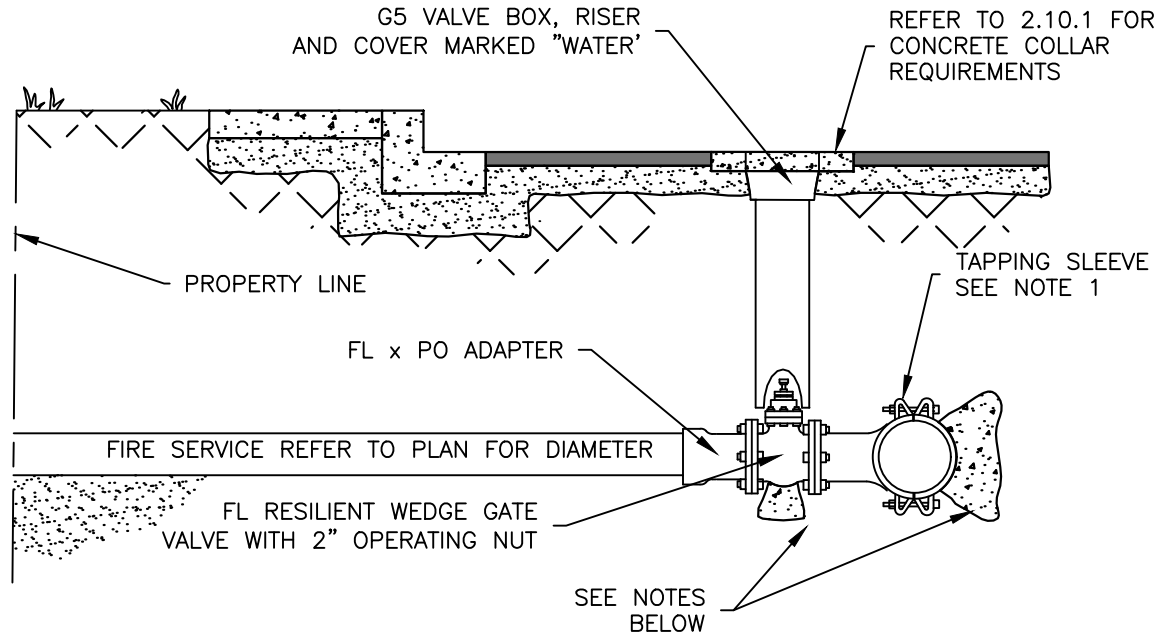

NOTES:

1. REFER TO DETAILS 2.3.1–2.3.3 FOR TAPPING SLEEVE DETAILS.
2. REFERENCE NAC 445A, TRIGID CONSTRUCTION AND DESIGN STANDARDS FOR REQUIRED PIPE MATERIALS. POLYETHYLENE WRAP TO BE USED ON ALL DUCTILE IRON PIPE AND FITTINGS PER AWWA C105.
3. REFER TO PLAN FOR DIAMETER AND LENGTH OF SERVICE LATERAL.
4. KEEP A MINIMUM OF 2" CLEARANCE BETWEEN FLANGES/BOLTS AND CONCRETE.
5. ALL EXPOSED METAL MUST BE COATED AND WRAPPED.
6. REFER TO TRIGID STANDARDS OR DETAILS 2.14–2.21 FOR THRUST BLOCK REQUIREMENTS. USE THE MOST CONSERVATIVE.
7. REFER TO APPROVED PLAN AND DETAILS 2.4.1–2.4.10 FOR APPROPRIATE BACKFLOW DEVICE.
8. PRESSURE TEST TAPPING SLEEVE AND VALVE TO MANUFACTURER'S RECOMMENDATION.

SOURCE: TMWA DETAIL 10F-5

 <p>440 USA PKWY, SUITE 105 McCARRAN, NEVADA 89437</p>	DRAWN: _____ NT CHECKED: _____ CLR REV: _____ MAY 2024 REV: _____	STANDARD DETAIL	WATER
		<b>FIRE SERVICE OFF EXISTING MAIN</b>	<b>2.6.4</b>

NOTES:

1. SERVICE CLAMP SIZE IS DEPENDENT UPON THE SIZE AND TYPE OF MAIN.
2. SDR-9 CTS HDPE TUBING, LENGTH AND DIAMETER TO BE DETERMINED BY TRIGID ENGINEER. REFER TO APPROVED PLAN.
3. STOP CORP IP THREAD INLET, COMPRESSION OUTLET, DIAMETER TO MATCH TAP SIZE AS SHOWN ON PLAN.
4. INSERT RIGID STAINLESS STEEL LINER TO SDR-9 CTS HDPE TUBING.
5. SERVICE TAPS OFF OF EXISTING PVC MAINS SHALL USE TAPPED FULL CIRCLE REPAIR CLAMP, MINIMUM LENGTH: 15". MANUFACTURER SHALL BE APPROVED BY TRIGID.

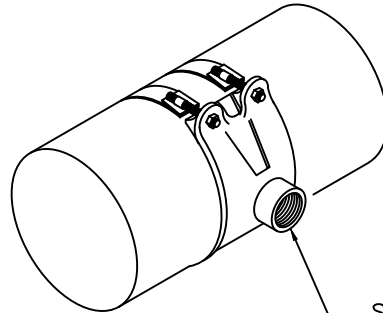
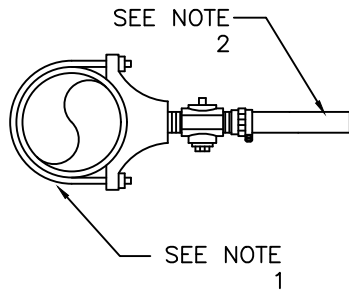

SERVICE SADDLE TO BE CONSTRUCTED OF DUCTILE IRON WITH FUSED NYLON COATING AND DOUBLE STAINLESS STEEL STRAPS. SEE NOTE 5.

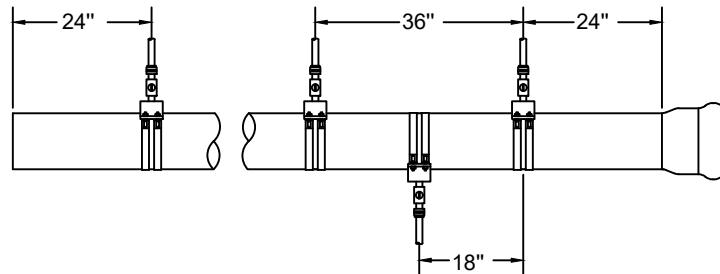

C-900  
PVC  
OR  
TRANSITE

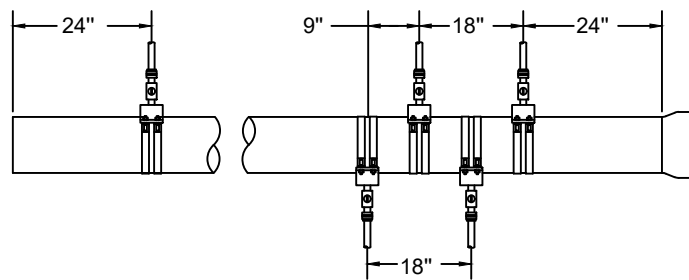

DUCTILE  
OR CAST  
IRON OR  
STEEL

SOURCE: TMWA DETAIL 10H-2



DRAWN: \_\_\_\_\_ NT  
 CHECKED: \_\_\_\_\_ CLR  
 REV: \_\_\_\_\_ MAY 2024  
 REV: \_\_\_\_\_

STANDARD DETAIL

1" TO 2" SERVICE TAP

WATER

2.8.1



NOTES:

1. REFERENCE DETAILS IN SECTION 2.21 FOR UTILITY SEPARATION REQUIREMENTS.
2. ALL RESTRAINED JOINT PIPING SHALL BE DUCTILE IRON PIPE (RJ-DIP). RESTRAINED LENGTHS OUTSIDE OUTERMOST ELBOWS SHALL BE CALCULATED BY THE DESIGN ENGINEER AND SPECIFIED ON THE WATER IMPROVEMENT PLANS.
3. RESTRAINED JOINT FITTINGS SHALL BE MECHANICAL JOINT (MJ) DUCTILE IRON RESTRAINED WITH MECHANICAL JOINT WEDGE ACTION RESTRAINT GLANDS.
4. BELL AND SPIGOT PUSH-ON JOINTS SHALL BE RESTRAINED USING RUBBER GASKETS WITH STAINLESS STEEL LOCKING SEGMENTS VULCANIZED INTO THE RUBBER GASKET.
5. ALL BOLTS AND EXPOSED METAL SHALL BE COATED WITH BRUSHED-ON MASTIC.
6. FITTINGS, DUCTILE IRON PIPE, AND OTHER METAL PARTS SHALL BE ENCASED WITH POLYETHYLENE WRAP PER AWWA C105.

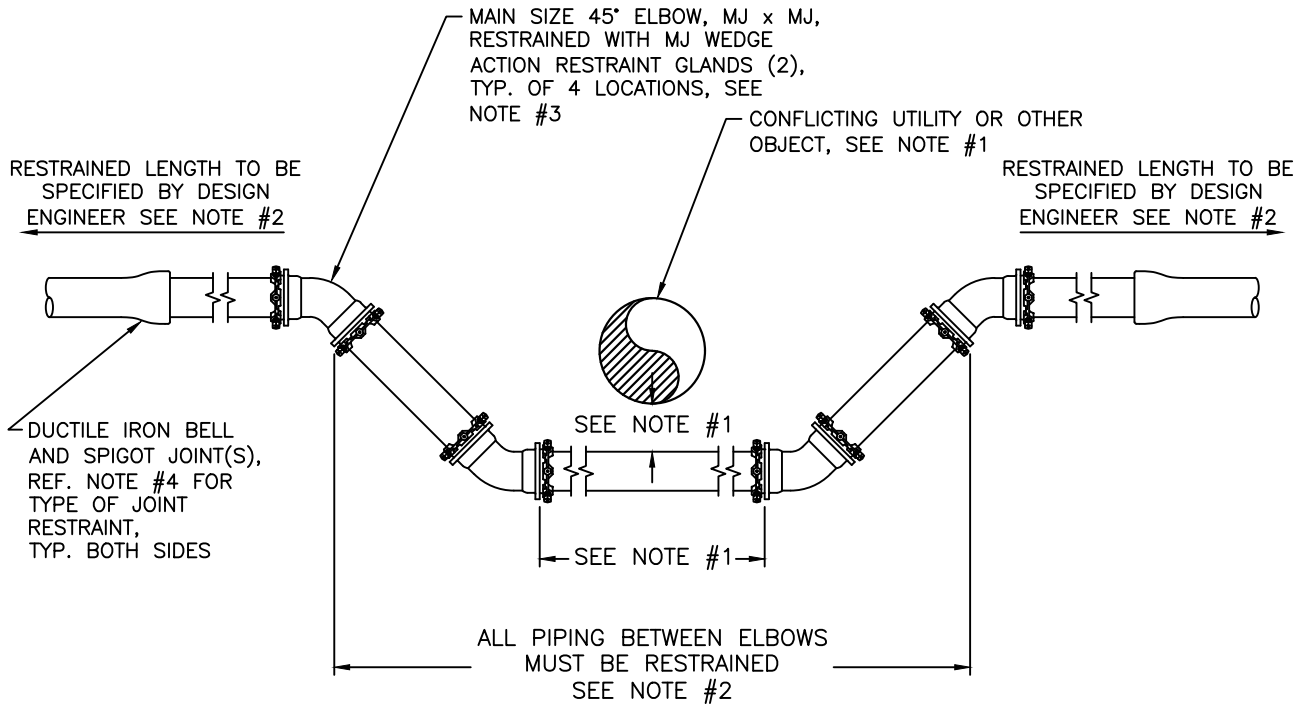

SOURCE: TMWA DETAIL 10I-2



DRAWN: \_\_\_\_\_ NT  
 CHECKED: \_\_\_\_\_ CLR  
 REV: \_\_\_\_\_ MAY 2024  
 REV: \_\_\_\_\_

STANDARD DETAIL

RESTRAINED JOINT VERTICAL  
 OFFSET UNDER UTILITY/OBJECT

WATER

2.9.1

NOTES:

1. REFERENCE DETAILS IN SECTION 2.21 FOR UTILITY SEPARATION REQUIREMENTS.
2. ALL RESTRAINED JOINT PIPING SHALL BE DUCTILE IRON PIPE (RJ-DIP). RESTRAINED LENGTHS OUTSIDE OUTERMOST ELBOWS SHALL BE CALCULATED BY THE DESIGN ENGINEER AND SPECIFIED ON THE WATER IMPROVEMENT PLANS.
3. RESTRAINED JOINT FITTINGS SHALL BE MECHANICAL JOINT (MJ) DUCTILE IRON RESTRAINED WITH MECHANICAL JOINT WEDGE ACTION RESTRAINT GLANDS.
4. BELL AND SPIGOT PUSH-ON JOINTS SHALL BE RESTRAINED USING RUBBER GASKETS WITH STAINLESS STEEL LOCKING SEGMENTS VULCANIZED INTO THE RUBBER GASKET.
5. ALL BOLTS AND EXPOSED METAL SHALL BE COATED WITH BRUSHED-ON MASTIC.
6. FITTINGS, DUCTILE IRON PIPE, AND OTHER METAL PARTS SHALL BE ENCASED WITH POLYETHYLENE WRAP PER AWWA C105.

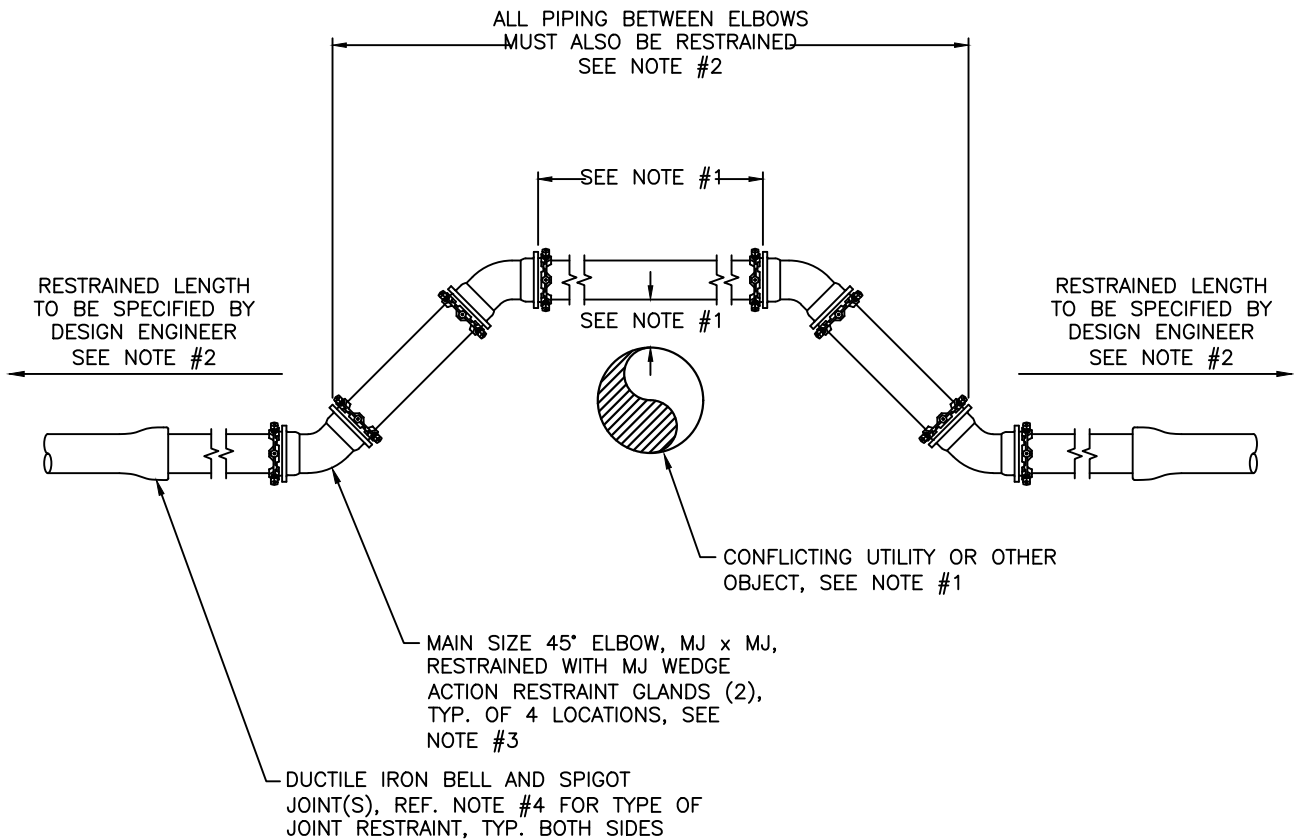

SOURCE: TMWA DETAIL 10I-3



DRAWN: \_\_\_\_\_ NT  
 CHECKED: \_\_\_\_\_ CLR  
 REV: \_\_\_\_\_ MAY 2024  
 REV: \_\_\_\_\_

STANDARD DETAIL

RESTRAINED JOINT VERTICAL  
 OFFSET OVER UTILITY/OBJECT

WATER

2.9.2

NOTES:

1. REFERENCE DETAILS IN SECTION 2.21 FOR UTILITY SEPARATION REQUIREMENTS.
2. ALL RESTRAINED JOINT PIPING SHALL BE DUCTILE IRON PIPE (RJ-DIP). RESTRAINED LENGTHS OUTSIDE OUTERMOST ELBOWS SHALL BE CALCULATED BY THE DESIGN ENGINEER AND SPECIFIED ON THE WATER IMPROVEMENT PLANS.
3. RESTRAINED JOINT FITTINGS SHALL BE MECHANICAL JOINT (MJ) DUCTILE IRON RESTRAINED WITH MECHANICAL JOINT WEDGE ACTION RESTRAINT GLANDS.
4. BELL AND SPIGOT PUSH-ON JOINTS SHALL BE RESTRAINED USING RUBBER GASKETS WITH STAINLESS STEEL LOCKING SEGMENTS VULCANIZED INTO THE RUBBER GASKET.
5. PIPING BETWEEN ELBOWS MUST ALSO BE RESTRAINED.
6. ALL BOLTS AND EXPOSED METAL SHALL BE COATED WITH BRUSHED-ON MASTIC.
7. FITTINGS, DUCTILE IRON PIPE, AND OTHER METAL PARTS SHALL BE ENCASED WITH POLYETHYLENE WRAP PER AWWA C105.

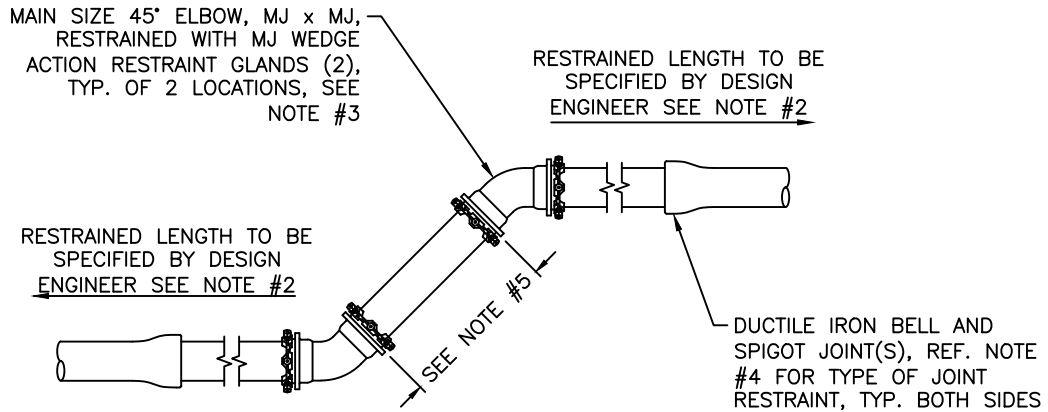

SOURCE: TMWA DETAIL 10I-4



DRAWN: \_\_\_\_\_ NT  
 CHECKED: \_\_\_\_\_ CLR  
 REV: \_\_\_\_\_ MAY 2024  
 REV: \_\_\_\_\_

STANDARD DETAIL

RESTRAINED JOINT SINGLE  
 VERTICAL OFFSET

WATER

2.9.3

**NOTES:**

1. CONCRETE COLLAR SHALL BE MINIMUM 6-INCHES THICK OR MATCH PAVEMENT THICKNESS, WHICHEVER IS GREATER, UNLESS OTHERWISE SPECIFIED BY THE JURISDICTIONAL AGENCY RESPONSIBLE FOR THE ROADWAY.
2. FOR MULTIPLE VALVE/RISER BOXES IN CLOSE PROXIMITY, A MONOLITHIC CONCRETE COLLAR MAY BE POURED.
3. CONTRACTOR AND/OR DESIGN ENGINEER SHALL CONSULT WITH THE JURISDICTIONAL AGENCY RESPONSIBLE FOR THE ROADWAY FOR REQUIREMENTS THAT MAY VARY FROM THIS STANDARD PRIOR TO CONSTRUCTION.
4. ALL BOLTS AND EXPOSED METAL SHALL BE COATED WITH BRUSHED-ON MASTIC.
5. GATE VALVE, DUCTILE IRON PIPE, AND OTHER METAL PARTS SHALL BE ENCASED WITH POLYETHYLENE WRAP PER AWWA C105.
6. UNLESS OTHERWISE SPECIFIED BY THE JURISDICTIONAL AGENCY RESPONSIBLE FOR THE ROADWAY, PORTLAND CEMENT CONCRETE (P.C.C.) FOR CONCRETE COLLAR SHALL HAVE THE FOLLOWING CHARACTERISTICS: 4,000 PSI MINIMUM COMPRESSIVE STRENGTH AT 28 DAYS, MINIMUM 6 SACKS OF CEMENT PER CUBIC YARD WITH A MAXIMUM WATER/CEMENT RATIO OF 0.45, AIR ENTRAINMENT 6% ±1.5%, SLUMP AT 1 TO 4 INCHES. BAG CONCRETE MIX IS NOT ACCEPTABLE.
7. CONCRETE FOR PAD SHALL HAVE A COMPRESSIVE STRENGTH OF NOT LESS THAN 3,000 PSI AFTER 28 DAYS. BAG CONCRETE MIX IS NOT ACCEPTABLE.

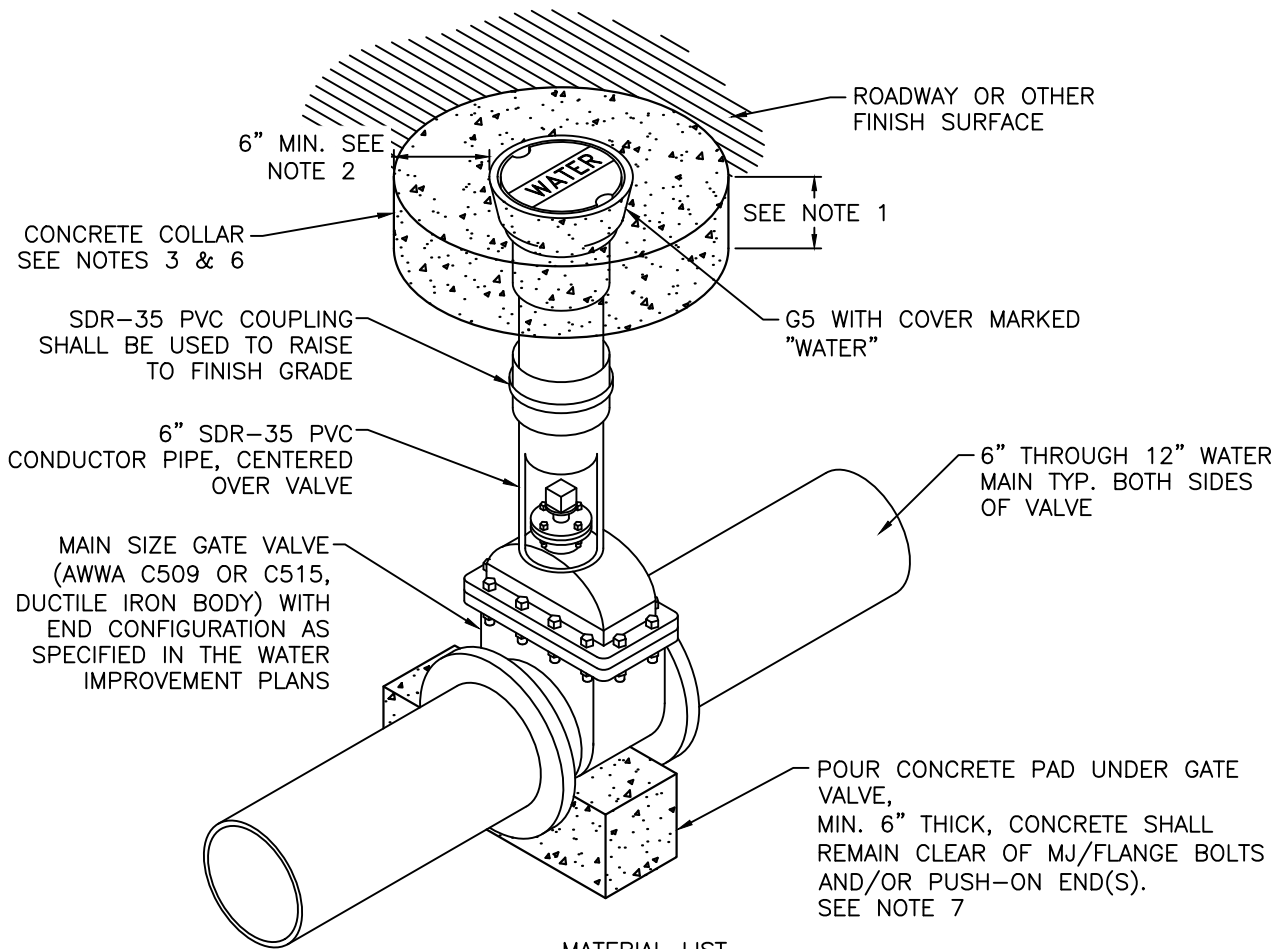

**MATERIAL LIST**

QTY	DESCRIPTION
1	MAIN SIZE GATE VALVE (AWWA C509 OR C515, DUCTILE IRON BODY) WITH END CONFIGURATION AS SPECIFIED IN THE WATER IMPROVEMENT PLANS
1	MASTIC (1 GALLON CAN - BRUSH ON)
1	6" Ø SDR-35 PVC CONDUCTOR PIPE SECTION
1	G5 VALVE BOX WITH COVER MARKED "WATER"
1	FULL FACE GASKET
1	CONCRETE BULK - PAD AND COLLAR

SOURCE: TMWA DETAIL 10J-2

 TRI-GID 440 USA PKWY, SUITE 105 McCARRAN, NEVADA 89437	DRAWN: _____ NT CHECKED: _____ CLR REV: _____ MAY 2024 REV: _____	STANDARD DETAIL <h2 style="margin: 0;">IN-LINE GATE VALVE WITH CONCRETE COLLAR</h2>	WATER <h1 style="margin: 0;">2.10.1</h1>

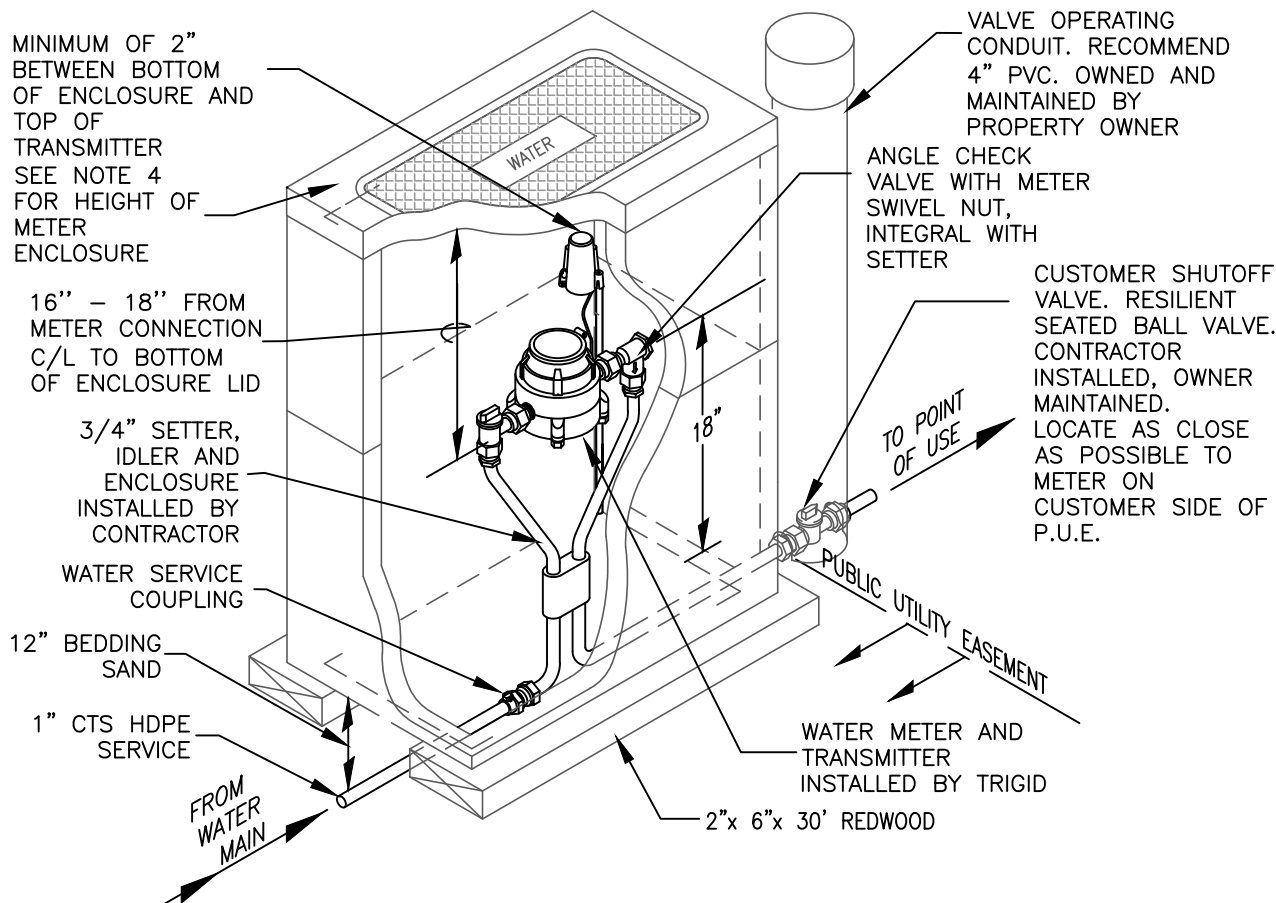

**NOTES:**

1. THERMAL EXPANSION PROTECTION IS REQUIRED IN ANY DOMESTIC WATER SUPPLY SYSTEM THAT IS DOWNSTREAM FROM A BACKFLOW PREVENTION DEVICE. REFERENCE: UNIFORM PLUMBING CODE.
2. METER AND TRANSMITTER SUPPLIED BY CONTRACTOR AND INSTALLED BY TRIGID.
3. FOR DRIVEWAY OR TRAFFIC AREAS USE 13X24 ENCLOSURE APPROVED FOR TRAFFIC RATED H/20 LOADING. SEE DETAIL 2.11.10.
4. TOP OF METER ENCLOSURE SHALL BE SET 0.2 FEET ABOVE HIGHEST FINISHED GRADE SURROUNDING ENCLOSURE WITHIN LANDSCAPED AREAS, AND SHALL BE SET FLUSH WITH SURROUNDING FINISH GRADE IN TRAFFIC AREAS.
5. ENCLOSURE TO BE BACKFILLED WITH WATER PIPE BEDDING SAND ONLY, SEE DETAILS 2.17-2.18.
6. BLANKET TO BE INSTALLED ABOVE METER AND BELOW TRANSMITTER.

**MATERIAL LIST**

ITEM ID	QTY.	DESCRIPTION
MS-CHK-0.75	1.0	SETTER WATER METER, WITH ANGLE CHECK VALVE, NEW 3/4" MIP ENDS
WSC-1.00x0.75-CTSxFIP	1.0	COUPLING SERVICE 1" CTS COMPRESSION X 3/4" FIP
SSL-1.00	1.0	LINER RIGID STAINLESS STEEL FOR 1" CTS HDPE TUBING
GSKT-0.75	2.0	GASKET-3/4" FOR WATER METER
WM-DISC-0.75	1.0	3/4" WATER METER - SUPPLIED AND INSTALLED BY CONTRACTOR
ENCL-12x22-NT	1.0	ENCLOSURE NON-TRAFFIC 12 X 22 WATER METERS, SEE NOTE 3
ENCL-12x22-LID-NT	1.0	COVER NON-TRAFFIC 12 X 22, SEE NOTE 3
ENCL-12x22-EXT-NT	1.0	EXTENSION BOX NON-TRAFFIC 12 X 22, SEE NOTE 3
INSL-BLKT-4x4	1.0	BLANKET INSULATION 4' X 4' FOR WATER METERS
RDWD-BRD-2x6x30	2.0	BOARD - REDWOOD 2" X 6" X 30"
IDLR-0.75	1.0	IDLER WATER METER 3/4" SETTER
ERT	1.0	REMOTE TRANSMITTER - SUPPLIED BY CONTRACTOR AND INSTALLED BY TRIGID

SOURCE: TMWA DETAIL 10K-2

 <p style="font-size: small;">440 USA PKWY, SUITE 105 McCARRAN, NEVADA 89437</p>	DRAWN: _____ NT CHECKED: _____ CLR REV: _____ MAY 2024 REV: _____	STANDARD DETAIL <b>NEW COMMERCIAL INSTALL - 1"          SINGLE SERVICE FOR 3/4" SETTER,          METER, AND TRANSMITTER</b>	WATER  <b>2.11.1</b>
	<b>NEW COMMERCIAL INSTALL - 1"          SINGLE SERVICE FOR 3/4" SETTER,          METER, AND TRANSMITTER</b>		

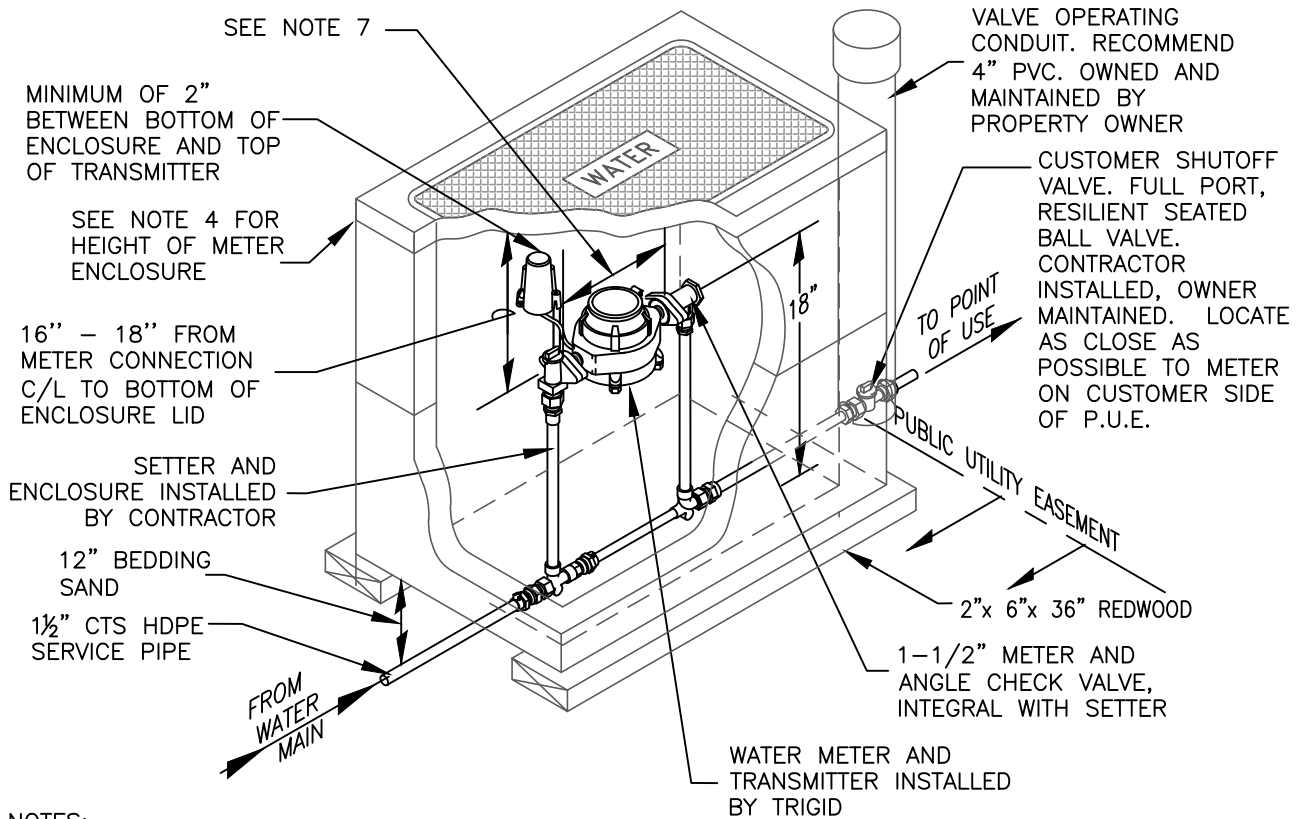

**NOTES:**

1. THERMAL EXPANSION PROTECTION IS REQUIRED IN ANY DOMESTIC WATER SUPPLY SYSTEM THAT IS DOWNSTREAM FROM A BACKFLOW PREVENTION DEVICE. REFERENCE: UNIFORM PLUMBING CODE.
2. METER AND TRANSMITTER SUPPLIED BY CONTRACTOR INSTALLED BY TRIGID.
3. FOR DRIVEWAY OR TRAFFIC AREAS USE 17X30 ENCLOSURE APPROVED FOR TRAFFIC RATED H/20 LOADING. SEE DETAIL 2.11.11.
4. TOP OF METER ENCLOSURE SHALL BE SET 0.2 FEET ABOVE HIGHEST FINISHED GRADE SURROUNDING ENCLOSURE WITHIN LANDSCAPED AREAS, AND SHALL BE SET FLUSH WITH SURROUNDING FINISH GRADE IN TRAFFIC AREAS.
5. ENCLOSURE TO BE BACKFILLED WITH WATER PIPE BEDDING SAND ONLY, SEE DETAILS 2.17-2.18.
6. BLANKET TO BE INSTALLED ABOVE METER AND BELOW TRANSMITTER.
7. DISTANCE BETWEEN FLANGES SHALL BE 13.25".

MATERIAL LIST

ITEM ID	QTY.	DESCRIPTION
MS-CHK-1.50	1.0	SETTER WATER METER, WITH ANGLE CHECK VALVE, NEW 1-1/2" FIP ENDS
WSC-1.50x1.50-CTSxMIP	1.0	COUPLING SERVICE 1-1/2" CTS COMPRESSION X 1-1/2" MIP
SSL-1.50	1.0	LINER RIGID STAINLESS STEEL FOR 1-1/2" CTS HDPE TUBING
GSKT-1.50	2.0	GASKET-1-1/2" FOR WATER METER
WM-DISC-1.50	1.0	1-1/2" WATER METER - SUPPLIED AND INSTALLED BY CONTRACTOR
ENCL-17x30-NT	1.0	ENCLOSURE NON-TRAFFIC 17 X 30 WATER METERS, SEE NOTE 2
ENCL-17x30-LID-NT	1.0	COVER NON-TRAFFIC 17 X 30, NON CONCRETE FIBRELYTE LID, SEE NOTE 2
ENCL-17x30-EXT-NT	1.0	EXTENSION BOX NON-TRAFFIC 17 X 30, SEE NOTE 2
INSL-BLKT-4x4	1.0	BLANKET INSULATION 4' X 4' FOR WATER METERS
RDWD-BRD-2X6X36	2.0	BOARD - REDWOOD 2" X 6" X 36"
IDLR-1.50	1.0	IDLER WATER METER 1-1/2" SETTER
BOLTS	4.0	BOLT COPPER #651 SILICONE BRONZE 5/8" X 2-1/2" WITH 2 FLAT WASHERS & NUTS
ERT	1.0	REMOTE TRANSMITTER - SUPPLIED BY CONTRACTOR AND INSTALLED BY TRIGID

SOURCE: TMWA DETAIL 10K-4



DRAWN: \_\_\_\_\_ NT  
 CHECKED: \_\_\_\_\_ CLR  
 REV: \_\_\_\_\_ MAY 2024  
 REV: \_\_\_\_\_

STANDARD DETAIL

**NEW COMMERCIAL INSTALL - 1 1/2"  
 SINGLE SERVICE FOR 1/2" SETTER,  
 METER, AND TRANSMITTER**

WATER

**2.11.2**

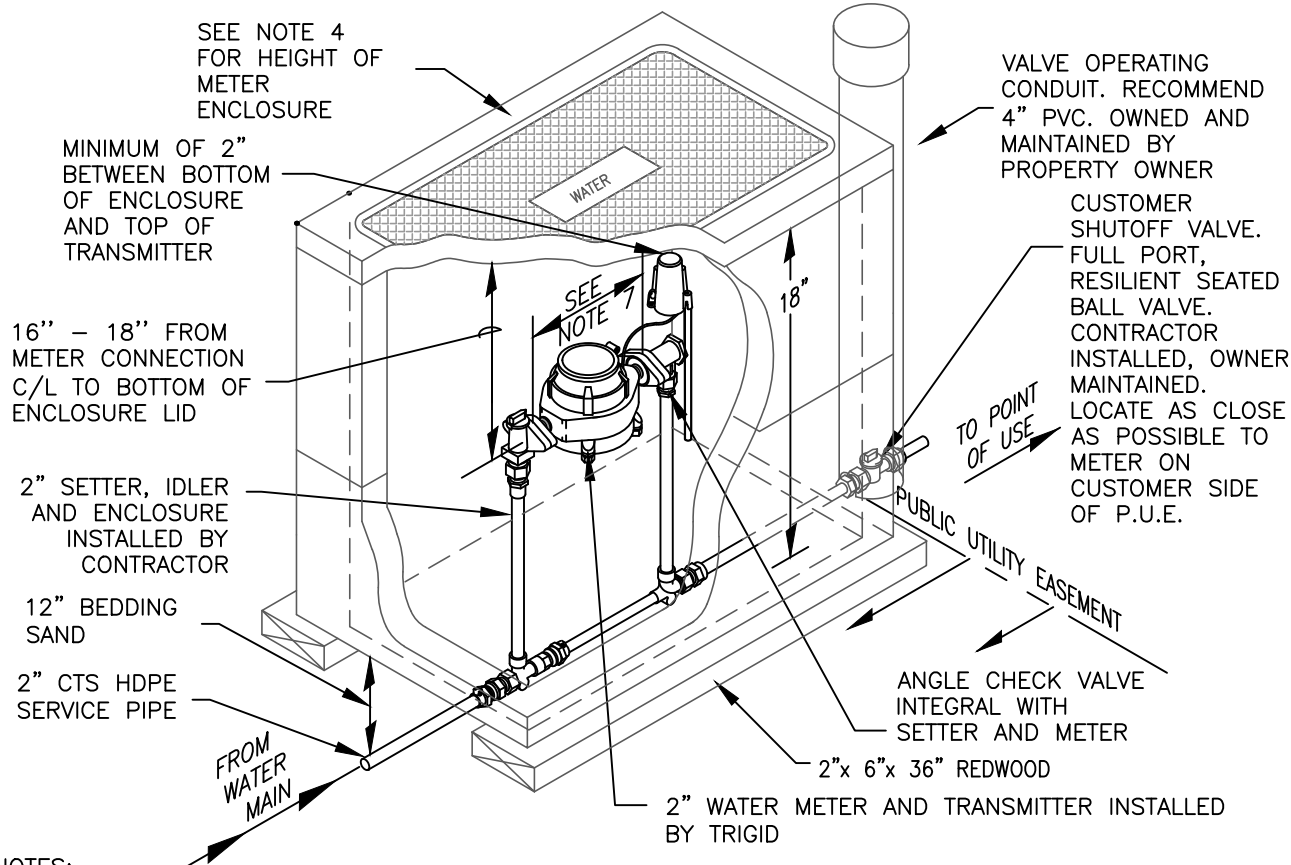

**NOTES:**

1. THERMAL EXPANSION PROTECTION IS REQUIRED IN ANY DOMESTIC WATER SUPPLY SYSTEM THAT IS DOWNSTREAM FROM A BACKFLOW PREVENTION DEVICE. REFERENCE: UNIFORM PLUMBING CODE.
2. METER AND TRANSMITTER SUPPLIED BY CONTRACTOR AND INSTALLED BY TRIGID.
3. FOR DRIVEWAY OR TRAFFIC AREAS USE 17X30 ENCLOSURE APPROVED FOR TRAFFIC RATED H/20 LOADING. SEE DETAIL 2.11.11.
4. TOP OF METER ENCLOSURE SHALL BE SET 0.2 FEET ABOVE HIGHEST FINISHED GRADE SURROUNDING ENCLOSURE WITHIN LANDSCAPED AREAS, AND SHALL BE SET FLUSH WITH SURROUNDING FINISH GRADE IN TRAFFIC AREAS.
5. ENCLOSURE TO BE BACKFILLED WITH WATER PIPE BEDDING SAND ONLY, SEE DETAILS 2.17-2.18.
6. BLANKET TO BE INSTALLED ABOVE METER AND BELOW TRANSMITTER.
7. DISTANCE BETWEEN FLANGES SHALL BE 17.25".

**MATERIAL LIST**

ITEM ID	QTY.	DESCRIPTION
MS-CHK-2.00	1.0	SETTER WATER METER, WITH ANGLE CHECK VALVE, NEW 2" FIP ENDS
WSC-2.00x2.00-CTSxMIP	1.0	COUPLING SERVICE 2" CTS COMPRESSION X 2" MIP
SSL-2.00	1.0	LINER RIGID STAINLESS STEEL FOR 2" CTS HDPE TUBING
GSKT-2.00	2.0	GASKET-2" FOR WATER METER
WM-DISC-2.00	1.0	2" WATER METER - SUPPLIED AND INSTALLED BY CONTRACTOR
ENCL-17x30-NT	1.0	ENCLOSURE NON-TRAFFIC 17 X 30 WATER METERS, SEE NOTE 3
ENCL-17x30-LID-NT	1.0	COVER NON-TRAFFIC 17 X 30, NON CONCRETE FIBRELYTE LID, SEE NOTE 3
ENCL-17x30-EXT-NT	1.0	EXTENSION BOX NON-TRAFFIC 17 X 30, SEE NOTE 3
INSL-BLKT-4x4	1.0	BLANKET INSULATION 4' X 4' FOR WATER METERS
RDWD-BRD-2X6X36	2.0	BOARD - REDWOOD 2" X 6" X 36"
IDLR-2.00	1.0	IDLER WATER METER 2" SETTER
BOLTS	4.0	BOLT COPPER #651 SILICONE BRONZE 5/8" X 2-1/2" WITH 2 FLAT WASHERS & NUTS
ERT	1.0	REMOTE TRANSMITTER - SUPPLIED BY CONTRACTOR AND INSTALLED BY TRIGID

SOURCE: TMWA DETAIL 10K-5

 440 USA PKWY, SUITE 105 McCARRAN, NEVADA 89437	DRAWN: _____ NT CHECKED: _____ CLR REV: _____ MAY 2024 REV: _____	STANDARD DETAIL <b>NEW COMMERCIAL INSTALL - 2"          SINGLE SERVICE FOR 2" SETTER,          METER, AND TRANSMITTER</b>	WATER  <b>2.11.3</b>



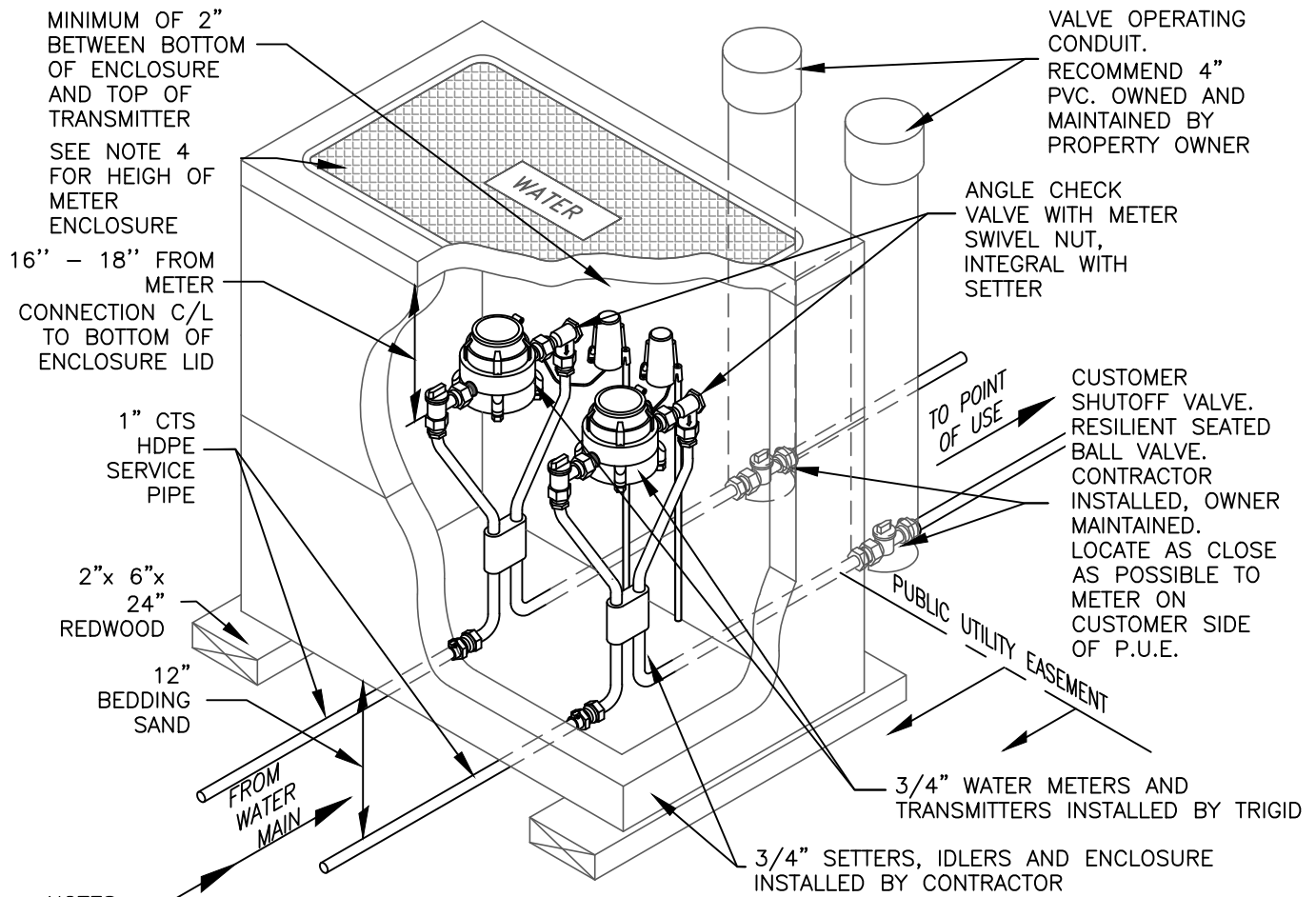

**NOTES:**

1. THERMAL EXPANSION PROTECTION IS REQUIRED IN ANY DOMESTIC WATER SUPPLY SYSTEM THAT IS DOWNSTREAM FROM A BACKFLOW PREVENTION DEVICE. REFERENCE: UNIFORM PLUMBING CODE.
2. METER AND TRANSMITTER SUPPLIED BY CONTRACTOR AND INSTALLED BY TRIGID.
3. FOR DRIVEWAY OR TRAFFIC AREAS USE 17X30 ENCLOSURE APPROVED FOR TRAFFIC RATED H/20 LOADING. SEE DETAIL 2.11.11.
4. TOP OF METER ENCLOSURE SHALL BE SET 0.2 FEET ABOVE HIGHEST FINISHED GRADE SURROUNDING ENCLOSURE WITHIN LANDSCAPED AREAS, AND SHALL BE SET FLUSH WITH SURROUNDING FINISH GRADE IN TRAFFIC AREAS.
5. ENCLOSURE TO BE BACKFILLED WITH WATER PIPE BEDDING SAND ONLY, SEE DETAILS 2.17-2.18.
6. BLANKET TO BE INSTALLED ABOVE METER AND BELOW TRANSMITTER.

**MATERIAL LIST**

ITEM ID	QTY.	DESCRIPTION
MS-CHK-0.75	2.0	SETTER WATER METER, WITH ANGLE CHECK VALVE, NEW 3/4" MIP ENDS
WSC-1.00x0.75-CTSxFIP	2.0	COUPLING SERVICE 1" CTS COMPRESSION X 3/4" FIP
SSL-1.00	2.0	LINER RIGID STAINLESS STEEL FOR 1" CTS HDPE TUBING
GSKT-0.75	4.0	GASKET-3/4" FOR WATER METER
WM-DISC-0.75	2.0	3/4" WATER METER - SUPPLIED AND INSTALLED BY CONTRACTOR
ENCL-17x30-NT	1.0	ENCLOSURE NON-TRAFFIC 17 X 30 WATER METERS, SEE NOTE 3
ENCL-17x30-LID-NT	1.0	COVER NON-TRAFFIC 17 X 30, NON CONCRETE FIBRELYTE LID, SEE NOTE 3
ENCL-17x30-EXT-NT	1.0	EXTENSION BOX NON-TRAFFIC 17 X 30, SEE NOTE 3
INSL-BLKT-4x4	1.0	BLANKET INSULATION 4' X 4' FOR WATER METERS
RDWD-BRD-2x6x24	2.0	BOARD - REDWOOD 2" X 6" X 24"
IDLR-0.75	2.0	IDLER WATER METER 3/4" SETTER
ERT	2.0	REMOTE TRANSMITTER - SUPPLIED BY CONTRACTOR AND INSTALLED BY TRIGID

SOURCE: TMWA DETAIL 10K-6

 440 USA PKWY, SUITE 105 McCARRAN, NEVADA 89437	DRAWN: _____ NT CHECKED: _____ CLR REV: _____ MAY 2024 REV: _____	STANDARD DETAIL  <b>NEW COMMERCIAL INSTALL - 1"          DUAL SERVICE FOR 3/4" SETTER,          METER, AND TRANSMITTER</b>	WATER  <b>2.11.4</b>



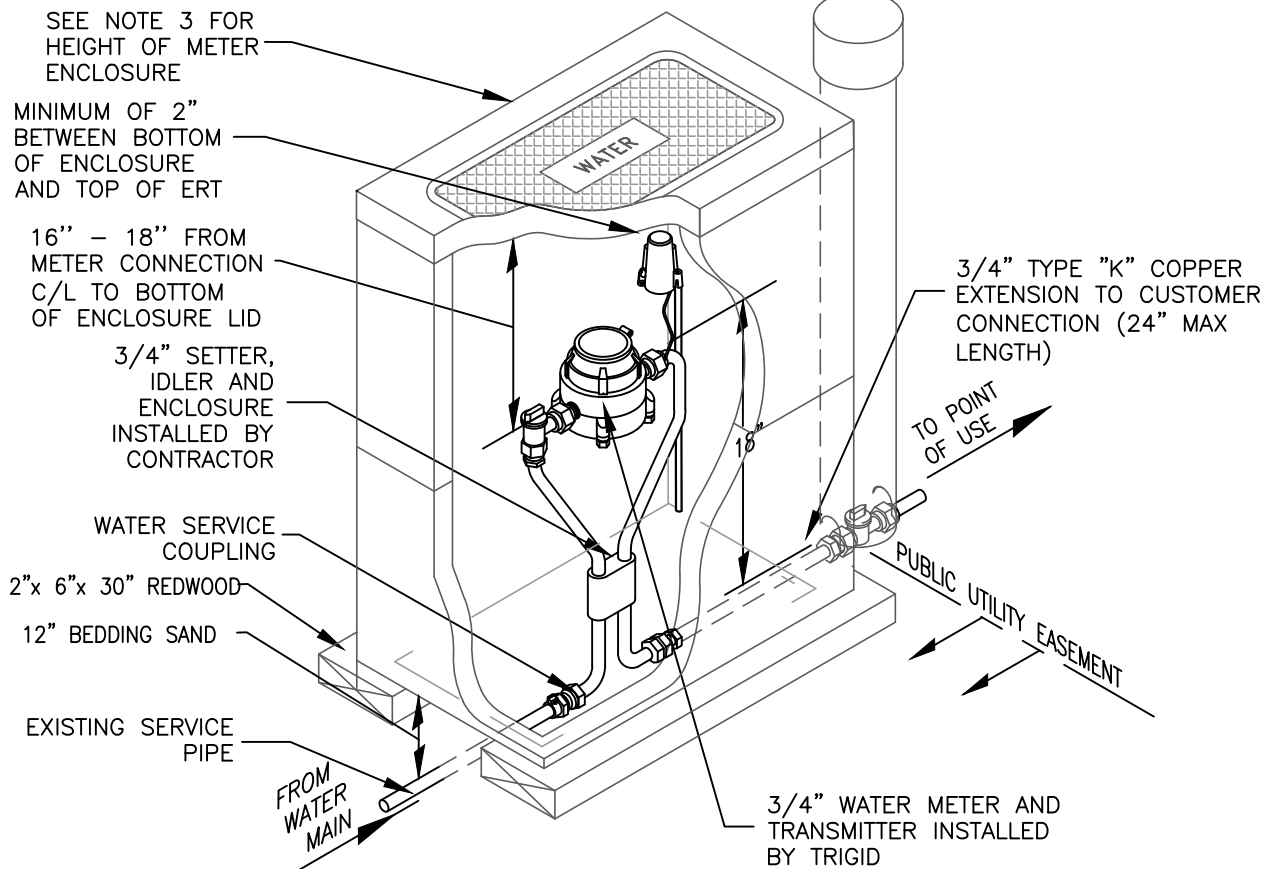

**NOTES:**

1. METER AND TRANSMITTER SUPPLIED BY CONTRACTOR AND INSTALLED BY TRIGID.
2. FOR DRIVEWAY OR TRAFFIC AREAS USE 13X24 ENCLOSURE APPROVED FOR TRAFFIC RATED H/20 LOADING. SEE DETAIL 2.11.10.
3. TOP OF METER ENCLOSURE SHALL BE SET 0.2 FEET ABOVE HIGHEST FINISHED GRADE SURROUNDING ENCLOSURE WITHIN LANDSCAPED AREAS, AND SHALL BE SET FLUSH WITH SURROUNDING FINISH GRADE IN TRAFFIC AREAS.
4. ENCLOSURE TO BE BACKFILLED WITH WATER PIPE BEDDING SAND ONLY, SEE DETAILS 2.17-2.18.
5. BLANKET TO BE INSTALLED ABOVE METER AND BELOW TRANSMITTER.
6. IF SERVICE LINE IS IRON PIPE, GALVANIZED OR BARE STEEL, INSTALL A DIELECTRIC UNION ON THE SETTER. USE A MALE ADAPTER TO CONNECT THE SERVICE LINE. COAT THE ADAPTER AND ONE FOOT OF SERVICE LINE WITH MASTIC.

**MATERIAL LIST**

ITEM ID	QTY.	DESCRIPTION
MS-0.75-RETRO	1.0	SETTER WATER METER
-	1.0	COUPLING SERVICE - BASED ON EXISTING SERVICE X 3/4" FIP
SSL-1.00	1.0	LINER RIGID STAINLESS STEEL FOR 1" CTS HDPE TUBING
GSKT-0.75	2.0	GASKET-3/4" FOR WATER METER
WM-DISC-0.75	1.0	3/4" WATER METER - SUPPLIED AND INSTALLED BY CONTRACTOR
ENCL-12x22-NT	1.0	ENCLOSURE NON-TRAFFIC 12 X 22 WATER METERS, SEE NOTE 2
ENCL-12x22-LID-NT	1.0	COVER NON-TRAFFIC 12 X 22, SEE NOTE 2
ENCL-12x22-EXT-NT	1.0	EXTENSION BOX NON-TRAFFIC 12 X 22, SEE NOTE 2
INSL-BLKT-4x4	1.0	BLANKET INSULATION 4' X 4' FOR WATER METERS
RDWD-BRD-2x6x30	2.0	BOARD - REDWOOD 2" X 6" X 30"
IDLR-0.75	1.0	IDLER WATER METER 3/4" SETTER
ERT	1.0	REMOTE TRANSMITTER - SUPPLIED BY CONTRACTOR AND INSTALLED BY TRIGID

SOURCE: TMWA DETAIL 10K-12

 440 USA PKWY, SUITE 105 McCARRAN, NEVADA 89437	DRAWN: _____ NT CHECKED: _____ CLR REV: _____ MAY 2024 REV: _____	STANDARD DETAIL <b>RETROFIT INSTALL - 1" SINGLE          SERVICE FOR 3/4" SETTER, METER,          AND TRANSMITTER</b>	WATER  <b>2.11.5</b>

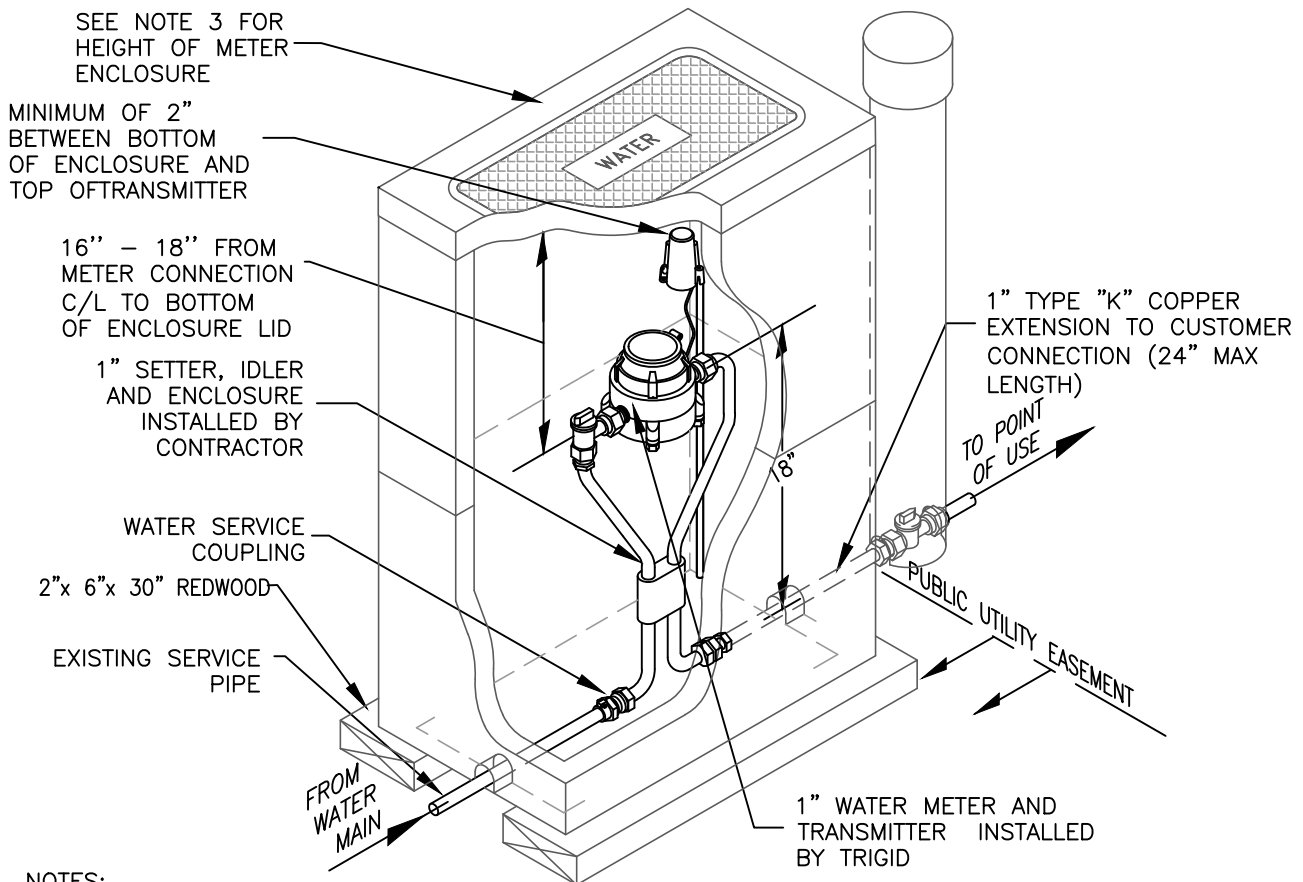

**NOTES:**

1. METER AND TRANSMITTER SUPPLIED BY CONTRACTOR AND INSTALLED BY TRIGID.
2. FOR DRIVEWAY OR TRAFFIC AREAS USE 13X24 ENCLOSURE APPROVED FOR TRAFFIC RATED H/20 LOADING. SEE DETAIL 2.11.10.
3. TOP OF METER ENCLOSURE SHALL BE SET 0.2 FEET ABOVE HIGHEST FINISHED GRADE SURROUNDING ENCLOSURE WITHIN LANDSCAPED AREAS, AND SHALL BE SET FLUSH WITH SURROUNDING FINISH GRADE IN TRAFFIC AREAS.
4. ENCLOSURE TO BE BACKFILLED WITH WATER PIPE BEDDING SAND ONLY, SEE DETAILS 2.17-2.18.
5. BLANKET TO BE INSTALLED ABOVE METER AND BELOW TRANSMITTER.
6. IF SERVICE LINE IS IRON PIPE, GALVANIZED OR BARE STEEL, INSTALL A DIELECTRIC UNION ON THE SETTER. USE A MALE ADAPTER TO CONNECT THE SERVICE LINE. COAT THE ADAPTER AND ONE FOOT OF SERVICE LINE WITH MASTIC.

MATERIAL LIST

ITEM ID	QTY.	DESCRIPTION
MS-1.00-RETRO	1.0	SETTER WATER METER
-	1.0	COUPLING SERVICE - BASED ON EXISTING SERVICE X 1" FIP
SSL-1.25	1.0	LINER RIGID STAINLESS STEEL FOR 1-1/4" CTS HDPE TUBING
GSKT-1.00	2.0	GASKET-1" FOR WATER METER
WM-DISC-1.00	1.0	1" WATER METER - SUPPLIED AND INSTALLED BY CONTRACTOR
ENCL-13x24-NT	1.0	ENCLOSURE NON-TRAFFIC 13 X 24 WATER METERS, SEE NOTE 2
ENCL-13 X 24-LID-NT	1.0	COVER NON-TRAFFIC 13 X 24, SEE NOTE 2
ENCL-13 X 24-EXT-NT	1.0	EXTENSION BOX NON-TRAFFIC 13 X 24, SEE NOTE 2
INSL-BLKT-4x4	1.0	BLANKET INSULATION 4' X 4' FOR WATER METERS
RDWD-BRD-2x6x30	2.0	BOARD - REDWOOD 2" X 6" X 30"
IDLR-1.00	1.0	IDLER WATER METER 1" SETTER
ERT	1.0	REMOTE TRANSMITTER - SUPPLIED BY CONTRACTOR AND INSTALLED BY TRIGID

SOURCE: TMWA DETAIL 10K-13

 440 USA PKWY, SUITE 105 McCARRAN, NEVADA 89437	DRAWN: _____ NT CHECKED: _____ CLR REV: _____ MAY 2024 REV: _____	STANDARD DETAIL  <b>RETROFIT INSTALL - 1/4" SINGLE          SERVICE FOR 1" SETTER, METER,          AND TRANSMITTER</b>	WATER  <b>2.11.6</b>

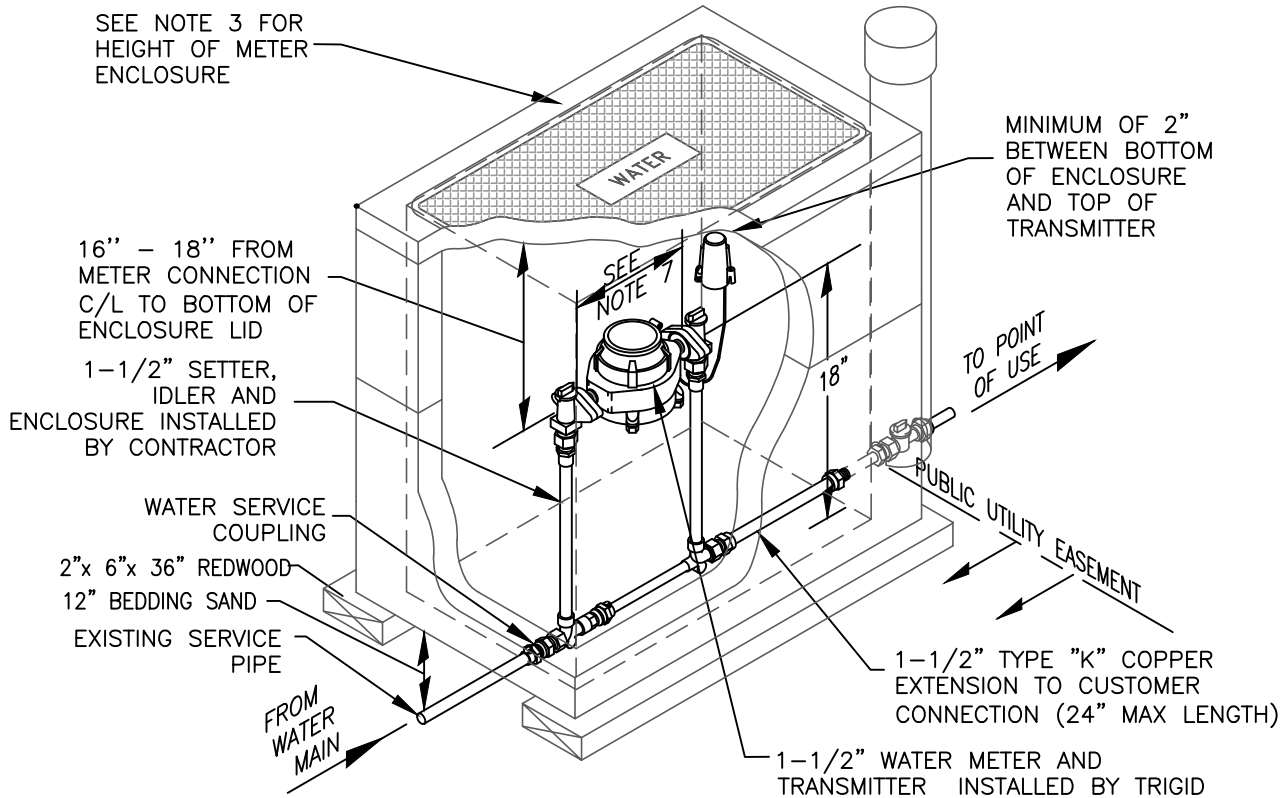

**NOTES:**

1. METER AND TRANSMITTER SUPPLIED BY CONTRACTOR AND INSTALLED BY TRIGID.
2. FOR DRIVEWAY OR TRAFFIC AREAS USE 17X30 ENCLOSURE APPROVED FOR TRAFFIC RATED H/20 LOADING. SEE DETAIL 2.11.11.
3. TOP OF METER ENCLOSURE SHALL BE SET 0.2 FEET ABOVE HIGHEST FINISHED GRADE SURROUNDING ENCLOSURE WITHIN LANDSCAPED AREAS, AND SHALL BE SET FLUSH WITH SURROUNDING FINISH GRADE IN TRAFFIC AREAS.
4. ENCLOSURE TO BE BACKFILLED WITH WATER PIPE BEDDING SAND ONLY, SEE DETAILS 2.17-2.18.
5. BLANKET TO BE INSTALLED ABOVE METER AND BELOW TRANSMITTER.
6. IF SERVICE LINE IS IRON PIPE, GALVANIZED OR BARE STEEL, INSTALL A DIELECTRIC UNION ON THE SETTER. USE A MAKE ADAPTER TO CONNECT THE SERVICE LINE. COAT THE ADAPTER AND ONE FOOT OF SERVICE LINE WITH MASTIC.
7. DISTANCE BETWEEN FLANGES SHALL BE 13.25".

MATERIAL LIST

ITEM ID	QTY.	DESCRIPTION
MS-1.50-RETRO	1.0	SETTER WATER METER
-	1.0	COUPLING SERVICE - BASED ON EXISTING SERVICE X 1-1/2" MIP
SSL-1.50	1.0	LINER RIGID STAINLESS STEEL FOR 1-1/2" CTS HDPE TUBING
GSKT-1.50	2.0	GASKET-1-1/2" FOR WATER METER
WM-DISC-1.50	1.0	1-1/2" WATER METER - SUPPLIED AND INSTALLED BY CONTRACTOR
ENCL-17x30-NT	1.0	ENCLOSURE NON-TRAFFIC 17 X 30 WATER METERS, SEE NOTE 2
ENCL-17x30-LID-NT	1.0	COVER NON-TRAFFIC 17 X 30, NON CONCRETE FIBRELYTE LID, SEE NOTE 2
ENCL-17x30-EXT-NT	1.0	EXTENSION BOX NON-TRAFFIC 17 X 30, SEE NOTE 2
INSL-BLKT-4x4	1.0	BLANKET INSULATION 4' X 4' FOR WATER METERS
RDWD-BRD-2X6X36	2.0	BOARD - REDWOOD 2" X 6" X 36"
IDLR-1.50	1.0	IDLER WATER METER 1-1/2" SETTER
BOLTS	4.0	BOLT COPPER #651 SILICONE BRONZE 5/8" X 2-1/2" WITH 2 FLAT WASHERS & NUTS
ERT	1.0	REMOTE TRANSMITTER - SUPPLIED BY CONTRACTOR AND INSTALLED BY TRIGID

SOURCE: TMWA DETAIL 10K-14

 440 USA PKWY, SUITE 105 McCARRAN, NEVADA 89437	DRAWN: _____ NT CHECKED: _____ CLR REV: _____ MAY 2024 REV: _____	STANDARD DETAIL <b>NEW COMMERCIAL INSTALL - 2"          SINGLE SERVICE FOR 2" SETTER,          METER, AND TRANSMITTER</b>	WATER  <b>2.11.7</b>
	<b>NEW COMMERCIAL INSTALL - 2"          SINGLE SERVICE FOR 2" SETTER,          METER, AND TRANSMITTER</b>		

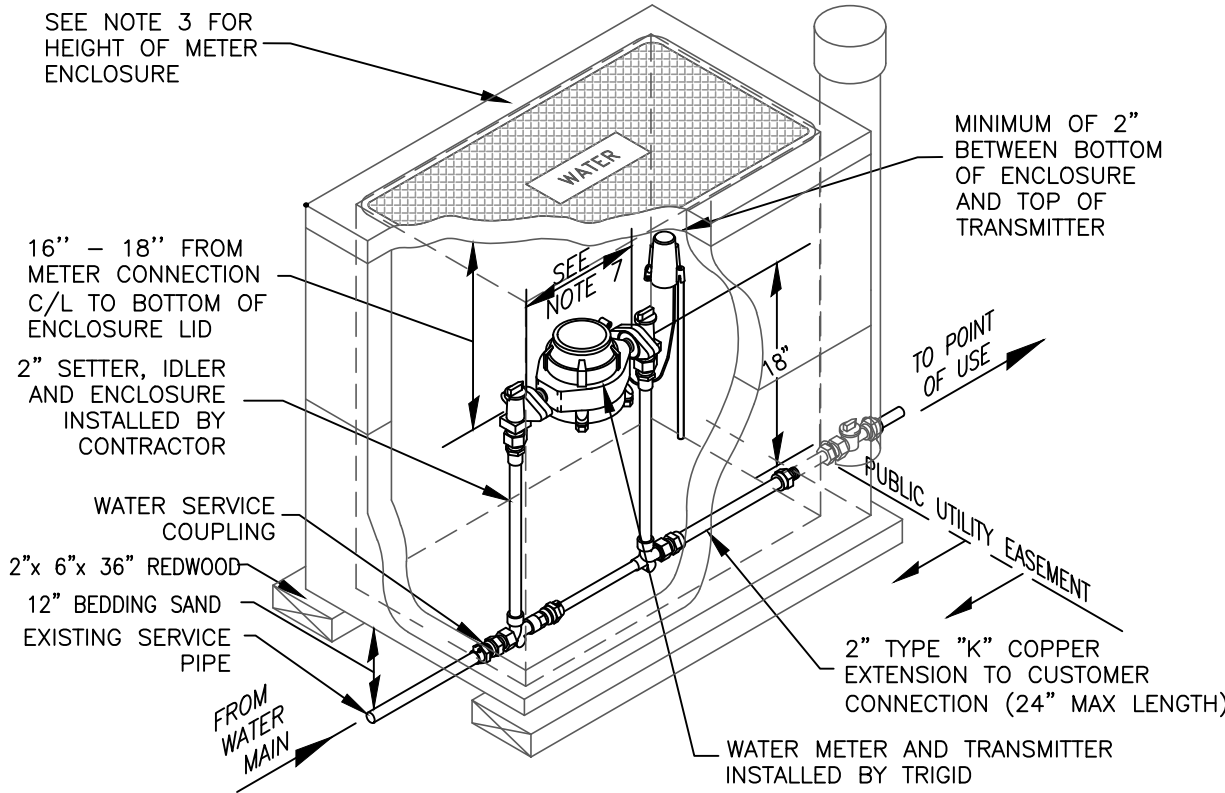

**NOTES:**

1. METER AND TRANSMITTER SUPPLIED BY CONTRACTOR AND INSTALLED BY TRIGID.
2. FOR DRIVEWAY OR TRAFFIC AREAS USE 17X30 ENCLOSURE APPROVED FOR TRAFFIC RATED H/20 LOADING. SEE DETAIL 2.11.11.
3. TOP OF METER ENCLOSURE SHALL BE SET 0.2 FEET ABOVE HIGHEST FINISHED GRADE SURROUNDING ENCLOSURE WITHIN LANDSCAPED AREAS, AND SHALL BE SET FLUSH WITH SURROUNDING FINISH GRADE IN TRAFFIC AREAS.
4. ENCLOSURE TO BE BACKFILLED WITH WATER PIPE BEDDING SAND ONLY, SEE DETAILS 2.17-2.18.
5. BLANKET TO BE INSTALLED ABOVE METER AND BELOW TRANSMITTER.
6. IF SERVICE LINE IS IRON PIPE, GALVANIZED OR BARE STEEL, INSTALL A DIELECTRIC UNION ON THE SETTER. USE A MALE ADAPTER TO CONNECT THE SERVICE LINE. COAT THE ADAPTER AND ONE FOOT OF SERVICE LINE WITH MASTIC.
7. DISTANCE BETWEEN FLANGES SHALL BE 17.25".

**MATERIAL LIST**

ITEM ID	QTY.	DESCRIPTION
MS-2.00-RETRO	1.0	SETTER WATER METER
-	1.0	COUPLING SERVICE - BASED ON EXISTING SERVICE X 2" MIP
SSL-2.00	1.0	LINER RIGID STAINLESS STEEL FOR 2" CTS HDPE TUBING
GSKT-2.00	2.0	GASKET- 2" FOR WATER METER
WM-DISC-2.00	1.0	2" WATER METER - SUPPLIED AND INSTALLED BY CONTRACTOR
ENCL-17x30-NT	1.0	ENCLOSURE NON-TRAFFIC 17 X 30 WATER METERS, SEE NOTE 2
ENCL-17x30-LID-NT	1.0	COVER NON-TRAFFIC 17 X 30, NON CONCRETE FIBRELYTE LID, SEE NOTE 2
ENCL-17x30-EXT-NT	1.0	EXTENSION BOX NON-TRAFFIC 17 X 30, SEE NOTE 2
INSL-BLKT-4x4	1.0	BLANKET INSULATION 4' X 4' FOR WATER METERS
RDWD-BRD-2X6X36	2.0	BOARD - REDWOOD 2" X 6" X 36"
IDLR-2.00	1.0	IDLER WATER METER 2" SETTER
BOLTS	4.0	BOLT COPPER #651 SILICONE BRONZE 5/8" X 2-1/2" WITH 2 FLAT WASHERS & NUTS
ERT	1.0	REMOTE TRANSMITTER - SUPPLIED BY CONTRACTOR AND INSTALLED BY TRIGID

SOURCE: TMWA DETAIL 10K-15



DRAWN: \_\_\_\_\_ NT  
 CHECKED: \_\_\_\_\_ CLR  
 REV: \_\_\_\_\_ MAY 2024  
 REV: \_\_\_\_\_

STANDARD DETAIL

**RETROFIT INSTALL - 2" SINGLE SERVICE FOR 2" SETTER, METER, AND TRANSMITTER**

WATER

2.11.8

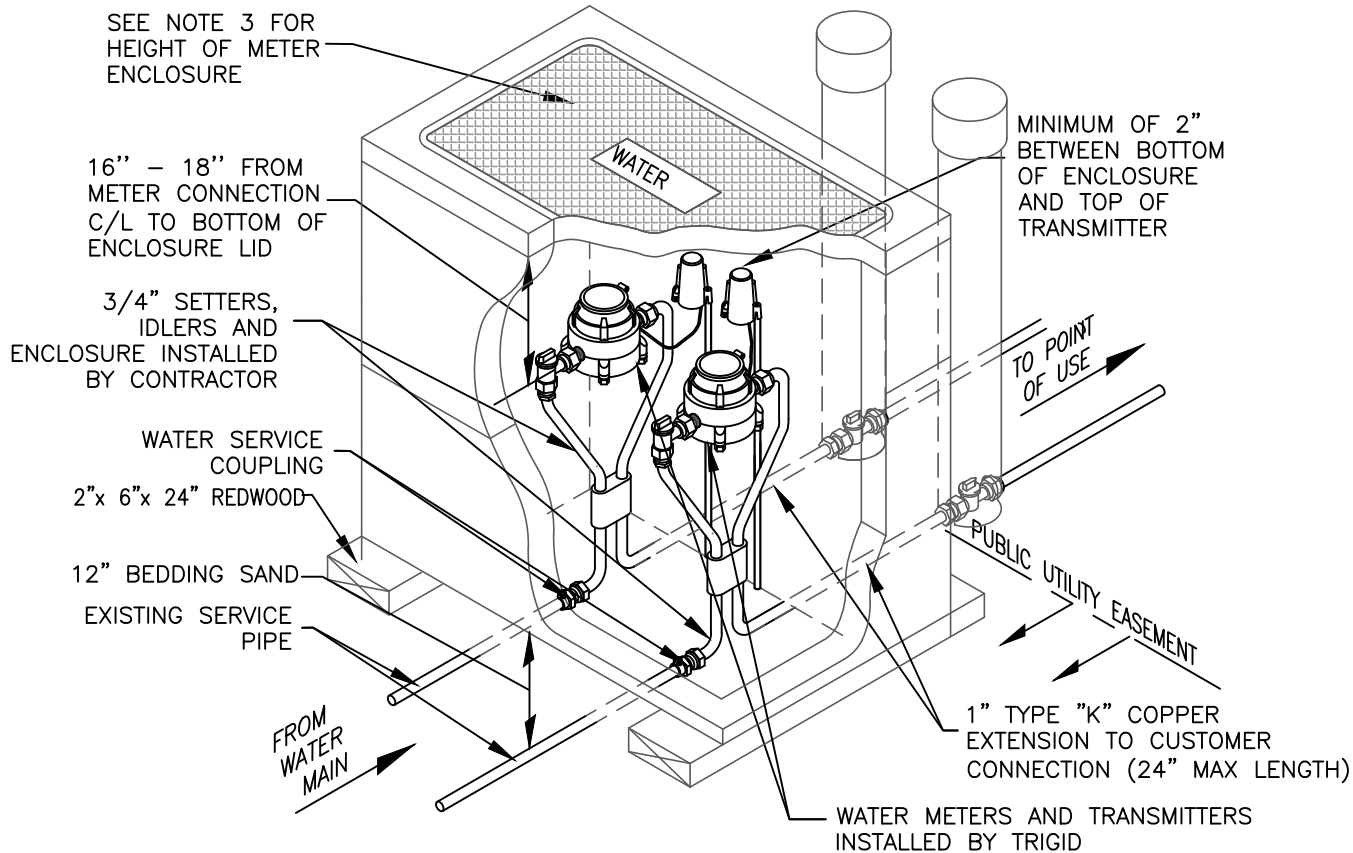

**NOTES:**

1. METER AND TRANSMITTER SUPPLIED BY CONTRACTOR AND INSTALLED BY TRIGID.
2. FOR DRIVEWAY OR TRAFFIC AREAS USE 17X30 ENCLOSURE APPROVED FOR TRAFFIC RATED H/20 LOADING. SEE DETAIL 2.11.11.
3. TOP OF METER ENCLOSURE SHALL BE SET 0.2 FEET ABOVE HIGHEST FINISHED GRADE SURROUNDING ENCLOSURE WITHIN LANDSCAPED AREAS, AND SHALL BE SET FLUSH WITH SURROUNDING FINISH GRADE IN TRAFFIC AREAS.
4. ENCLOSURE TO BE BACKFILLED WITH WATER PIPE BEDDING SAND ONLY, SEE DETAILS 2.17-2.18.
5. BLANKET TO BE INSTALLED ABOVE METER AND BELOW TRANSMITTER.
6. IF SERVICE LINE IS IRON PIPE, GALVANIZED OR BARE STEEL, INSTALL A DIELECTRIC UNION ON THE SETTER. USE A MALE ADAPTER TO CONNECT THE SERVICE LINE. COAT THE ADAPTER AND ONE FOOT OF SERVICE LINE WITH MASTIC.

**MATERIAL LIST**

ITEM ID	QTY.	DESCRIPTION
MS-0.75-RETRO	2.0	SETTER WATER METER
-	2.0	COUPLING SERVICE 1" CTS COMPRESSION X 3/4" FIP
SSL-1.00	2.0	LINER RIGID STAINLESS STEEL FOR 1" CTS HDPE TUBING
GSKT-0.75	4.0	GASKET-3/4" FOR WATER METER
WM-DISC-0.75	2.0	3/4" WATER METER - SUPPLIED AND INSTALLED BY CONTRACTOR
ENCL-17x30-NT	1.0	ENCLOSURE NON-TRAFFIC 17 X 30 WATER METERS, SEE NOTE 2
ENCL-17x30-LID-NT	1.0	COVER NON-TRAFFIC 17 X 30, NON CONCRETE FIBRELYTE LID, SEE NOTE 2
ENCL-17x30-EXT-NT	1.0	EXTENSION BOX NON-TRAFFIC 17 X 30, SEE NOTE 2
INSL-BLKT-4x4	1.0	BLANKET INSULATION 4' X 4' FOR WATER METERS
RDWD-BRD-2x6x24	2.0	BOARD - REDWOOD 2" X 6" X 24"
IDLR-0.75	2.0	IDLER WATER METER 3/4" SETTER
ERT	2.0	REMOTE TRANSMITTER - SUPPLIED BY CONTRACTOR AND INSTALLED BY TRIGID

SOURCE: TMWA DETAIL 10K-16

 TRI-GID 440 USA PKWY, SUITE 105 McCARRAN, NEVADA 89437	DRAWN: _____ NT CHECKED: _____ CLR REV: _____ MAY 2024 REV: _____	STANDARD DETAIL <b>RETROFIT INSTALL - 1" DUAL          SERVICE FOR 3/4" SETTER, METER,          AND TRANSMITTER</b>	WATER  <b>2.11.9</b>

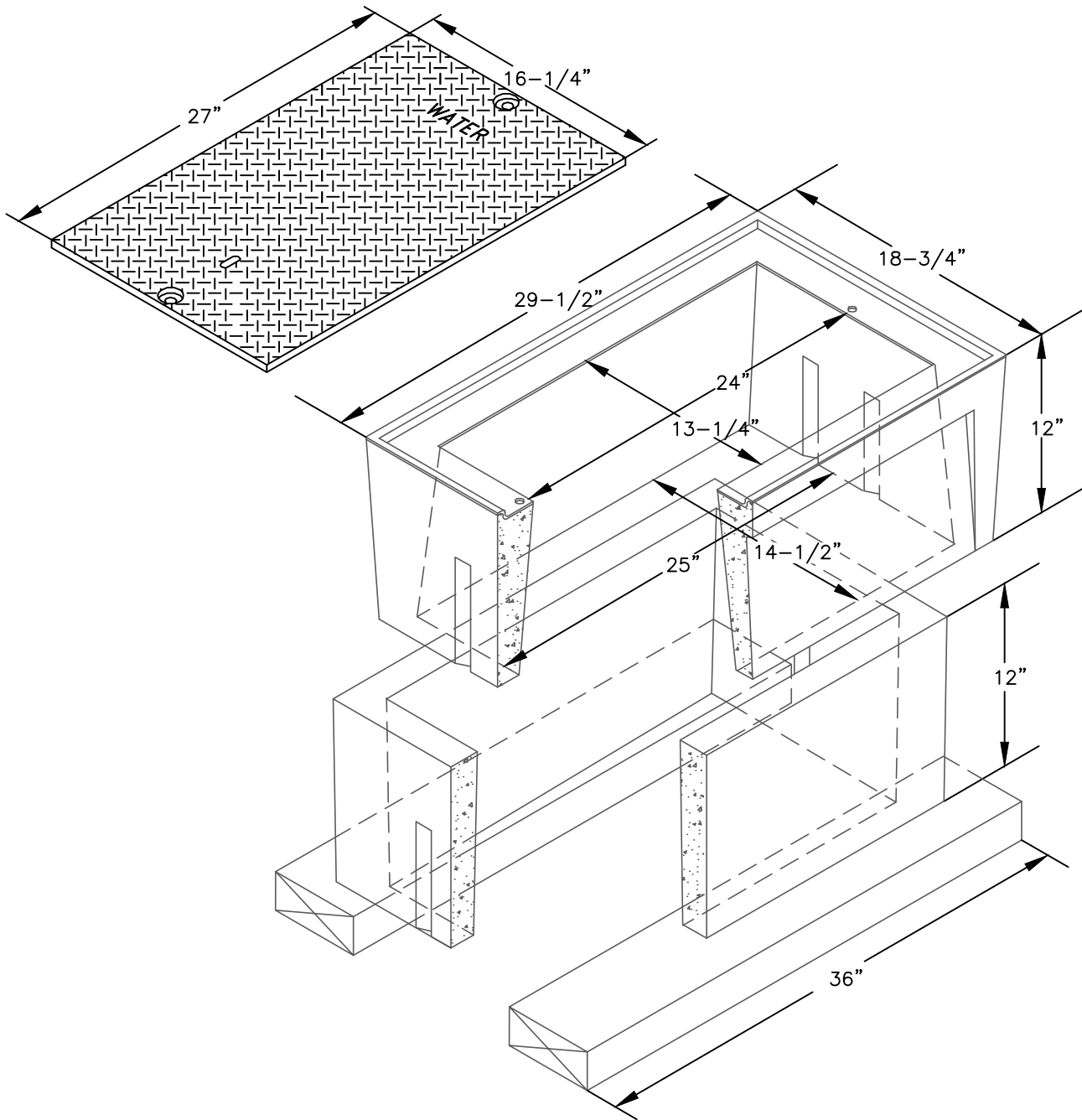

MATERIAL LIST

ITEM ID	QTY.	DESCRIPTION
ENCL-13x24	1.0	ENCLOSURE 13X24 TRAFFIC H/20 RATED
ENCL-13X24-LID	1.0	COVER 13X24 TRAFFIC H/20 RATED - MARKED "WATER"
ENCL-13X24-EXT	1.0	EXTENSION BOX 13X24 TRAFFIC H/20 RATED
RDWD-BRD-2X6X36	2.0	BOARD - REDWOOD 2" X 6" X 36"

SOURCE: TMWA DETAIL 10K-17



DRAWN: \_\_\_\_\_ NT  
 CHECKED: \_\_\_\_\_ CLR  
 REV: \_\_\_\_\_ MAY 2024  
 REV: \_\_\_\_\_

STANDARD DETAIL  
 NEW INSTALL - 13"x24"  
 ENCLOSURE - TRAFFIC RATED

WATER  
 2.11.10



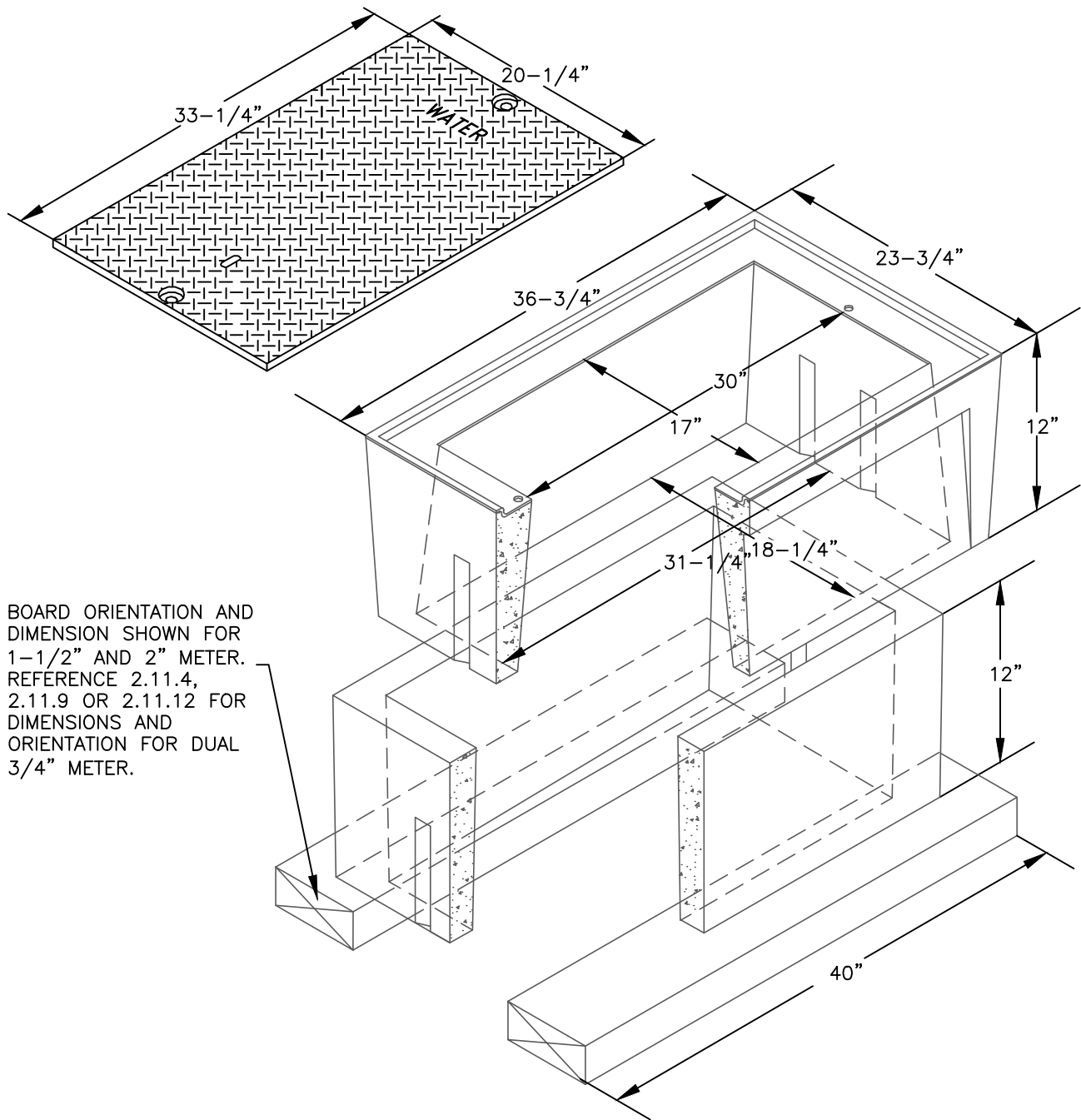

BOARD ORIENTATION AND DIMENSION SHOWN FOR 1-1/2" AND 2" METER. REFERENCE 2.11.4, 2.11.9 OR 2.11.12 FOR DIMENSIONS AND ORIENTATION FOR DUAL 3/4" METER.

MATERIAL LIST

ITEM ID	QTY.	DESCRIPTION
ENCL-17X30	1.0	ENCLOSURE 17X30 TRAFFIC H/20 RATED
ENCL-17X30-LID	1.0	COVER 17X30 TRAFFIC H/20 RATED - MARKED "WATER"
ENCL-17X30-EXT	1.0	EXTENSION BOX 17X30 TRAFFIC H/20 RATED
RDWD-BRD-2X6X40	2.0	BOARD - REDWOOD 2" X 6" X 40"

SOURCE: TMWA DETAIL 10K-18



DRAWN: \_\_\_\_\_ NT  
 CHECKED: \_\_\_\_\_ CLR  
 REV: \_\_\_\_\_ MAY 2024  
 REV: \_\_\_\_\_

STANDARD DETAIL  
 NEW INSTALL - 17"x30"  
 ENCLOSURE - TRAFFIC RATED

WATER  
 2.11.11

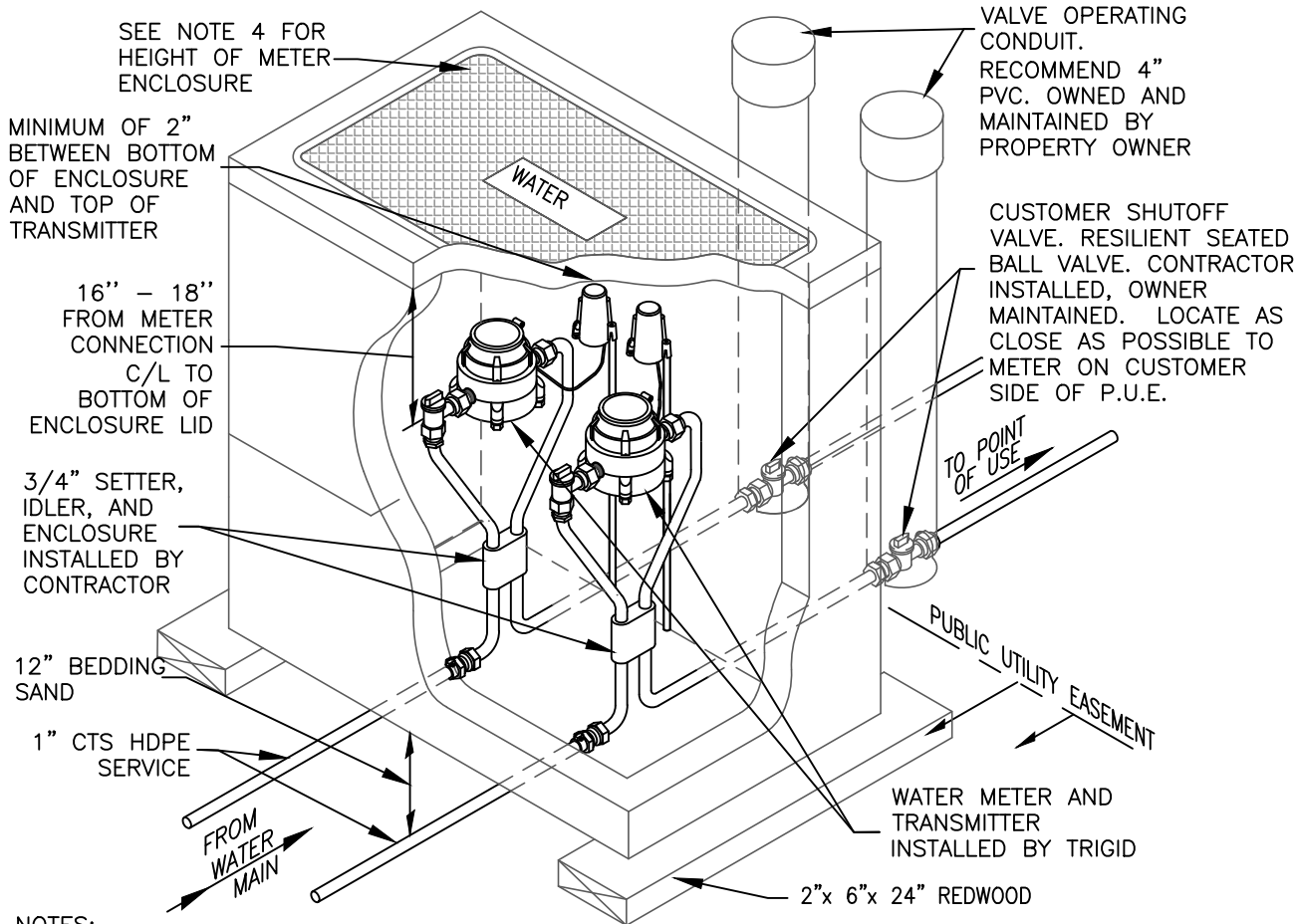

**NOTES:**

1. THERMAL EXPANSION PROTECTION IS REQUIRED IN ANY DOMESTIC WATER SUPPLY SYSTEM THAT IS DOWNSTREAM FROM A BACKFLOW PREVENTION DEVICE. REFERENCE: UNIFORM PLUMBING CODE.
2. METER AND TRANSMITTER SUPPLIED BY CONTRACTOR AND INSTALLED BY TRIGID.
3. FOR DRIVEWAY OR TRAFFIC AREAS USE 17X30 ENCLOSURE APPROVED FOR TRAFFIC RATED H/20 LOADING. SEE DETAIL 2.11.11.
4. TOP OF METER ENCLOSURE SHALL BE SET 0.2 FEET ABOVE HIGHEST FINISHED GRADE SURROUNDING ENCLOSURE WITHIN LANDSCAPED AREAS, AND SHALL BE SET FLUSH WITH SURROUNDING FINISH GRADE IN TRAFFIC AREAS.
5. ENCLOSURE TO BE BACKFILLED WITH WATER PIPE BEDDING SAND ONLY, SEE DETAILS 2.17-2.18.
6. BLANKET TO BE INSTALLED ABOVE METER AND BELOW TRANSMITTER.

**MATERIAL LIST**

ITEM ID	QTY.	DESCRIPTION
MS-0.75	2.0	SETTER WATER METER, NEW 3/4" MIP ENDS
WSC-1.00x0.75-CTSxFIP	2.0	COUPLING SERVICE 1" CTS COMPRESSION X 3/4" FIP
SSL-1.00	2.0	LINER RIGID STAINLESS STEEL FOR 1" CTS HDPE TUBING
GSKT-0.75	4.0	GASKET-3/4" FOR WATER METER
WM-DISC-0.75	2.0	3/4" WATER METER - SUPPLIED AND INSTALLED BY CONTRACTOR
ENCL-17x30-NT	1.0	ENCLOSURE NON-TRAFFIC 17 X 30 WATER METERS, SEE NOTE 3
ENCL-17x30-LID-NT	1.0	COVER NON-TRAFFIC 17 X 30, NON CONCRETE FIBRELYTE LID, SEE NOTE 3
ENCL-17x30-EXT-NT	1.0	EXTENSION BOX NON-TRAFFIC 17 X 30, SEE NOTE 3
INSL-BLKT-4x4	1.0	BLANKET INSULATION 4' X 4' FOR WATER METERS
RDWD-BRD-2x6x24	2.0	BOARD - REDWOOD 2" X 6" X 24"
IDLR-0.75	2.0	IDLER WATER METER 3/4" SETTER
ERT	2.0	REMOTE TRANSMITTER - SUPPLIED BY CONTRACTOR AND INSTALLED BY TRIGID

SOURCE: TMWA DETAIL 10K-11



DRAWN: \_\_\_\_\_ NT  
 CHECKED: \_\_\_\_\_ CLR  
 REV: \_\_\_\_\_ MAY 2024  
 REV: \_\_\_\_\_

STANDARD DETAIL

**NEW COMMERCIAL INSTALL - 1"  
 DUAL SERVICE FOR 3/4" SETTER,  
 METER, AND TRANSMITTER**

WATER

**2.11.12**



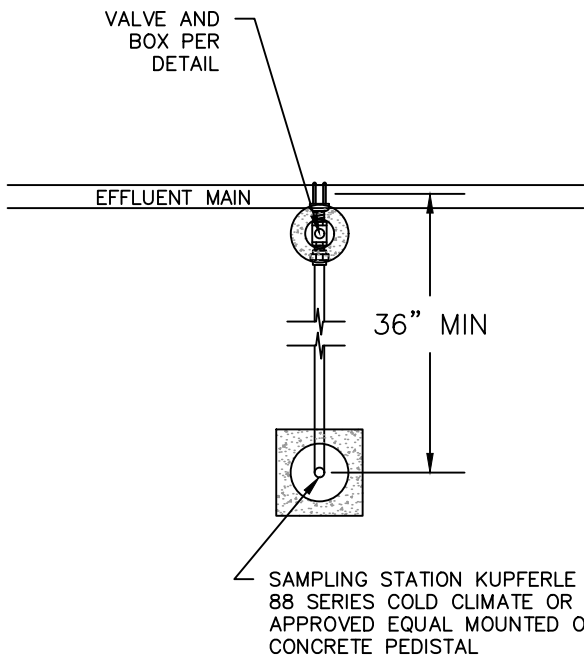

PLAN VIEW

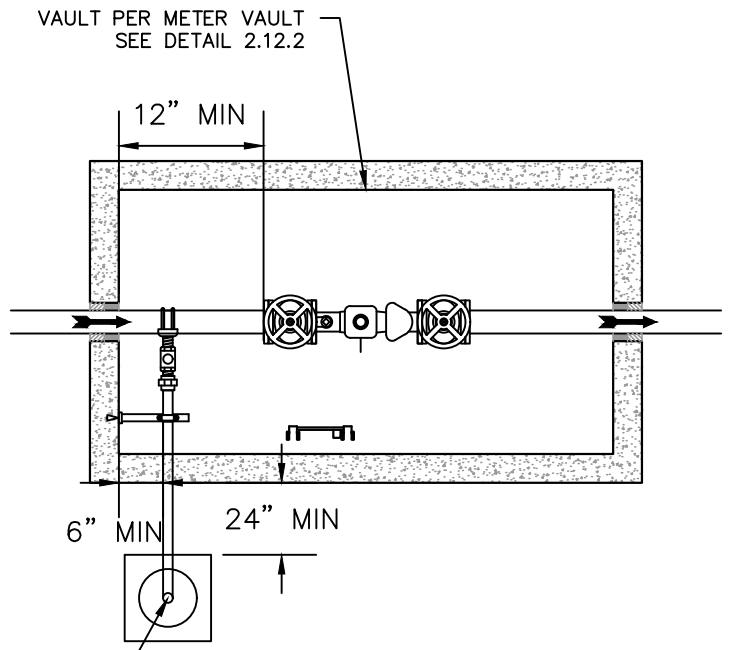

PLAN VIEW

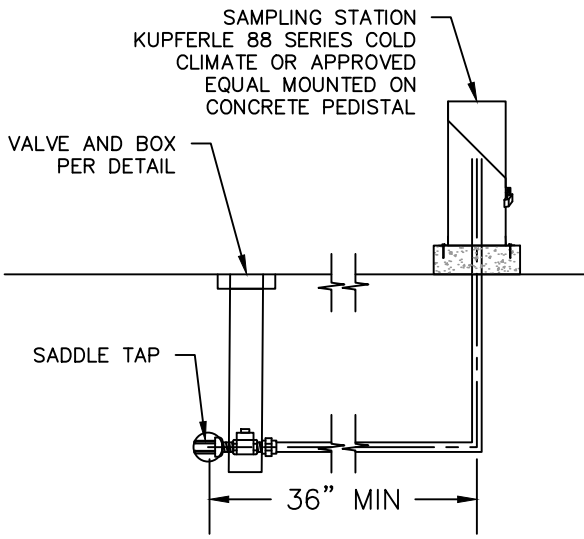

WITHOUT VAULT

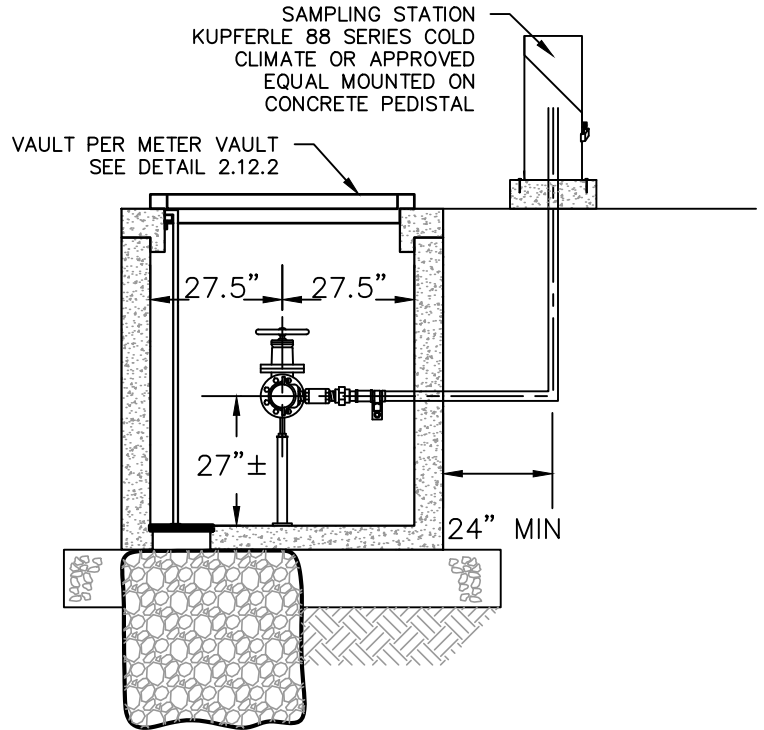

WITH VAULT

SOURCE: TMWA DETAIL XX-X



DRAWN: \_\_\_\_\_ NT  
 CHECKED: \_\_\_\_\_ CLR  
 REV: \_\_\_\_\_ MAY 2024  
 REV: \_\_\_\_\_

STANDARD DETAIL

WATER

SAMPLING STATION

2.12.1

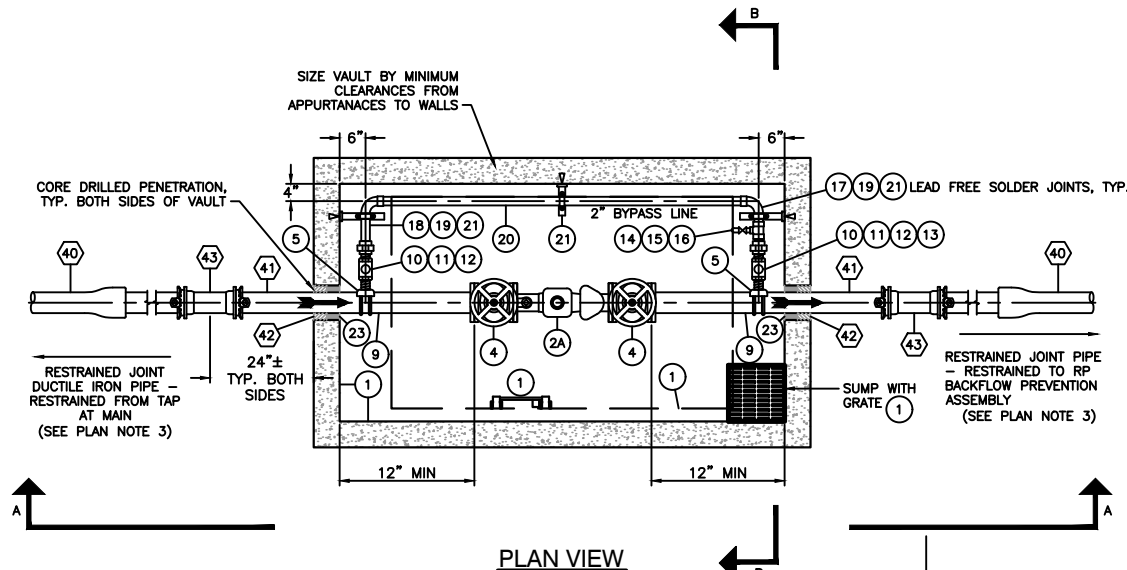

PLAN VIEW

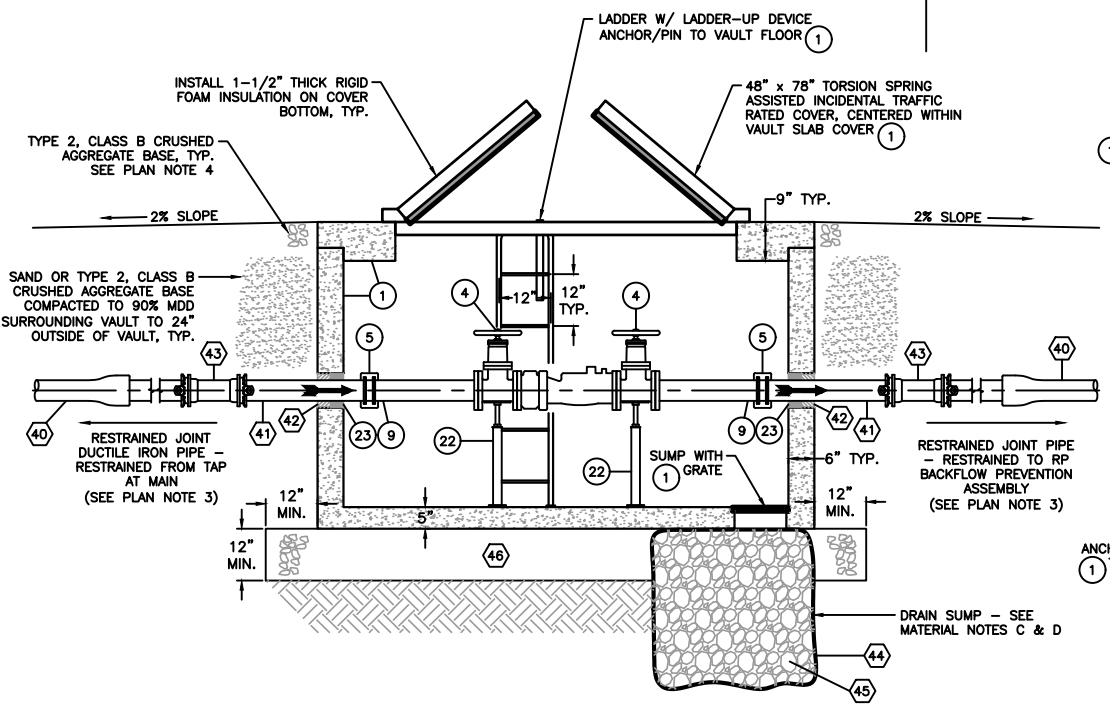

SECTION A - A

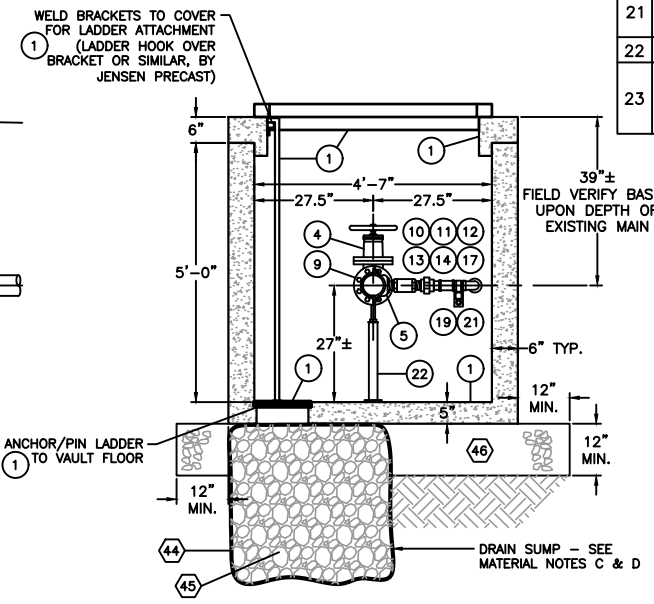

SECTION B - B

- PLAN NOTES:
1. ALL VAULT WALL PENETRATIONS SHALL BE CORE DRILLED IN THE FIELD.
  2. METAL COATING FINISH NOTE: APPLICABLE TO ALL METAL SUCH AS STEEL PIPING, BRACKETS, PIPE SUPPORTS, ETC. (EXCLUDING THREADED SURFACES), WHICH HAVE NOT BEEN COATED WITH FUSION BONDED EPOXY. USE TWO-COAT SELF-PRIMING EPOXY SYSTEM CARBOLINE 801. AN ACCEPTABLE ALTERNATIVE COATING SYSTEM IS SHERWIN WILLIAMS EPOXY MASTIC 858 SERIES.
  3. ALL RESTRAINED JOINT PIPING SHALL BE DUCTILE IRON PIPE. BELL AND SPIGOT PUSH-ON JOINTS SHALL BE RESTRAINED USING FIELD LOK 350 GASKETS AS MANUFACTURED BY U.S. PIPE OR TRI GID APPROVED EQUIVALENT. RESTRAINED JOINT FITTINGS SHALL BE MECHANICAL JOINT (MJ) DUCTILE IRON WITH MECHANICAL JOINT WEDGE ACTION RESTRAINT GLANDS. MECHANICAL JOINT WEDGE ACTION RESTRAINT GLANDS SHALL BE MEGALUG SERIES 1100 AS MANUFACTURED BY EBAA IRON, INC. OR TRI GID APPROVED EQUIVALENT.
  4. FINISH SURFACE TO CONSIST OF 6" TYPE 2, CLASS B CRUSHED AGGREGATE BASE COMPACTED TO 95% MDD EXTENDING MIN. 2 FEET BEYOND VAULT WALLS (UNLESS OTHERWISE SPECIFIED IN THE WATER IMPROVEMENT PLANS). GRADE SLOPE AWAY FROM VAULT AT 2%. FINAL SITE IMPROVEMENTS TO BE APPROVED BY TRI GID INSPECTOR.
  5. ALL DUCTILE IRON PIPE AND FITTINGS SHALL BE ENCASED IN POLYETHYLENE ENCASEMENT CONFORMING TO AWWA C105. ENCASEMENT SHALL EXTEND AT LEAST TWO FEET BEYOND JOINT AND SHALL BE TAPED SECURELY TO PIPE.
  6. METER TO BE SUPPLIED BY CUSTOMER.

- MATERIAL NOTES:
- A. REFERENCE WATER IMPROVEMENT PLANS FOR CONTINUATION OF MATERIAL REQUIREMENTS OUTSIDE OF VAULT.
  - B. ALL MATERIALS NOT PER MATERIAL LIST AND SPECIFICATIONS SHALL REQUIRE SUBMITTAL TO ENGINEER FOR APPROVAL PRIOR TO ORDERING.
  - C. DESIGN ENGINEER SHALL DETERMINE DEPTH TO GROUND WATER. FOR INSTALLATIONS IN AREAS OF HIGH GROUND WATER, DESIGN ENGINEER SHALL COORDINATE VAULT DESIGN MITIGATION WITH JENSEN PRECAST. **DO NOT INSTALL DRAIN SUMP.**
  - D. LINE ALL SIDES OF DRAIN SUMP WITH MIRAFI FILTERWEAVE 402 GEOTEXTILE FABRIC PER MANUFACTURER'S APPLICATION TECHNIQUES. BOTTOM OF DRAIN ROCK SHALL BE MINIMUM 2 FEET ABOVE HIGHEST GROUND WATER ELEVATION.

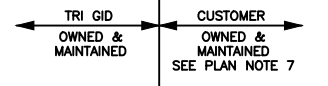

MATERIAL LIST

○ INSIDE VAULT

NO.	QTY.	DESCRIPTION
1	1	JENSEN PRECAST INCIDENTAL TRAFFIC LOAD VAULT WITH 12" x 12" SUMP. EXTERIOR VAULT WALLS, BASE, AND SLAB COVER SHALL BE FACTORY WATER SEALED WITH SONNEBORN HLM5000T BY JENSEN PRECAST.
	1	4878/557 GALVANIZED COVER WITH PADLOCK HASP, 48" x 78" TORSION SPRING ASSISTED WITH INCIDENTAL TRAFFIC RATING
	1	12"W x 66"±L REMOVABLE STEEL LADDER WITH LADDER-UP DEVICE. ANCHOR/PIN LADDER TO VAULT FLOOR. TO BE SUPPLIED BY JENSEN PRECAST. FIELD VERIFY LENGTH.
	1	13" X 13" "POLYLOK" GRATE PROVIDED AND INSTALLED BY JENSEN PRECAST
2A	1	METER, OMNI T2 WATER METER WITH FLANGES, (RET) RECORDALL ELECTRONIC TRANSMITTER (NOTE 6) WITH STRAINER
4	2	FLG x FLG RESILIENT WEDGE GATE VALVE W/ HAND WHEEL - MUELLER A-2361 W/ FACTORY FUSION EPOXY COATING, AWWA C-509 W/ NRS
5	2	DI PIPE X 2" NPT, DOUBLE STRAP SERVICE SADDLE, ROMAC 202NS NYLON COATED SADDLE W/ DOUBLE STAINLESS STEEL STRAPS
6	1	FLANGE COUPLING ADAPTER, ROMAC INDUSTRIES FUSION EPOXY STYLE "FCA501"
7	1	SPOOL DUCTILE IRON PIPE, FLG X PE (22" OR 28" IN LENGTH, SEE PLAN NOTE 6)
8	1	SPOOL DUCTILE IRON PIPE, FLG X FLG (10" IN LENGTH)
9	2	FLG X PE DI PIPE - FACTORY CEMENT-MORTAR LINED INTERIOR W/ ASPHALTIC COATING ON EXTERIOR, (38"± IN LENGTH)
10	2	BALL VALVE, BRASS, 2" NPT X NPT, FULL PORT, 600 PSI WOG W/ LOCKABLE S.S. HANDLE NORMALLY CLOSED POSITION (NIBCO T-FP-600N)
11	4	2" NIPPLE, NPT X NPT BRONZE (4"± IN LENGTH)
12	2	2" DIELECTRIC UNION, NPT X SOLDER JOINT (WATTS SERIES 3001A)
13	1	2"Ø NIPPLE TYPE K (HARD) COPPER, SOLDER JOINT X SOLDER JOINT (4"± LONG)
14	1	2" x 2" x 3/4" COPPER TEE, SOLDER JOINT X SOLDER JOINT X SOLDER JOINT
15	1	3/4" FITTING ADAPTER, SOLDER JOINT X FEMALE NPT
16	1	3/4" BRASS QUARTER-TURN HOSE BIB (NIBCO C-26)
17	1	2"Ø TYPE K (HARD) COPPER, SOLDER JOINT X SOLDER JOINT (LENGTH AS REQUIRED)
18	1	2"Ø TYPE K (HARD) COPPER, SOLDER JOINT X SOLDER JOINT (LENGTH AS REQUIRED)
19	2	2"Ø 90° COPPER LONG RADIUS ELBOW, SOLDER JOINT X SOLDER JOINT
20	1	2"Ø TYPE K (HARD) COPPER, SOLDER JOINT X SOLDER JOINT (7"-2"±)
21	3	1-5/8" ROLLED CHANNEL BRACKET W/ 2" CUSHION CLAMP (UNISTRUT NO. P2945 & 038N044). ATTACH TO WALL WITH (2) 1/2"Ø EXPANSION ANCHOR BOLTS
22	2	ADJUSTABLE PIPE SUPPORT
23	2	CALPICO CSL-40-SS ASSEMBLY OF EPDM RUBBER (TOTAL OF 5 LINKS) W/ S.S. BOLTS AND COMPRESSION PLATES FOR 4" DUCTILE IRON PIPE THROUGH AN 8"Ø VAULT BORE HOLE

◇ OUTSIDE VAULT

NO.	QTY.	DESCRIPTION
40	REF.	RESTRAINED JOINT DUCTILE IRON PIPE, BELL WITH FIELD LOK 350 GASKET, ANSI/AWWA C111/A21.11 (U.S. PIPE) - (SEE MATERIAL NOTE A AND PLAN NOTE 3).
41	2	DUCTILE IRON PIPE - SEE NUMBER 9 INSIDE VAULT
42	2	NON-SHRINKING GROUT - FILL ANNULAR SPACE FLUSH WITH VAULT WALL
43	2	MJ x MJ DUCTILE IRON SOLID SLEEVE - LONG (AWWA C110 OR C153) WITH MECHANICAL JOINT WEDGE ACTION RESTRAINT GLANDS - 2 (SEE PLAN NOTE 3)
44	60± SF	MIRAFI FILTERWEAVE 402 GEOTEXTILE FABRIC
45	27 CF	DRAIN ROCK, 3"Ø MINUS FOR SUMP (3' x 3' x 3')
46	90± CF	CRUSHED DRAIN ROCK, 3/4" NOMINAL FOR VAULT BASE. EXTEND BASE ROCK TO 12" BEYOND VAULT FOOTPRINT

NT  
CLR  
MAY 2024  
DRAWN: \_\_\_\_\_  
CHECKED: \_\_\_\_\_  
REV: \_\_\_\_\_  
REV: \_\_\_\_\_



STANDARD DETAIL  
METER VAULT AND ASSEMBLY 4" TO 10"

WATER

2.12.2

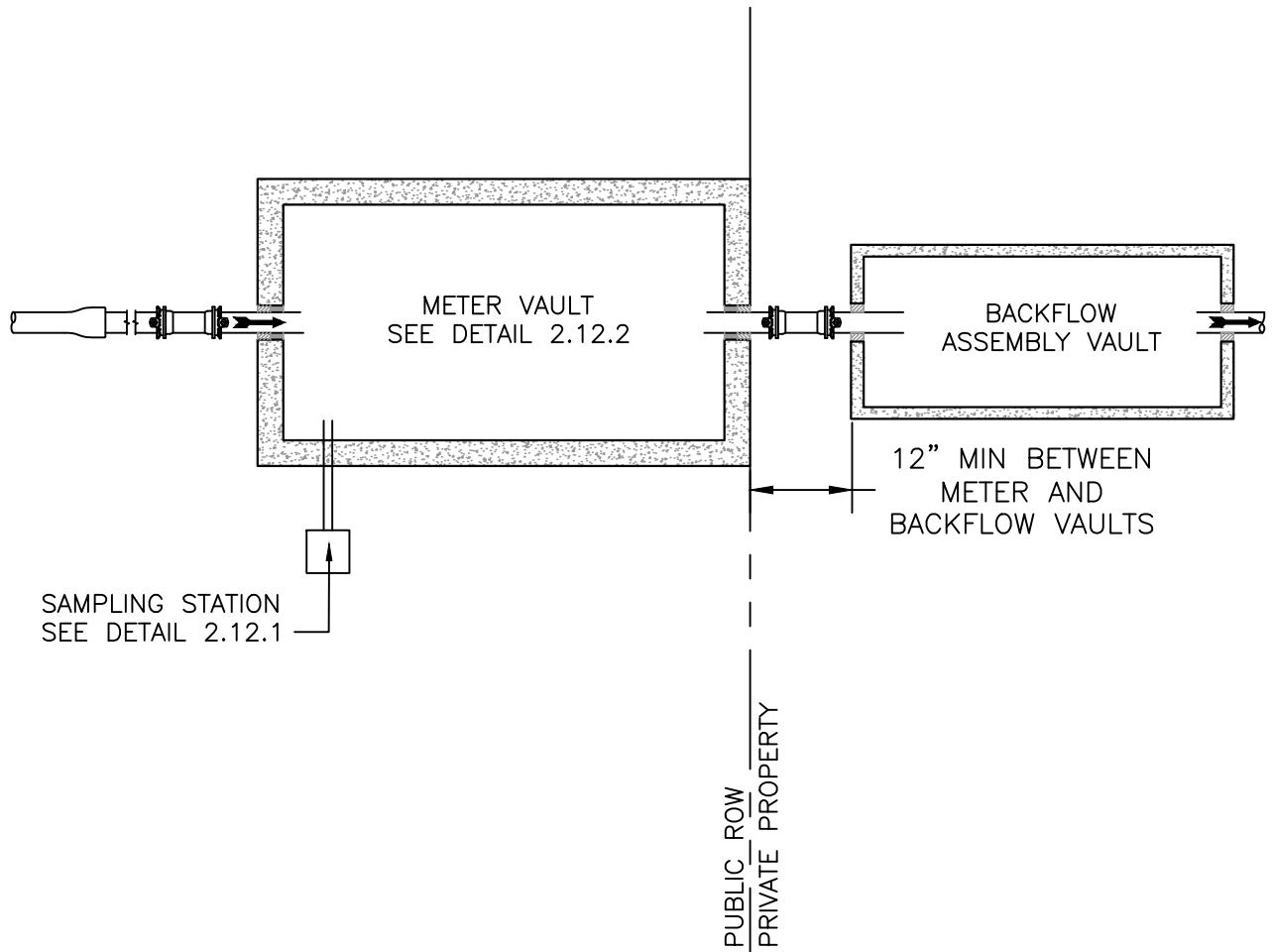

SOURCE: TMWA DETAIL XX-X

 <p>440 USA PKWY, SUITE 105 McCARRAN, NEVADA 89437</p>	DRAWN: _____ NT CHECKED: _____ CLR REV: _____ MAY 2024 REV: _____	STANDARD DETAIL	WATER
		<h2 style="text-align: center;">BACKFLOW PREVENTION ASSEMBLY 4"-10"</h2>	2.12.3

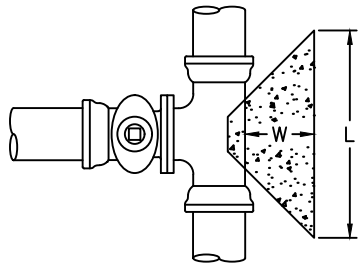

TEE / TAPPING SLEEVE PLAN VIEW

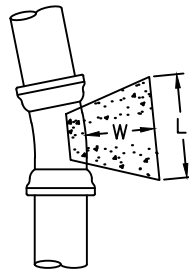

11.25° ELBOW PLAN VIEW

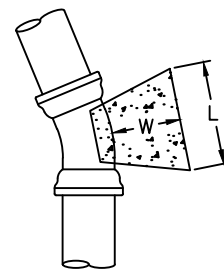

22.5° ELBOW PLAN VIEW

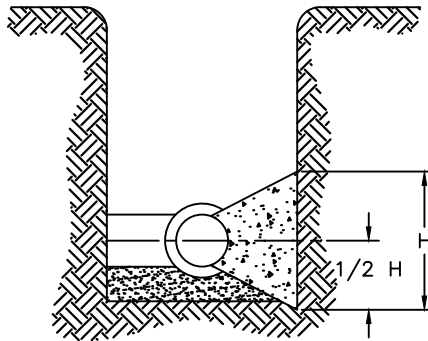

TYPICAL SECTION VIEW

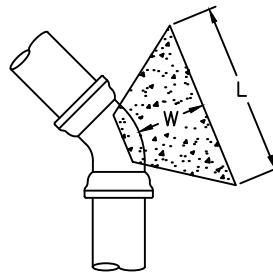

45° ELBOW PLAN VIEW

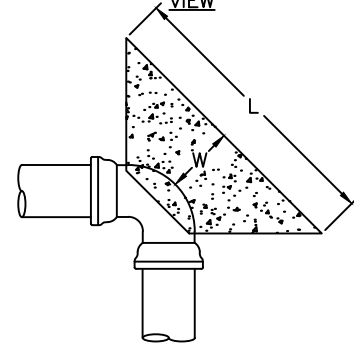

90° ELBOW PLAN VIEW

THRUST BLOCK DIMENSIONS

TEE, TAP, OR DEAD END					11.25° ELBOW			22.5° ELBOW			45° ELBOW			90° ELBOW		
BRANCH SIZE (INCHES)	L (FEET)	H (FEET)	W MIN. (FEET)	ELBOW SIZE (INCHES)	L (FEET)	H (FEET)	W MIN. (FEET)	L (FEET)	H (FEET)	W MIN. (FEET)	L (FEET)	H (FEET)	W MIN. (FEET)	L (FEET)	H (FEET)	W MIN. (FEET)
4	1.5	1	1	4	1	1	1	1	1	1	1.5	1	1	2	1	1
6	2	2	1	6	1	1	1	1.5	1	1	2	1.5	1	2.5	2	1
8	3	2	1	8	1.5	1	1	1.5	1.5	1	2.5	2	1	4	2	1
10	3.5	2.5	1	10	2	1	1	2	2	1	3	2.5	1	5	2.5	1
12	4.5	3	1	12	2	1.5	1	2.5	2	1	4	2.5	1	6	3	1

THRUST BLOCK DESIGN CRITERIA:

THRUST BLOCK SIZES HAVE BEEN CALCULATED USING THE METHOD AND EQUATIONS PUBLISHED IN *THRUST RESTRAINT DESIGN FOR DUCTILE IRON PIPE, SIXTH EDITION 2006* BY THE DUCTILE IRON PIPE RESEARCH ASSOCIATION (DIPRA) UTILIZING THE FOLLOWING DESIGN PARAMETERS:  
 DESIGN PRESSURE = 150 PSI (SEE NOTE #4 BELOW), SOIL BEARING CAPACITY = 2,000 PSF (SEE NOTE #4 BELOW), SAFETY FACTOR = 1.5, AND NOMINAL PIPE DIAMETER

THRUST BLOCK NOTES:

- CONCRETE FOR THRUST BLOCKS SHALL HAVE A MINIMUM 28-DAY COMPRESSIVE STRENGTH OF 3,000 PSI. REFERENCE SECTION 1.1.13 OF THE TRIGID ENGINEERING & CONSTRUCTION STANDARDS FOR ADDITIONAL REQUIREMENTS. BAG CONCRETE MIX IS NOT ACCEPTABLE.
- ALL FITTINGS SHALL BE WRAPPED WITH POLYETHYLENE WRAP PER AWWA C105. MASTIC (BRUSH-ON) SHALL BE APPLIED TO ALL BOLTS, ETC.
- THRUST BLOCKS SHALL BE POURED AGAINST UNDISTURBED SOIL. IN CASES WHERE THIS IS NOT PRACTICAL, BACKFILL AREA BEHIND WHERE THRUST BLOCK WILL BE POURED WITH TYPE 2, CLASS B AGGREGATE BASE (PER SECTION 200.01.03 OF THE STANDARD SPECIFICATIONS FOR PUBLIC WORKS CONSTRUCTION - ORANGE BOOK) COMPACTED TO 95% MAXIMUM DRY DENSITY AT OPTIMUM MOISTURE CONTENT AS DETERMINED BY PROCEDURES SET FORTH IN ASTM D 1557, CUT-BACK COMPACTED AGGREGATE BASE TO EXPOSE A FIRM SURFACE, THEN POUR THRUST BLOCK.
- FOR SOIL BEARING CAPACITY LESS THAN 2,000 PSF AND/OR DESIGN PRESSURE IN EXCESS OF 150 PSI, INCREASE THRUST BLOCK BEARING AREAS ACCORDINGLY. REVISED THRUST BLOCK SCHEDULE FOR SPECIFIC CONDITIONS SHALL BE SUBMITTED BY THE DESIGN ENGINEER.

SOURCE: TMWA DETAIL 10L-2



DRAWN: \_\_\_\_\_ NT  
 CHECKED: \_\_\_\_\_ CLR  
 REV: \_\_\_\_\_ MAY 2024  
 REV: \_\_\_\_\_

STANDARD DETAIL

THRUST AND ANCHOR BLOCKS

WATER

2.14.1

PLACER WATERWORKS, INC CATALOG #AE3618MT FOR LID AND RISER TUBE

6"Ø SDR 35 PIPE WITH G5 VALVE BOX WITH COVER MARKED "WATER". LOCATED OUT OF TRAFFIC AREA.

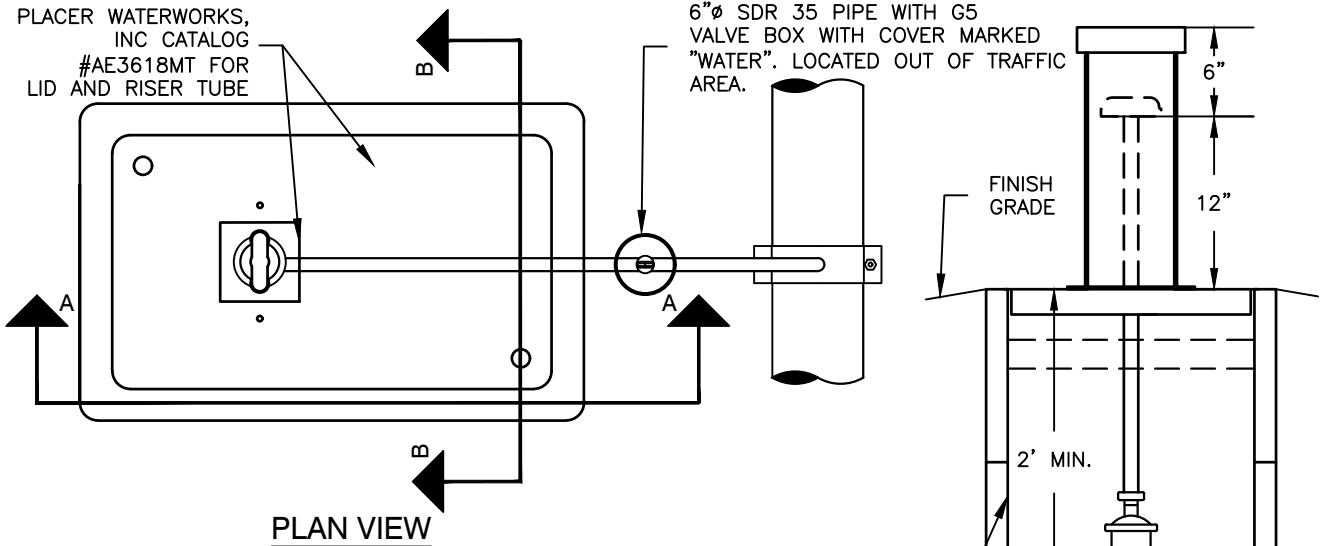

PLAN VIEW

SECTION B-B

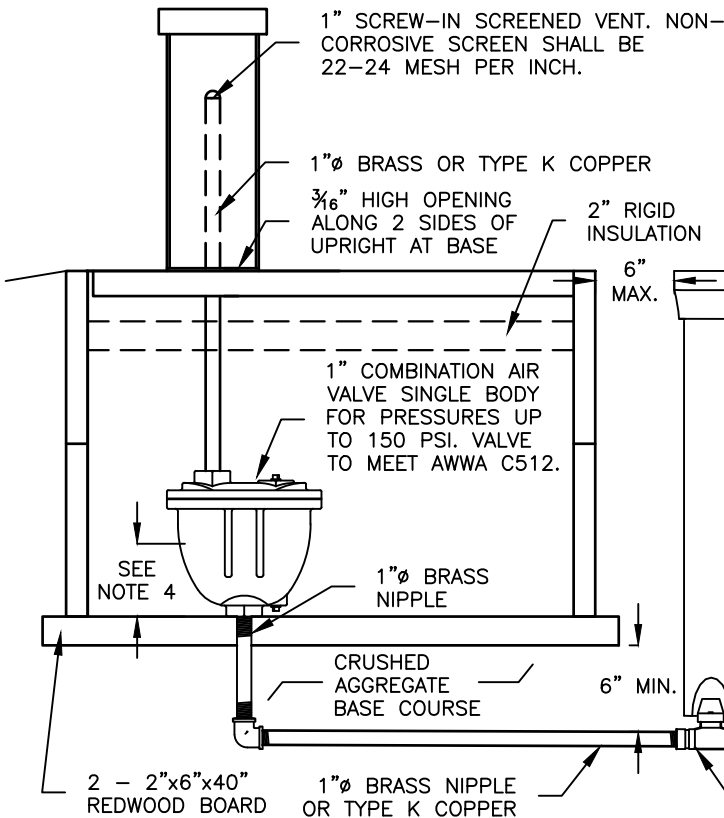

SECTION A-A

NOTES

1. REFER TO DETAIL 2.8.1 FOR SERVICE TAP INSTALLATION.
2. REFER TO DETAIL 2.17 FOR TRENCH BEDDING AROUND HDPE PORTION OF THIS DETAIL. BEDDING SAND TO BE USED UNLESS OTHERWISE CALLED FOR.
3. TOP OF ENCLOSURE AND VALVE CAP SHALL BE SET 0.2 FEET ABOVE HIGHEST FINISHED GRADE SURROUNDING ENCLOSURE WITH LANDSCAPE AREAS.
4. PLACE TYPE 2 CLASS B CRUSHED AGGREGATE BASE WITHIN BOX TO EXTEND HALF WAY UP BODY OF THE ARV AND EXTEND UNDER BOX TO A DEPTH OF 6" BELOW THE BRASS NIPPLE/COPPER TUBE. BASE TO EXTEND FROM THE ARV TO THE CURB VALVE AND BEYOND THE EXTENTS OF THE ENCLOSURE FOR 6-INCHES.

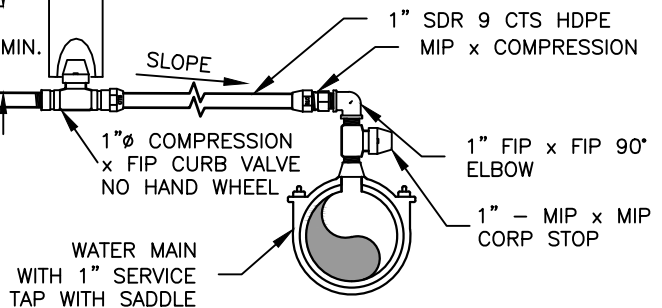

SOURCE: TMWA DETAIL 10L-4



DRAWN: \_\_\_\_\_ NT  
 CHECKED: \_\_\_\_\_ CLR  
 REV: \_\_\_\_\_ MAY 2024  
 REV: \_\_\_\_\_

STANDARD DETAIL

AIR RELEASE VALVE ASSEMBLY

WATER

2.15.1

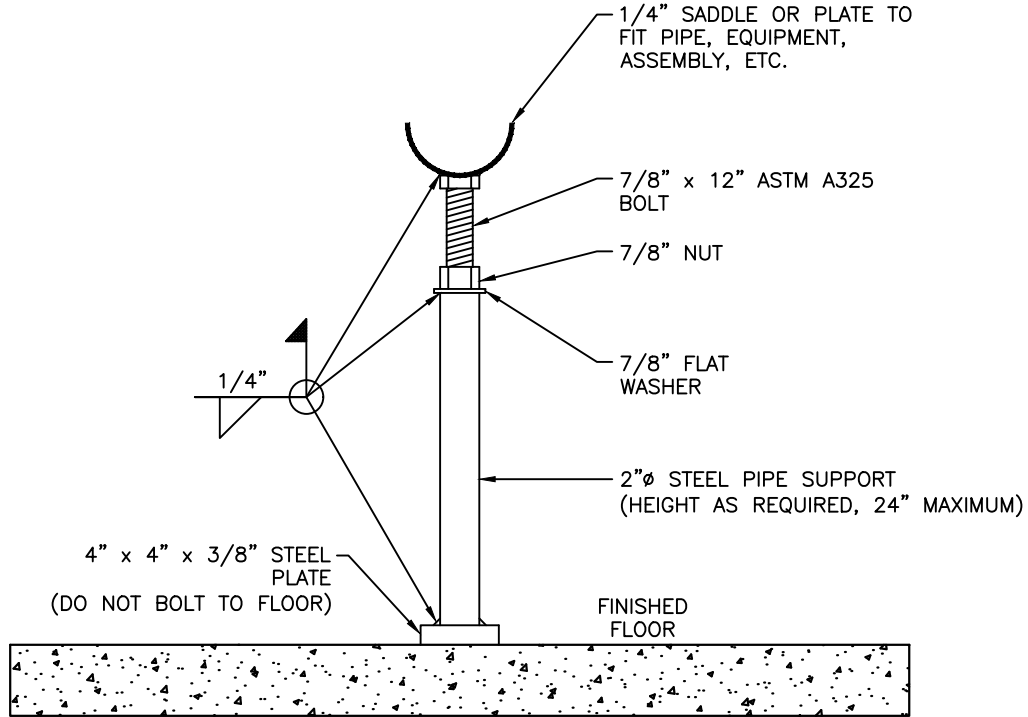

METAL COATING FINISH NOTE:

1. ALL NON-THREADED COMPONENTS, WHICH HAVE NOT BEEN COATED WITH FUSION BONDED EPOXY, SHALL BE COATED USING TWO-COAT SELF-PRIMING EPOXY SYSTEM CARBOLINE 801. AN ACCEPTABLE ALTERNATIVE COATING SYSTEM IS SHERWIN WILLIAMS EPOXY MASTIC B58 SERIES.
2. ALL METAL SURFACES TO BE COATED SHALL RECEIVE SURFACE PREPARATION EQUIVALENT TO POWER TOOL CLEANING (SSPC-SP3) BY POWER WIRE BRUSHING, POWER IMPACT TOOLS, OR POWER SANDERS, OR EQUIVALENT TO BRUSH-OFF BLAST CLEANING (SSPC-SP7) TO REMOVE RUST, MILL SCALE, AND OTHER DETRIMENTAL FOREIGN MATERIALS PRESENT UNTIL AT LEAST TWO-THIRDS OF EACH ELEMENT OF SURFACE AREA IS FREE OF ALL VISIBLE RESIDUE. APPLICATION OF THE EPOXY COATING SYSTEM SHALL FOLLOW IMMEDIATELY AFTER SURFACE PREPARATION. ANY CLEANED AREAS NOT COATED BEFORE CORROSION FORMS SHALL BE RE-CLEANED PRIOR TO THE APPLICATION OF THE EPOXY COATING.

SOURCE: TMWA DETAIL 10L-5



DRAWN: \_\_\_\_\_ NT  
 CHECKED: \_\_\_\_\_ CLR  
 REV: \_\_\_\_\_ MAY 2024  
 REV: \_\_\_\_\_

STANDARD DETAIL

**ADJUSTABLE PIPE  
SUPPORT**

WATER

2.16.1



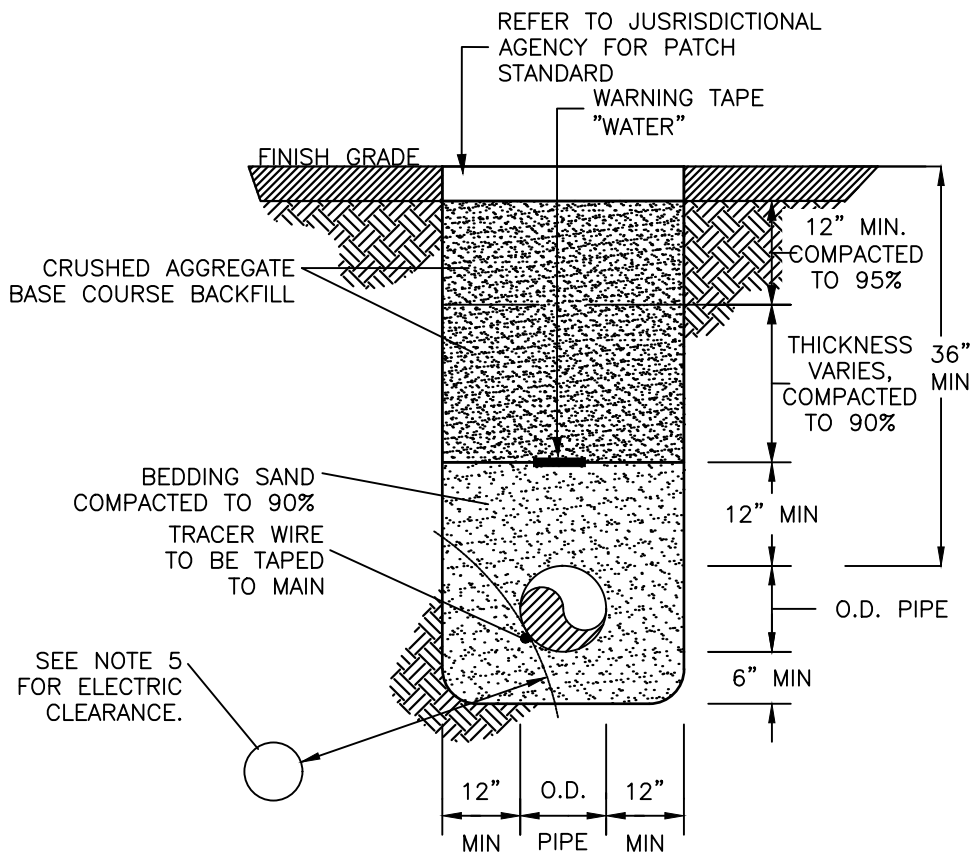

NOTES:

1. ALL TRENCHES MUST CONFORM TO APPLICABLE TRIGID, STATE, COUNTY, AND OSHA SPECIFICATIONS AND REQUIREMENTS. IN THE CASE OF CONFLICT, THE MORE RIGID SPECIFICATION OR STANDARD SHALL APPLY.
2. BEDDING SAND SHALL CONFORM WITH ORANGE BOOK CLASS A REQUIREMENTS, COMPACTED TO 90% MAXIMUM DENSITY, AND SHALL BE A MINIMUM OF 12" ABOVE AND 6" BELOW THE MAIN.
3. CRUSHED AGGREGATE BASE COURSE BACKFILL SHALL CONFORM TO ORANGE BOOK CLASS 2 TYPE B REQUIREMENTS AND BE PLACED IN 12" MAXIMUM LOOSE LIFTS. THE TOP 12" SHALL BE COMPACTED TO 95% MAXIMUM DENSITY. THE AREA ABOVE THE BEDDING SAND & BELOW 12" FROM FINISH GRADE SHALL BE COMPACTED TO 90% MAXIMUM DENSITY.
4. NON-METALLIC BLUE WARNING TAPE SHALL BE PLACED IN ALL TRENCHES AT LEAST 12" ABOVE THE WATER MAIN.
5. ELECTRIC UTILITIES MUST BE LOCATED BELOW WATER & MAINTAIN 2' MINIMUM RADIAL CLEARANCE FROM TRIGID WATER FACILITIES. IF 2' RADIAL CLEARANCE CAN NOT BE MET ELECTRIC CONDUIT MUST BE CONCRETE ENCASED AT LEAST 18" EACH SIDE OF WATER CROSSING. FIBER OPTIC AND/OR COMMUNICATION CONDUITS SHALL NOT BE PLACE IN THE SAME TRENCH AS WATER.
6. ALL CHANGES MUST BE APPROVED BY THE TRIGID INSPECTOR AND/OR THE TRIGID ENGINEER.
7. SEPARATION FOR PIPES IN A JOINT TRENCH SHALL BE A MINIMUM OF 12".
8. TRACER WIRE SHALL BE #14 COPPER CLAD STAINLESS STEEL CORE WITH 30 MILS BLUE HDPE INSULATION. ALL WIRE SPLICES SHALL BE MADE USING A SPLIT BOLT CONNECTOR WRAPPED WITH AQUASEAL AND ELECTRIC TAPE. THE CONTRACTOR SHALL INSTALL A 3 POUND ANODE AT EVERY TEST STATION. TEST STATIONS SHALL BE LOCATED ALONG THE MAIN NO MORE THAN 500 FEET APART. REFER TO SUBSECTION 2.21.2.

SOURCE: TMWA DETAIL 10L-6



DRAWN: \_\_\_\_\_ NT  
 CHECKED: \_\_\_\_\_ CLR  
 REV: \_\_\_\_\_ MAY 2024  
 REV: \_\_\_\_\_

STANDARD DETAIL

**TRENCH DETAIL -  
WATER ONLY**

WATER

**2.17.1**

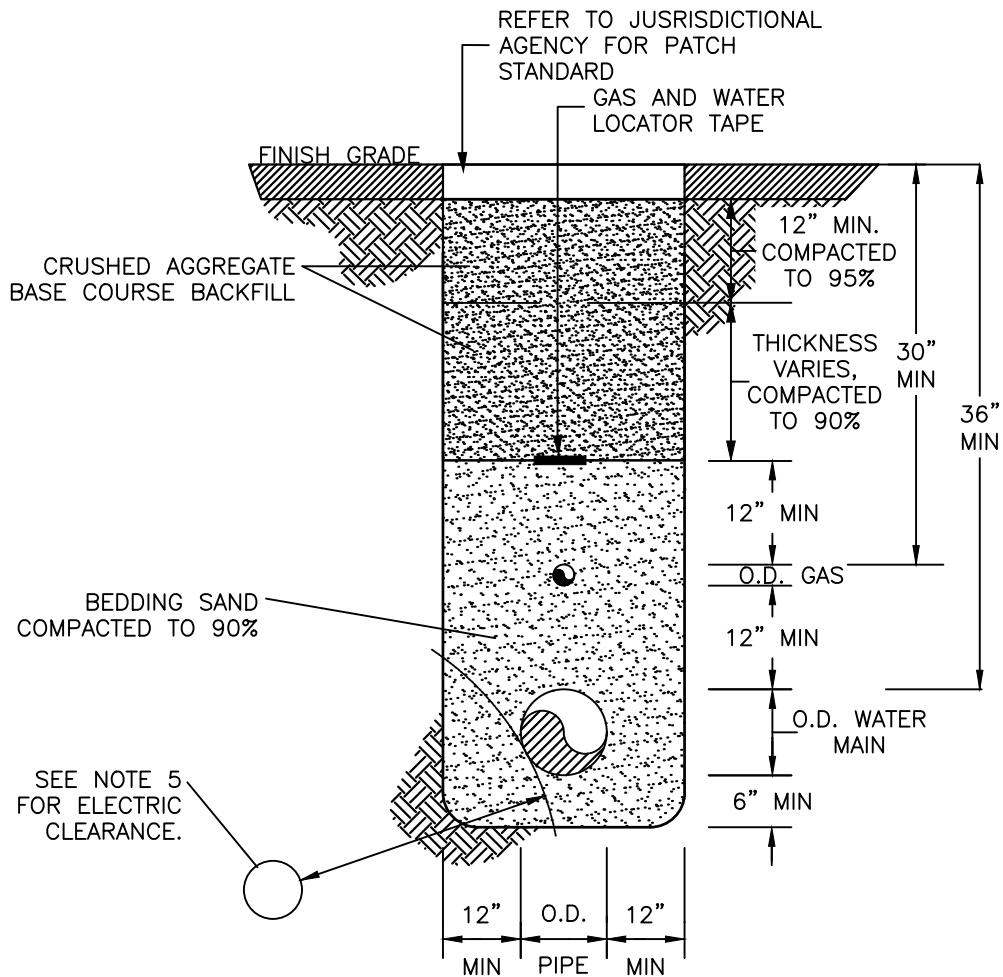

NOTES:

1. ALL TRENCHES MUST CONFORM TO APPLICABLE TRIGID, STATE, COUNTY, AND OSHA SPECIFICATIONS AND REQUIREMENTS. IN THE CASE OF CONFLICT, THE MORE RIGID SPECIFICATION OR STANDARD SHALL APPLY.
2. BEDDING SAND SHALL CONFORM TO ORANGE BOOK CLASS A REQUIREMENTS, BE COMPACTED TO 90% MAXIMUM DENSITY, AND SHALL BE A MINIMUM OF 12" ABOVE AND 6" BELOW THE MAIN.
3. CRUSHED AGGREGATE BASE COURSE BACKFILL SHALL CONFORM TO ORANGE BOOK CLASS 2 TYPE B REQUIREMENTS AND BE PLACED IN 12" MAXIMUM LOOSE LIFTS. THE TOP 12" SHALL BE COMPACTED TO 95% MAXIMUM DENSITY. THE AREA ABOVE THE BEDDING SAND & BELOW 12" FROM FINISH GRADE SHALL BE COMPACTED TO 90% MAXIMUM DENSITY.
4. METALLIC WATER AND GAS LOCATOR TAPE SHALL BE PLACED IN ALL TRENCHES AT LEAST 12" ABOVE THE GAS.
5. ELECTRIC UTILITIES MUST BE LOCATED BELOW WATER & MAINTAIN 2' MINIMUM RADIAL CLEARANCE FROM TRIGID WATER FACILITIES. IF 2' RADIAL CLEARANCE CAN NOT BE MET ELECTRIC CONDUIT MUST BE CONCRETE ENCASED AT LEAST 18" EACH SIDE OF WATER CROSSING. FIBER OPTIC AND/OR COMMUNICATION CONDUITS SHALL NOT BE PLACED IN THE SAME TRENCH AS WATER.
6. ALL CHANGES MUST BE APPROVED BY THE TRIGID INSPECTOR AND/OR THE TRIGID ENGINEER.
7. SEPARATION FOR PIPES IN A JOINT TRENCH SHALL BE A MINIMUM OF 12".

SOURCE: TMWA DETAIL 10L-7



DRAWN: \_\_\_\_\_ NT  
 CHECKED: \_\_\_\_\_ CLR  
 REV: \_\_\_\_\_ MAY 2024  
 REV: \_\_\_\_\_

STANDARD DETAIL

TRENCH DETAIL - GAS  
 AND WATER

WATER

2.18.1



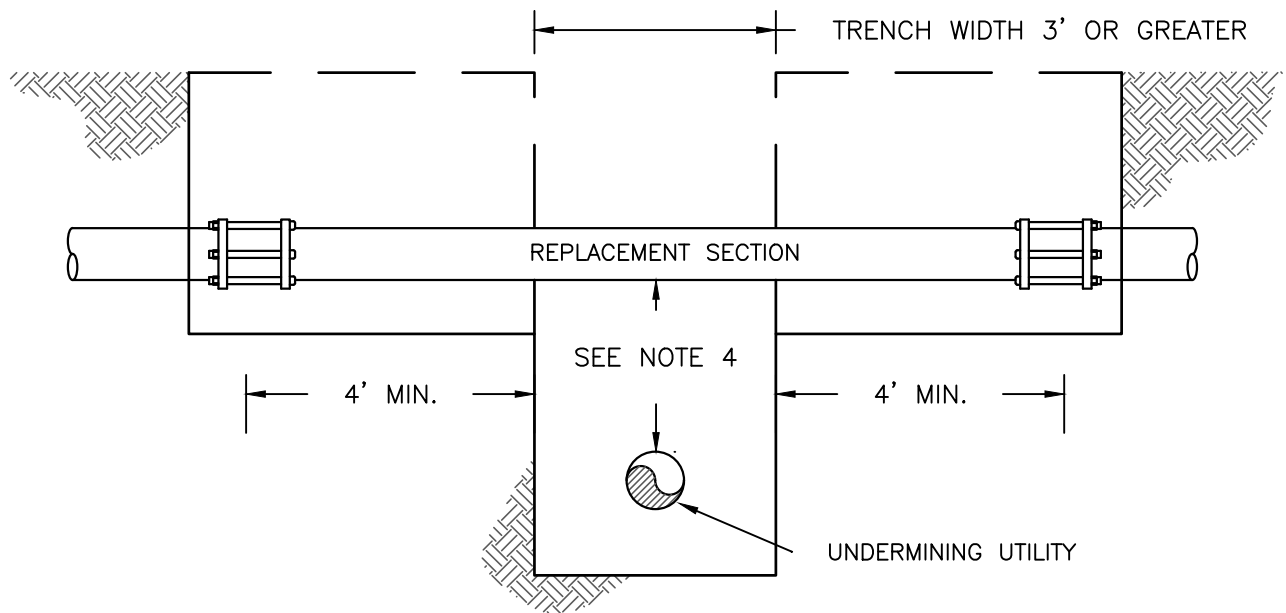

1. COUPLINGS SHALL BE ROMAC STYLE 501, FUSION EPOXY COATING, CENTER RING LENGTH MINIMUM 7".
2. BACKFILL AND COMPACTION REQUIREMENTS SHALL COMPLY WITH SECTION 5, TRENCH BEDDING, BACKFILL & EXCAVATION.
3. REPLACEMENT SECTION OF PIPE SHALL BE DUCTILE IRON.
4. REFER TO TRIGID STANDARD DETAILS FOR MINIMUM CLEARANCE REQUIREMENTS.

SOURCE: TMWA DETAIL 10L-8

 <p>440 USA PKWY, SUITE 105 McCARRAN, NEVADA 89437</p>	DRAWN: _____ NT CHECKED: _____ CLR REV: _____ MAY 2024 REV: _____	STANDARD DETAIL	WATER
		<b>CROSSING UNDER EXISTING TRANSITE OR SMALL DIAMETER CAST IRON MAINS</b>	<b>2.21.1</b>

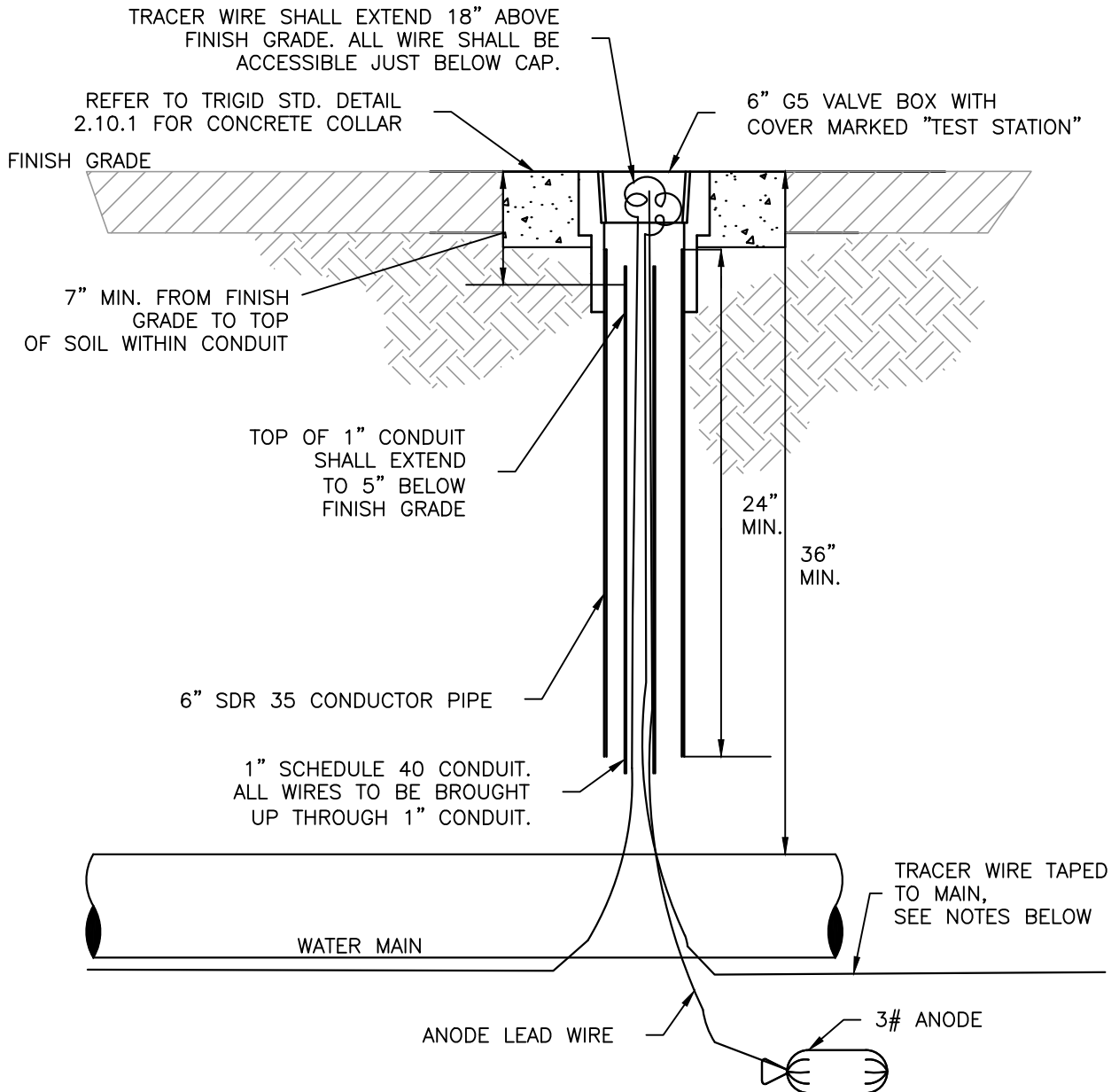

NOTES:

1. TRACER WIRE SHALL BE #14 COPPER CLAD STAINLESS STEEL CORE WITH 30 MILS BLUE HDPE INSULATION.
2. ALL WIRE SPLICES SHALL BE MADE USING A SPLIT BOLT CONNECTOR WRAPPED WITH AQUASEAL AND ELECTRIC TAPE.
3. CONTRACTOR SHALL INSTALL A 3 POUND ANODE AT EVERY TEST STATION.
4. TEST STATIONS SHALL BE LOCATED ALONG THE MAIN NO MORE THAN 500 FEET APART UNLESS OTHERWISE SPECIFIED ON THE PLANS.
5. PRIOR TO ACCEPTANCE OF WATER MAIN, THE CONTRACTOR SHALL PERFORM A CONTINUITY TEST ON THE INSTALLED TRACER WIRE SYSTEM.
6. WHERE DIRECTED, TRACER WIRE SHALL BE PLACED WITH ALL SERVICE LINES AND SHALL BE EXTENDED INTO THE METER BOX. TRACER WIRE SHALL BE ACCESSIBLE FROM METER BOX AND SHALL EXTEND 12 INCHES ABOVE GROUND. CONNECT TO MAIN TRACER WIRE AS SPECIFIED IN NOTE 2.

SOURCE: TMWA DETAIL 10L-9

 <p>440 USA PKWY, SUITE 105 McCARRAN, NEVADA 89437</p>	DRAWN: _____ NT CHECKED: _____ CLR REV: _____ MAY 2024 REV: _____	STANDARD DETAIL	WATER
		TEST STATION	2.21.2

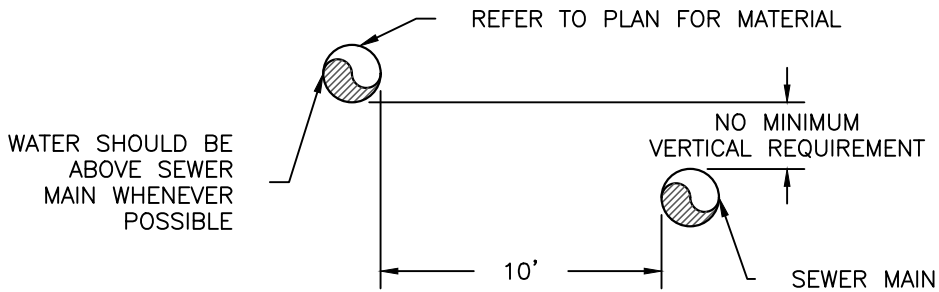

OPTION 1

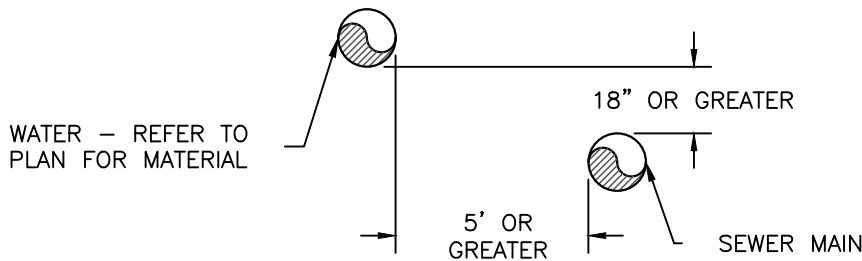

OPTION 2

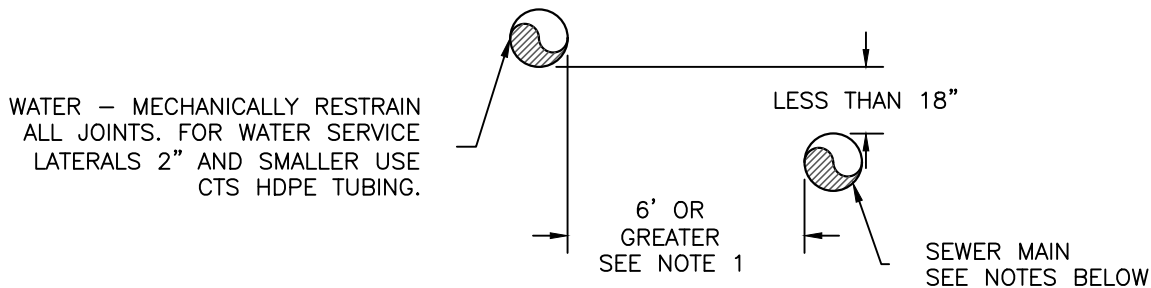

OPTION 3

NOTES:

1. IF SEPARATION IS 10 FEET OR MORE USE OPTION 1.
2. NON-PRESSURIZED SEWER MAINS SHALL BE SDR 35 PVC. IF SEWER MAINS ARE NON SDR 35 PVC, SEWER MAINS SHALL BE ENCASED IN 4" OF EXCAVATABLE SLURRY, USE EXTERNAL JOINT SEALANT OR OTHER MITIGATION TO ENSURE JOINTS ARE WATERTIGHT. WHERE THE SEWER MAINS ARE PRESSURIZED, THE SEWER MAINS SHALL HAVE MECHANICALLY RESTRAINED JOINTS OR SHALL USE WELDED OR FUSED PIPE.
3. FOR STORM SEWER MAINS WITH A DIAMETER OF 24" OR LARGER, THE SEWER MAINS SHALL BE INSTALLED WITH WATER TIGHT JOINTS THAT USE JOINT SEALANTS OR JOINT GASKETS.

SOURCE: TMWA DETAIL 10L-10



DRAWN: \_\_\_\_\_ NT  
 CHECKED: \_\_\_\_\_ CLR  
 REV: \_\_\_\_\_ MAY 2024  
 REV: \_\_\_\_\_

STANDARD DETAIL

WATER MAIN OR LATERAL  
 PARALLEL TO SEWER MAIN

WATER

2.21.3

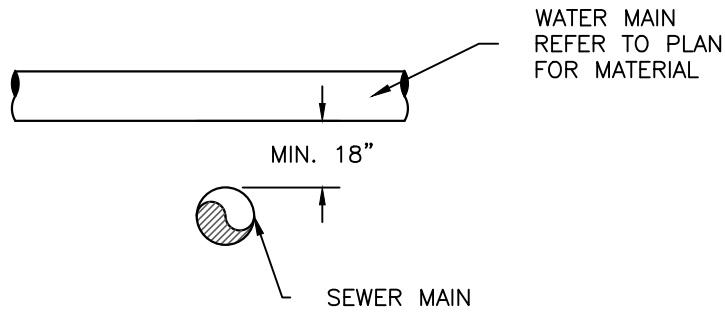

OPTION 1

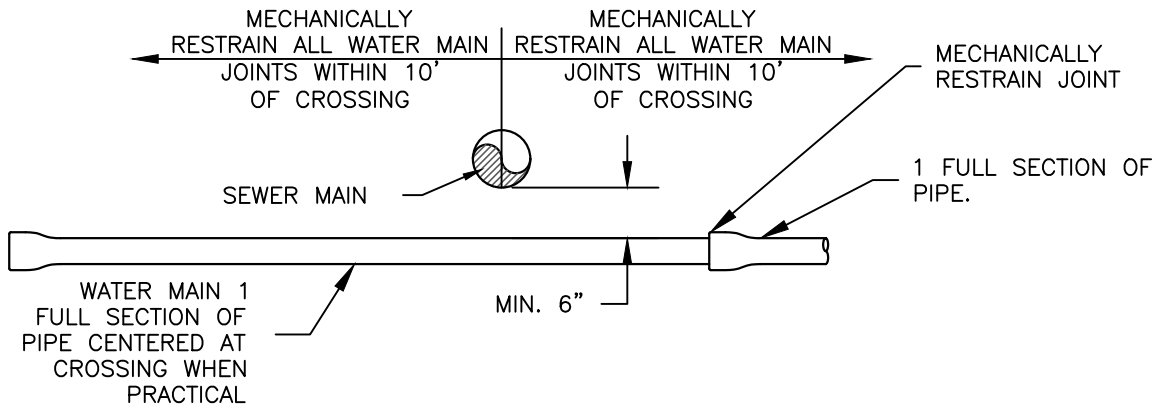

-- OR --

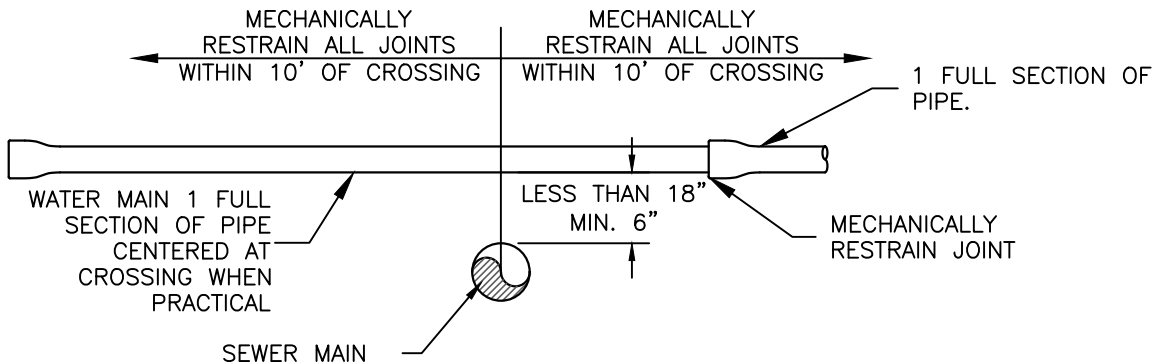

OPTION 2

NOTES:

1. OPTION 1 SHOULD BE UTILIZED WHEN POSSIBLE.
2. NON-PRESSURIZED SEWER MAINS SHALL BE SDR 35 PVC. IF SEWER MAINS ARE NON SDR 35 PVC, SEWER MAINS SHALL BE ENCASED IN 4" OF EXCAVATABLE SLURRY, USE EXTERNAL JOINT SEALANT OR OTHER MITIGATION TO ENSURE JOINTS ARE WATERTIGHT. WHERE THE SEWER MAINS ARE PRESSURIZED THE SEWER MAINS SHALL HAVE MECHANICALLY RESTRAINED JOINTS OR SHALL USE WELDED OR FUSED PIPE.

SOURCE: TMWA DETAIL 10L-11



DRAWN: \_\_\_\_\_ NT  
 CHECKED: \_\_\_\_\_ CLR  
 REV: \_\_\_\_\_ MAY 2024  
 REV: \_\_\_\_\_

STANDARD DETAIL

WATER

WATER MAIN CROSSING  
 SEWER MAIN

2.21.4

**WATER MAIN OR WATER SERVICE LATERAL PARALLEL TO SEWER SERVICE LATERAL**

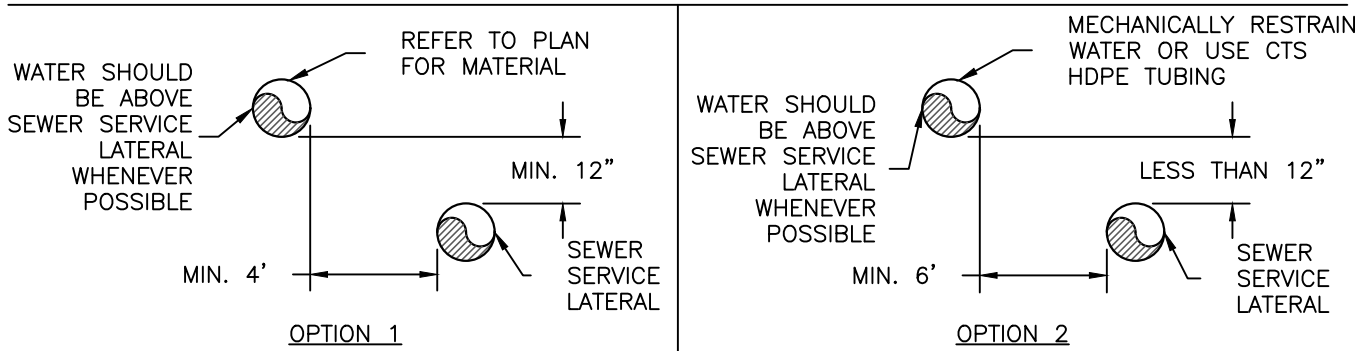

**WATER MAIN OR WATER SERVICE LATERAL CROSSING SEWER SERVICE LATERALS**

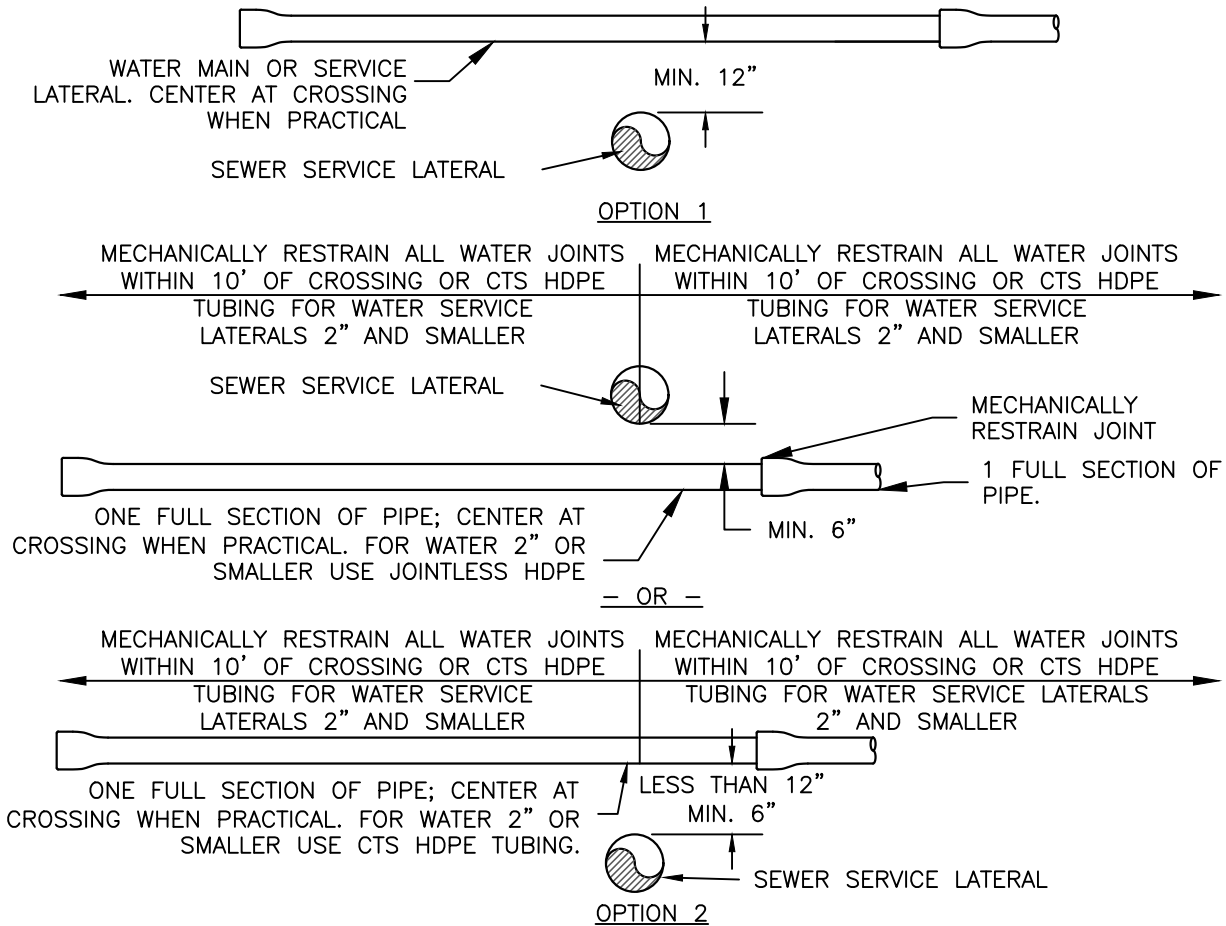

**NOTES:**

- OPTION 1 SHOULD BE UTILIZED WHEN POSSIBLE.
- NON-PRESSURIZED SEWER SERVICE LATERALS SHALL BE SDR 35 PVC. IF SEWER SERVICE LATERALS ARE NON SDR 35 PVC, SEWER SERVICE LATERALS SHALL BE ENCASED IN 4" OF EXCAVATABLE SLURRY, USE EXTERNAL JOINT SEALANT OR OTHER MITIGATION TO ENSURE JOINTS ARE WATERTIGHT. WHERE THE SEWER SERVICE LATERALS ARE PRESSURIZED, THE SEWER SERVICE LATERALS SHALL HAVE MECHANICALLY RESTRAINED JOINTS OR SHALL USE WELDED OR FUSED PIPE.
- FOR WATER SERVICE LATERALS 2" AND SMALLER THERE SHALL BE NO JOINTS OR FITTINGS BETWEEN THE WATER MAIN AND THE WATER METER.

SOURCE: TMWA DETAIL 10L-12



DRAWN: \_\_\_\_\_ NT  
 CHECKED: \_\_\_\_\_ CLR  
 REV: \_\_\_\_\_ MAY 2024  
 REV: \_\_\_\_\_

STANDARD DETAIL	WATER
WATER MAIN OR LATERAL PARALLEL TO OR CROSSING SEWER SERVICE LATERAL	2.21.5

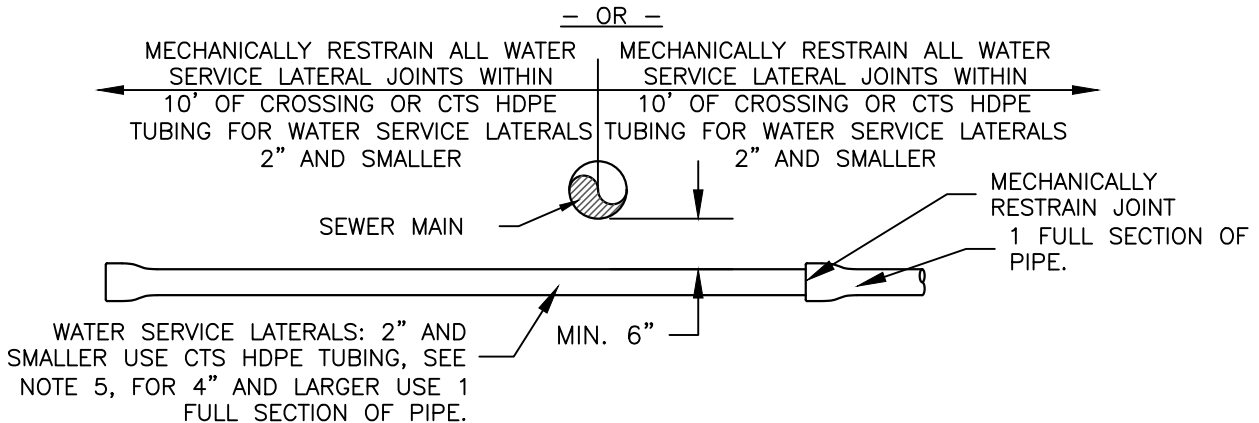
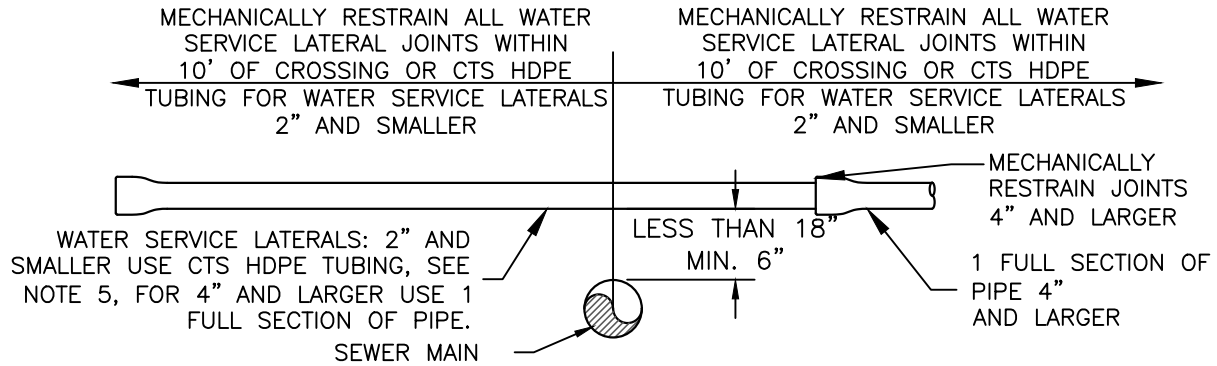
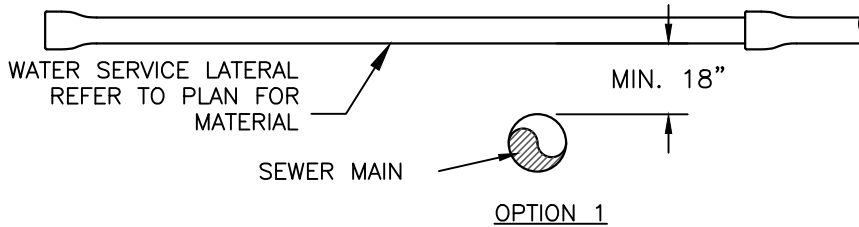

OPTION 2

NOTES:

1. OPTION 1 SHOULD BE UTILIZED WHEN POSSIBLE.
2. NON-PRESSURIZED SEWER MAINS SHALL BE SDR 35 PVC. IF SEWER MAINS ARE NON SDR 35 PVC, SEWER MAINS SHALL BE ENCASED IN 4" OF EXCAVATABLE SLURRY, USE EXTERNAL JOINT SEALANT OR OTHER MITIGATION TO ENSURE JOINTS ARE WATERTIGHT. WHERE THE SEWER MAINS ARE PRESSURIZED, THE SEWER MAINS SHALL HAVE MECHANICALLY RESTRAINED JOINTS OR SHALL USE WELDED OR FUSED PIPE.
3. FOR WATER SERVICE LATERALS 2" AND SMALLER THERE SHALL BE NO JOINTS OR FITTINGS BETWEEN THE WATER MAIN AND THE WATER METER.

SOURCE: TMWA DETAIL 10L-13



DRAWN: \_\_\_\_\_ NT  
 CHECKED: \_\_\_\_\_ CLR  
 REV: \_\_\_\_\_ MAY 2024  
 REV: \_\_\_\_\_

STANDARD DETAIL

WATER SERVICE LATERAL  
 CROSSING SEWER MAIN

WATER

2.21.6

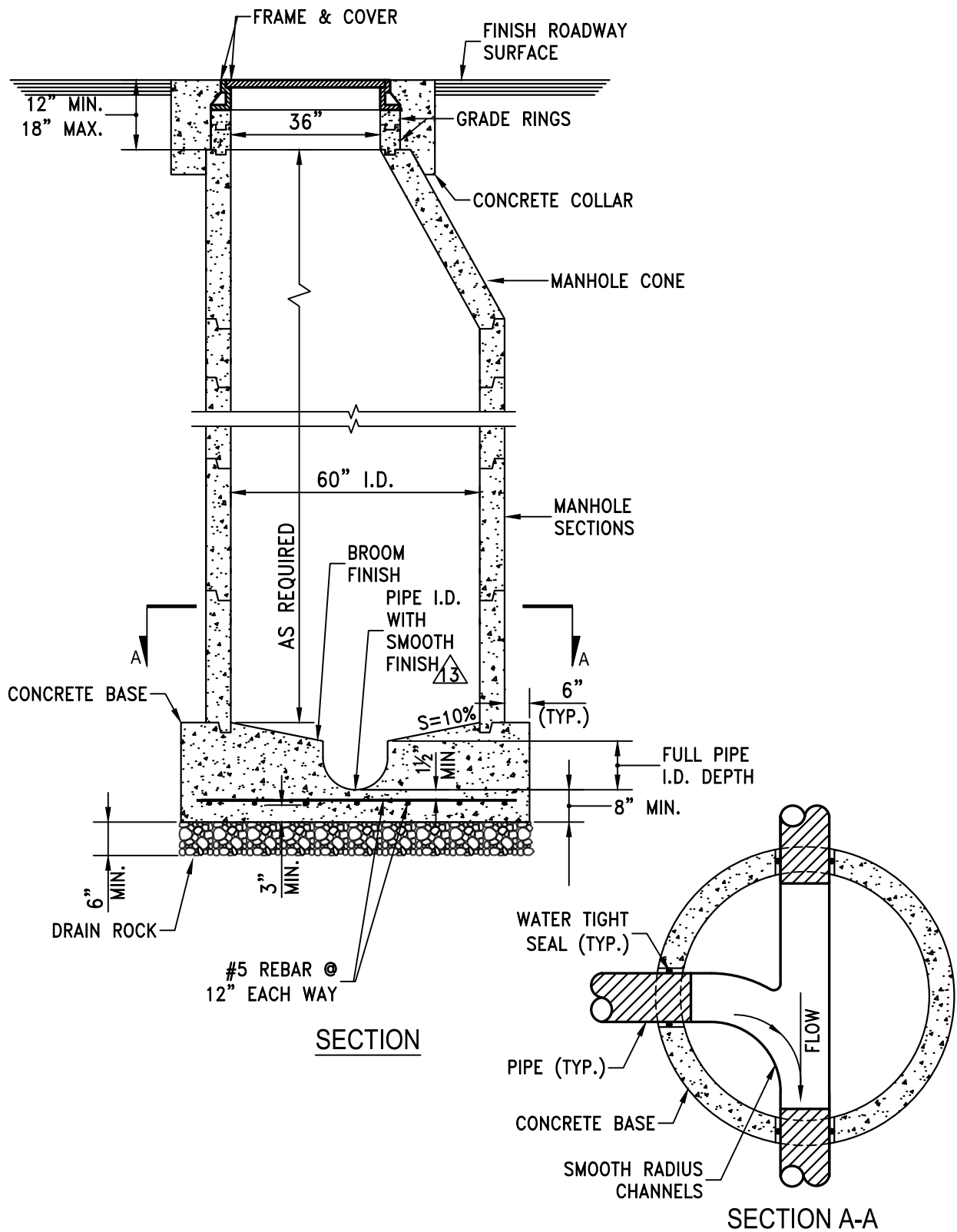

SOURCE: CITY OF RENO DETAIL R-208B



DRAWN: \_\_\_\_\_ NT  
 CHECKED: \_\_\_\_\_ CLR  
 REV: \_\_\_\_\_ MAY 2024  
 REV: \_\_\_\_\_

STANDARD DETAIL

SEWER

36" MANHOLE TYPE V

3.1.1

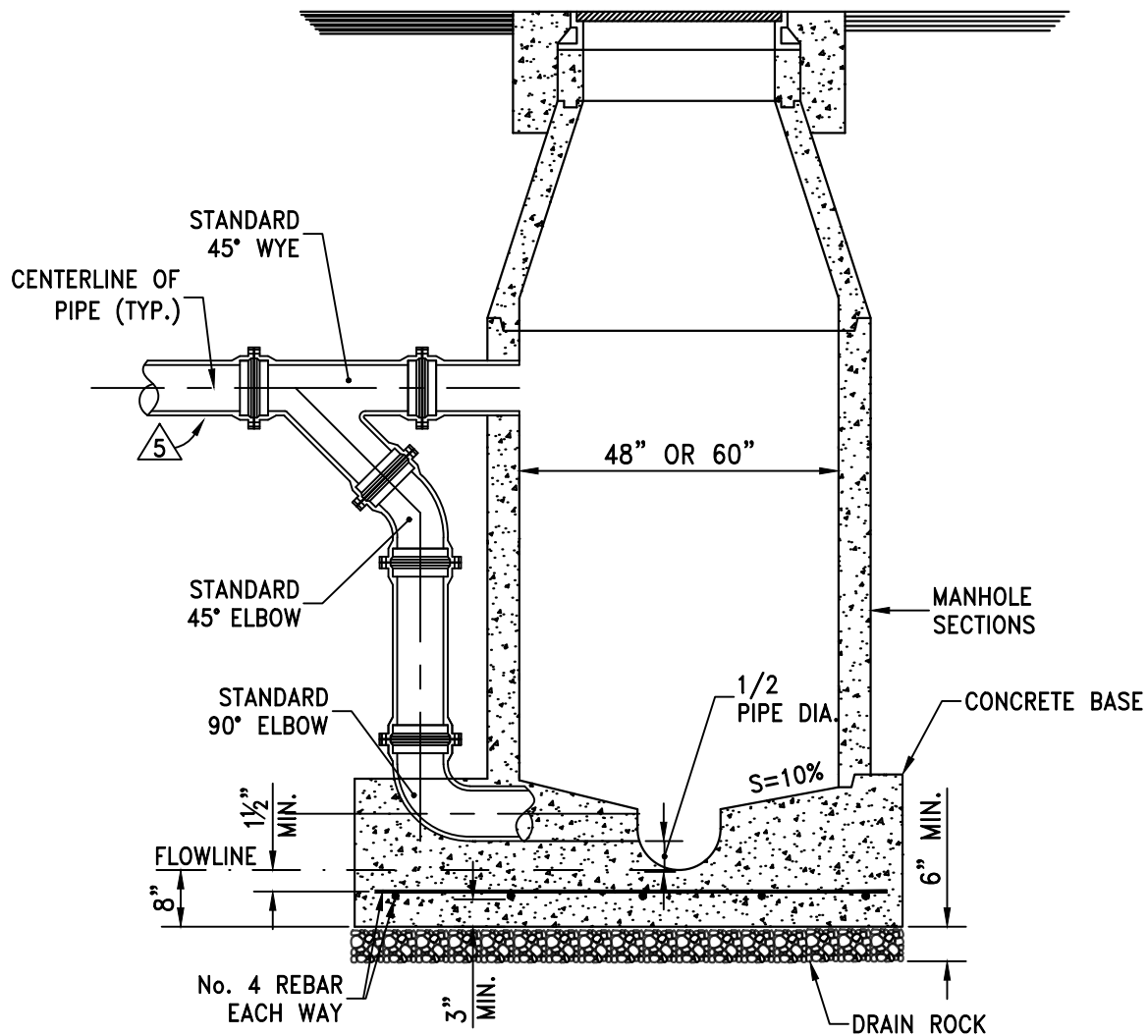

1. DETAIL FOR OUTSIDE DROP ASSEMBLY ONLY. FOR DIMENSIONS, NOTES AND DETAILS NOT SHOWN, REFER TO THE APPLICABLE STANDARD DETAIL DRAWING.
2. CONSTRUCTION OF AN OUTSIDE DROP MANHOLE MUST BE APPROVED IN WRITING BY THE GID ENGINEER IN ADVANCE OF ANY CONSTRUCTION.
3. OUTSIDE DROP MANHOLES ARE TO BE USED ON SANITARY SEWERS WITH MORE THAN 2 FEET VERTICAL DROP AT THE MANHOLE, NOT TO EXCEED 8 FEET, UNLESS OTHERWISE APPROVED BY THE TRIGID ENGINEER.
4. SANITARY SEWER PIPE COMPONENTS OF THE OUTSIDE DROP CONFIGURATION SHALL BE DUCTILE IRON PIPE WITH MECHANICAL JOINT FITTINGS PER AWWA A21.51-02.
5. INSTALL ONE FULL LENGTH OF DUCTILE IRON PIPE (MIN. LENGTH 20') BEYOND THE UPSTREAM END OF THE STANDARD 45° WYE.
6. DUCTILE IRON MATERIAL TO BE LINED AND COATED PER AWWA A21.51-02.

SOURCE: CITY OF RENO DETAIL R-209

 <p>440 USA PKWY, SUITE 105 McCARRAN, NEVADA 89437</p>	DRAWN: _____ NT CHECKED: _____ CLR REV: _____ MAY 2024 REV: _____	STANDARD DETAIL	SEWER
		<h1>DROP MANHOLE</h1>	<h2>3.3.1</h2>



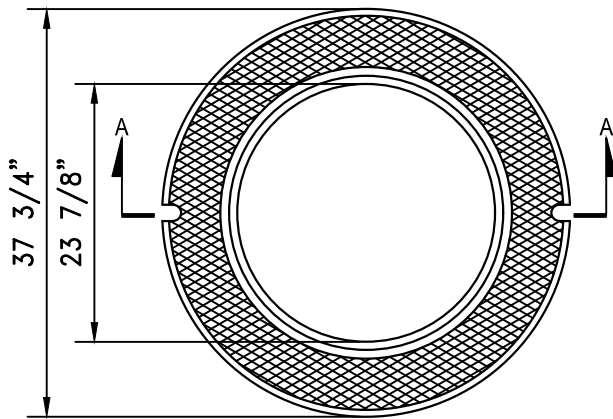

24" COVER ADAPTOR PLAN - TOP

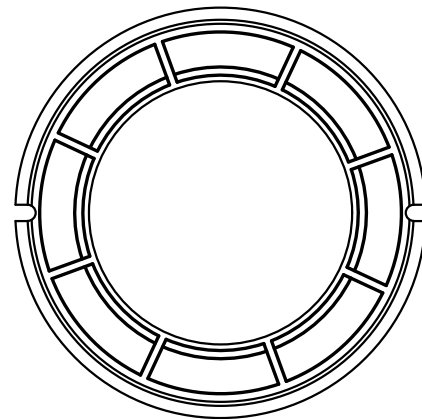

24" COVER ADAPTOR PLAN - BOTTOM

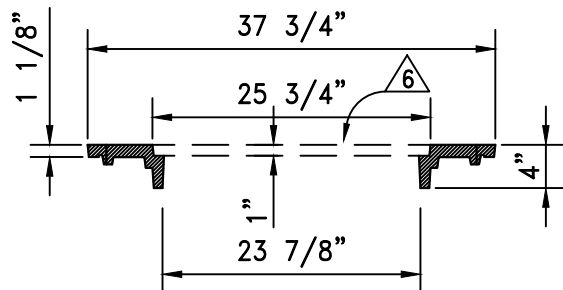

SECTION A-A

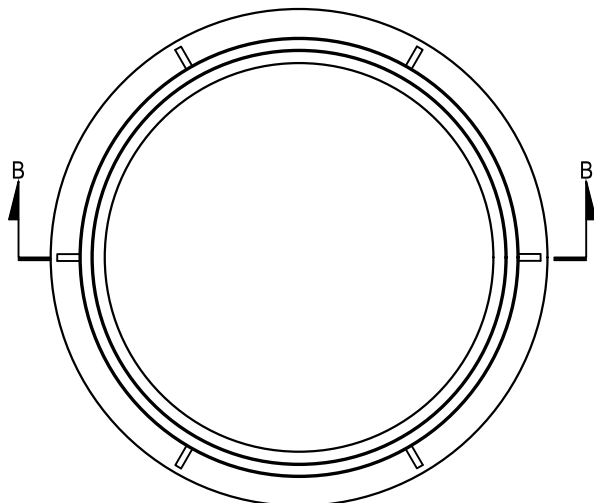

36" MANHOLE FRAME

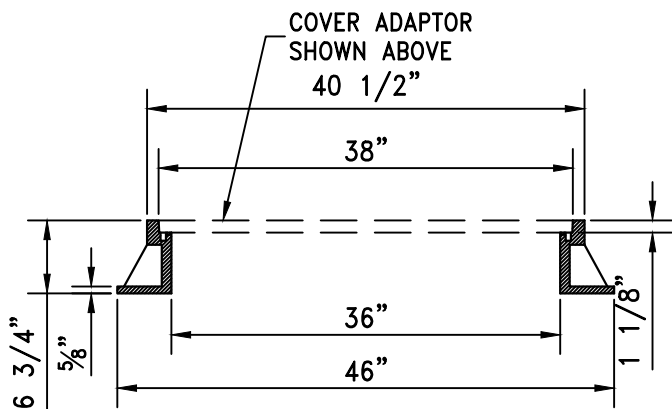

SECTION B-B

**36" FRAME AND COVER ADAPTOR NOTES:**

1. 24" COVER ADAPTOR SHALL BE D&L FOUNDRY A1462-R5, TO ACCEPT D&L FOUNDRY A1032 TRIGID MANHOLE COVERS AND TO SET IN D&L FOUNDRY A1462 TRIGID FRAME OR APPROVED EQUAL.
  2. 36" MANHOLE FRAME SHALL BE D&L FOUNDRY A1462 TRIGID FRAME OR APPROVED EQUAL.
  3. CASTINGS SHALL BE CAST GRAY IRON, AND MEET THE REQUIREMENTS OF ASTM A-48, CLASS 35B, NO PAINT.
  4. FURNISHED WITH MACHINED HORIZONTAL BEARING SURFACE.
  5. MANHOLE COVER ADAPTOR SHALL BE FREE OF HOOKS OR PROTRUSIONS THAT MAY HINDER REMOVAL.
- △6 FOR A1032 TRIGID LOGO COVER, SEE 24" MANHOLE FRAME AND COVER DETAIL (COVER ONLY).

SOURCE: CITY OF RENO DETAIL R-214B



DRAWN: \_\_\_\_\_ NT  
 CHECKED: \_\_\_\_\_ CLR  
 REV: \_\_\_\_\_ MAY 2024  
 REV: \_\_\_\_\_

STANDARD DETAIL

SEWER

MANHOLE FRAME AND  
COVER ADAPTER

3.4.1

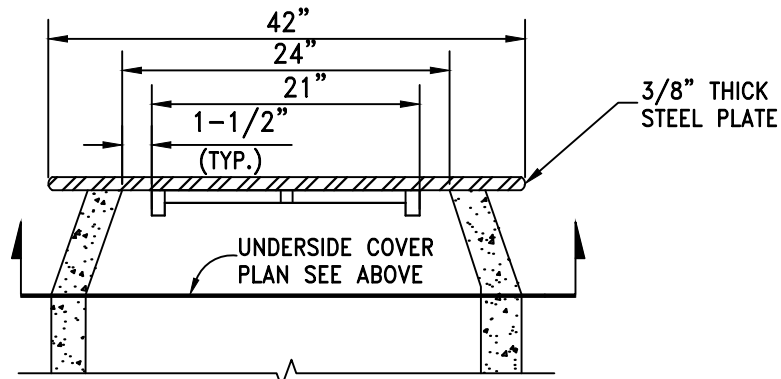
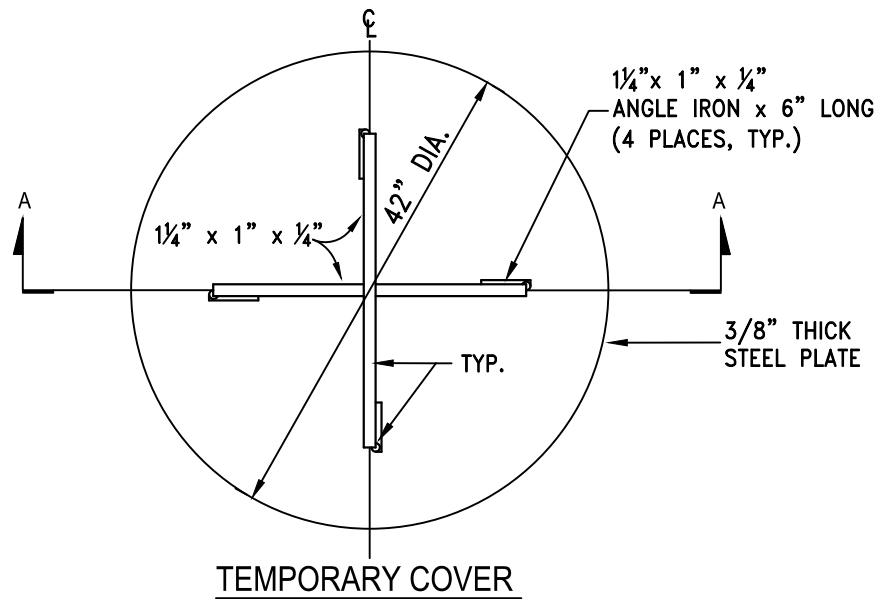

SECTION A-A

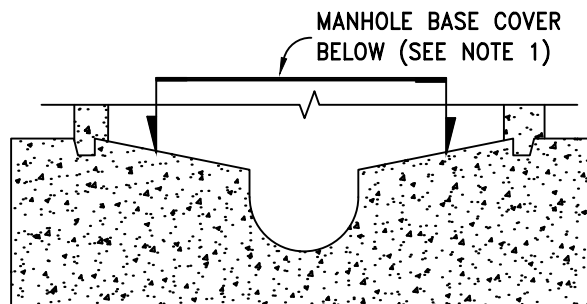

NOTES:

1. INSTALL TEMPORARY COVER WITH CONE INSTALLATION WHEN INSTALLING NEW MANHOLE OR PRIOR TO REMOVING EXISTING FRAME & COVER AND GRADE RINGS TO ADJUST TO FINISH GRADE. INSTALL COVER OVER MANHOLE BASE TO PREVENT DEBRIS FROM ENTERING SEWER SYSTEM. THE MANHOLE BASE COVER SHALL BE IN PLACE PRIOR TO PERFORMING ANY ADJUSTMENTS OR GROUTING AND SHALL REMAIN IN PLACE WHILE ADJUSTMENTS OR GROUTING ARE BEING PERFORMED. REMOVE BASE COVER UPON ADJUSTMENT APPROVAL BY TRIGID.

SOURCE: CITY OF RENO DETAIL R-214C



DRAWN: \_\_\_\_\_ NT  
 CHECKED: \_\_\_\_\_ CLR  
 REV: \_\_\_\_\_ MAY 2024  
 REV: \_\_\_\_\_

STANDARD DETAIL

**TEMPORARY MANHOLE  
COVER**

SEWER

3.5.1

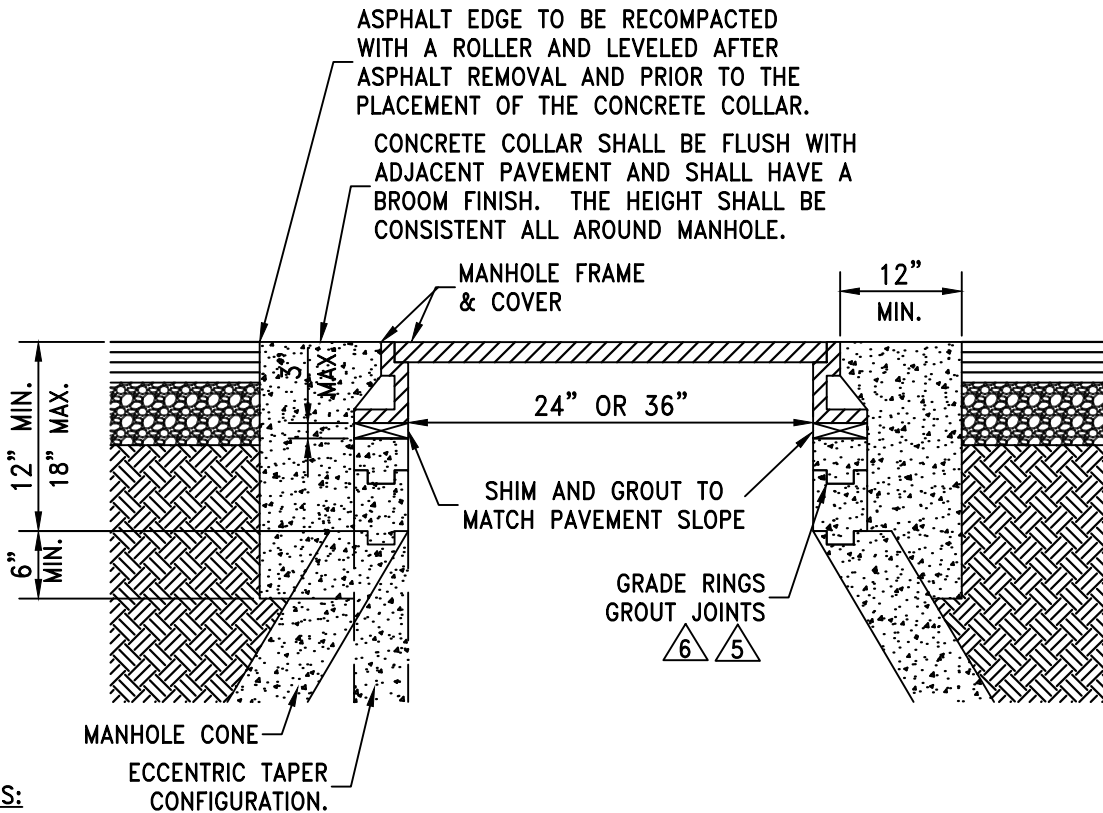

**NOTES:**

1. PORTLAND CEMENT CONCRETE (P.C.C.) SHALL BE 4000 PSI MIN. COMPRESSIVE STRENGTH AT 28 DAYS. ALL CEMENT CONCRETE SHALL HAVE A COARSE AGGREGATE GRADATION CONFORMING TO SIZE No. 67. POLYPROPYLENE OR CELLULOSE FIBERS SHALL BE ADDED TO THE P.C.C. AT 1.5 LBS PER CUBIC YARD. MIX DESIGN SHALL CONFORM TO THE REQUIREMENTS OF SECTION 337.10 OF SSPWC. ALL MATERIALS SHALL CONFORM TO SSPWC.
2. CIRCUMSTANCES MAY REQUIRE THE NEED FOR SPECIAL TYPES OF TOP OF MANHOLE CONFIGURATIONS SUCH AS FLAT TOP, ABOVE GROUND, ETC. AS DIRECTED BY TRIGID. DETAILED PLANS OF ANY SPECIAL TOP OF MANHOLE CONFIGURATIONS AND ASSOCIATED COLLARS MUST BE APPROVED BY THE ENGINEER.
3. IN UNPAVED AREAS, IT SHALL BE NECESSARY TO SET THE MANHOLE RIM APPROXIMATELY 6 INCHES ABOVE THE SURROUNDING AREA. INSTALL A 6 INCH THICK RING OF CONCRETE, TAPERED AT A 3:1 SLOPE, FROM THE TOP, OUTSIDE EDGE OF THE COLLAR TO THE EXISTING GROUND SURFACE.
4. EXISTING SANITARY SEWER MANHOLE LIDS LOCATED IN GUTTER PANS, SHALL HAVE NEW WATER TIGHT FRAMES AND COVERS.
5. ALL GRADE RING JOINTS ARE TO BE GROUTED WITH NON-SHRINK GROUT HAVING THE FOLLOWING CHARACTERISTICS: 3000 PSI MIN. COMPRESSIVE STRENGTH AT 28 DAYS, MIN. 6 SACKS OF CEMENT PER CUBIC YARD AND SLUMP AT 1 TO 4 INCHES. ALL MATERIAL SHALL CONFORM TO SSPWC.
6. ALL GRADE RINGS SHALL BE PORTLAND CEMENT CONCRETE. PVC GRADE RINGS ARE NOT ALLOWED.

SOURCE: CITY OF RENO DETAIL R-218A

 <p>440 USA PKWY, SUITE 105 McCARRAN, NEVADA 89437</p>	DRAWN: _____ NT CHECKED: _____ CLR REV: _____ MAY 2024 REV: _____	STANDARD DETAIL	SEWER
	<h1>MANHOLE COLLAR</h1>		<h2>3.6.1</h2>

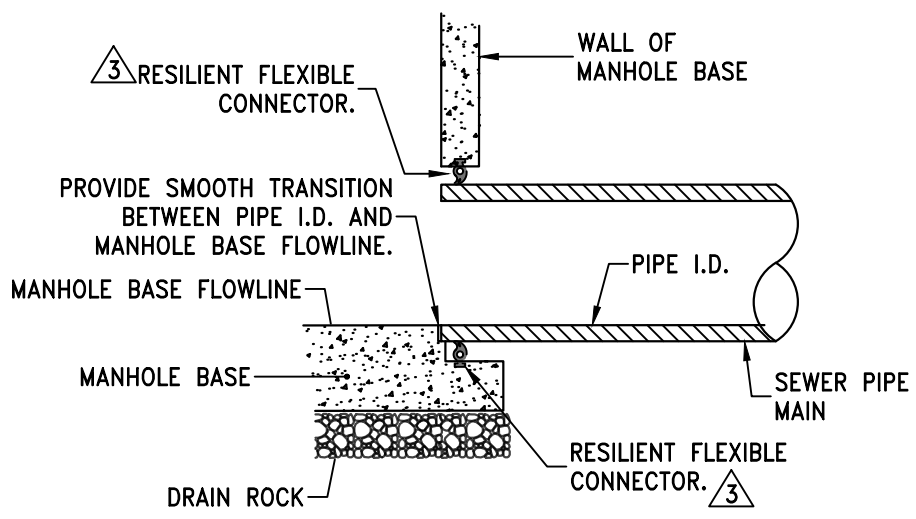
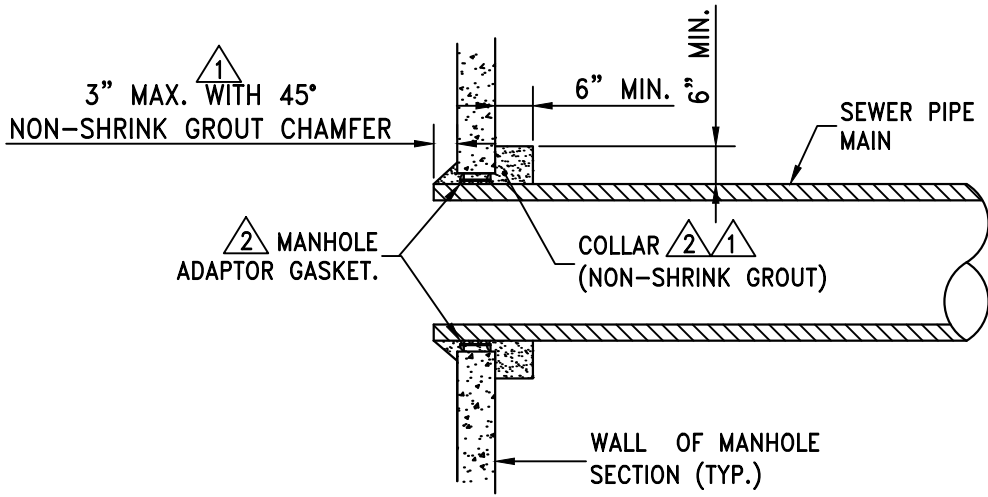

**SECTION**

**NOTES:**

- 1. NON-SHRINK GROUT SHALL HAVE THE FOLLOWING CHARACTERISTICS: 3000 PSI MIN. COMPRESSIVE STRENGTH AT 28 DAYS, MIN. 6 SACKS OF CEMENT PER CUBIC YARD AND SLUMP AT 1 TO 4 INCHES. ALL MATERIAL SHALL CONFORM TO STANDARD SPECIFICATIONS OF PUBLIC WORKS CONSTRUCTION (SSPWC) SECTION 202.
- 2. SANITARY SEWER PIPE CONNECTION TO MANHOLE SECTIONS (DROP MANHOLES) REQUIRE AN AGENCY-APPROVED FORM OF SEAL OR WATER STOP TO PROVIDE A WATERTIGHT CONNECTION. UTILIZE A ROMAC STYLE "LCT" MANHOLE ADAPTOR GASKET OR APPROVED EQUAL IN CONJUNCTION WITH NON-SHRINK GROUT.
- 3. SANITARY SEWER PIPE CONNECTION TO MANHOLE BASE SHALL REQUIRE A RESILIENT FLEXIBLE CONNECTOR INSTALLED IN ACCORDANCE WITH STANDARD DETAIL 3.8.
- 4. ALL PIPE OPENINGS TO NEW MANHOLES MUST BE EITHER CAST-IN-PLACE OR PRE-FORMED AND PIPE OPENINGS TO EXISTING MANHOLES MUST BE CORE DRILLED.

SOURCE: CITY OF RENO DETAIL R-223A



DRAWN: \_\_\_\_\_ NT  
 CHECKED: \_\_\_\_\_ CLR  
 REV: \_\_\_\_\_ MAY 2024  
 REV: \_\_\_\_\_

STANDARD DETAIL

**SEWER PIPE TO  
MANHOLE CONNECTION**

SEWER

3.7.1

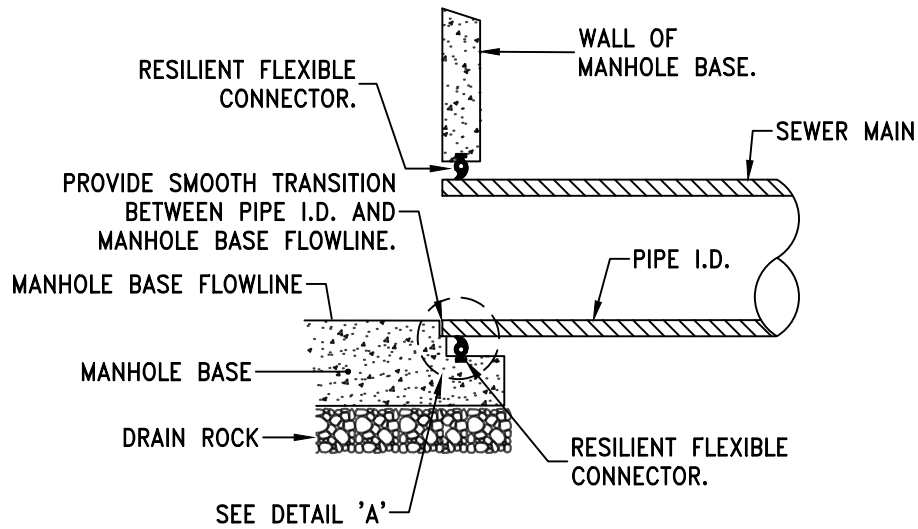

SECTION

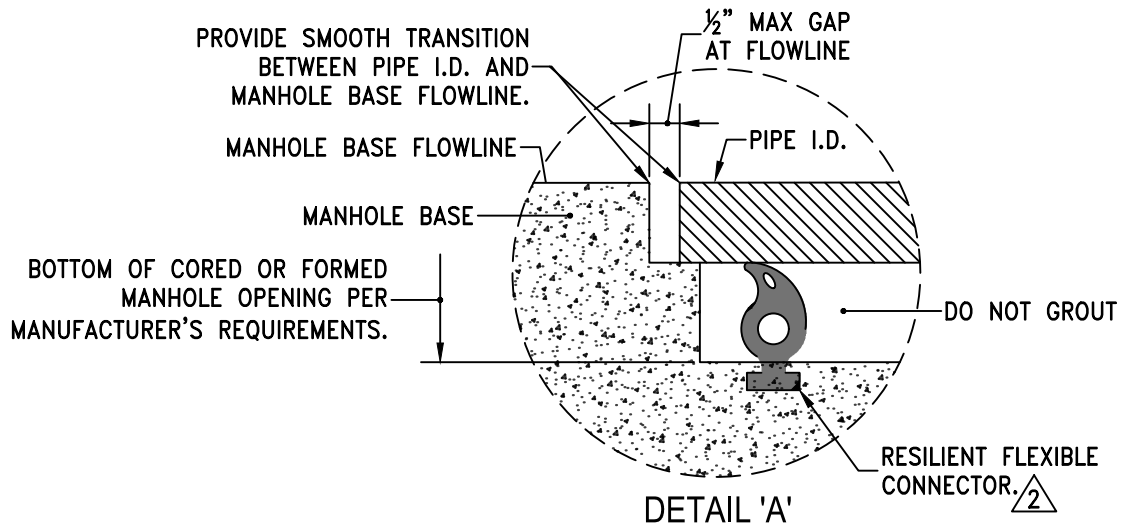

**NOTES:**

1. A SEAL OR WATER STOP IS REQUIRED ON ALL SANITARY SEWER INSTALLATIONS AND IN OTHER APPLICATIONS AS REQUIRED BY TRIGID TO PROVIDE A WATERTIGHT CONNECTION.
2. A RESILIENT FLEXIBLE CONNECTOR PER ASTM C 923-89 SHALL BE USED AT THE MANHOLE/PIPE CONNECTION TO SATISFY THE REQUIREMENTS OF NOTE 1. FOR PRE-CAST CONCRETE STRUCTURES, THE RESILIENT FLEXIBLE CONNECTOR SHALL BE AN "A-LOK" TYPE PIPE-TO-MANHOLE CONNECTOR OR APPROVED EQUAL. FOR CAST-IN-PLACE STRUCTURES, THE RESILIENT FLEXIBLE CONNECTOR SHALL BE A "KOR-N-SEAL I - TOGGLE KORBAND" TYPE PIPE-TO-MANHOLE CONNECTOR OR APPROVED EQUAL.
3. THE INTERIOR MANHOLE CONNECTION SHALL HAVE A SMOOTH TRANSITION BETWEEN PIPE I.D. AND MANHOLE BASE FLOWLINE. NO GROUT OR CONCRETE SHALL BE PLACED AROUND THE RESILIENT FLEXIBLE CONNECTOR.

SOURCE: CITY OF RENO DETAIL R-223C



DRAWN: \_\_\_\_\_ NT  
 CHECKED: \_\_\_\_\_ CLR  
 REV: \_\_\_\_\_ MAY 2024  
 REV: \_\_\_\_\_

STANDARD DETAIL

SEWER

RESILIENT FLEXIBLE  
 CONNECTOR

3.8.1

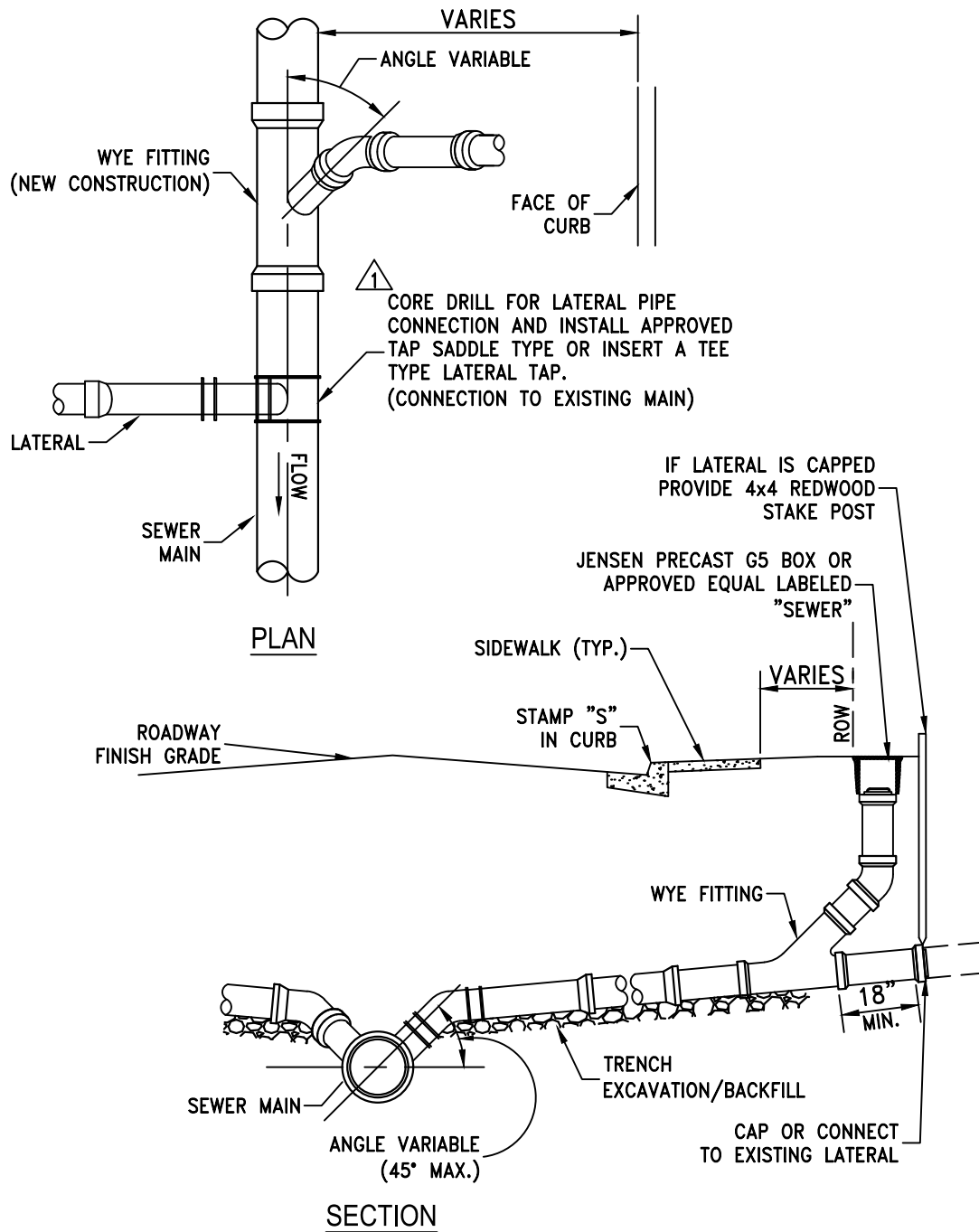

**NOTES:**

1. USE OF SEWER SERVICE TAP SADDLE CONNECTIONS SHALL NOT BE ALLOWED FOR NEW SEWER MAIN CONSTRUCTION. WHEN A TAP SADDLE CONNECTION IS TO BE USED ON AN EXISTING SEWER MAIN, IT SHALL BE A WYE SADDLE AND BE INSTALLED PER DETAIL 3.10.

SOURCE: CITY OF RENO DETAIL R-224A



DRAWN: \_\_\_\_\_ NT  
 CHECKED: \_\_\_\_\_ CLR  
 REV: \_\_\_\_\_ MAY 2024  
 REV: \_\_\_\_\_

STANDARD DETAIL

SEWER

SEWER LATERAL

3.9.1

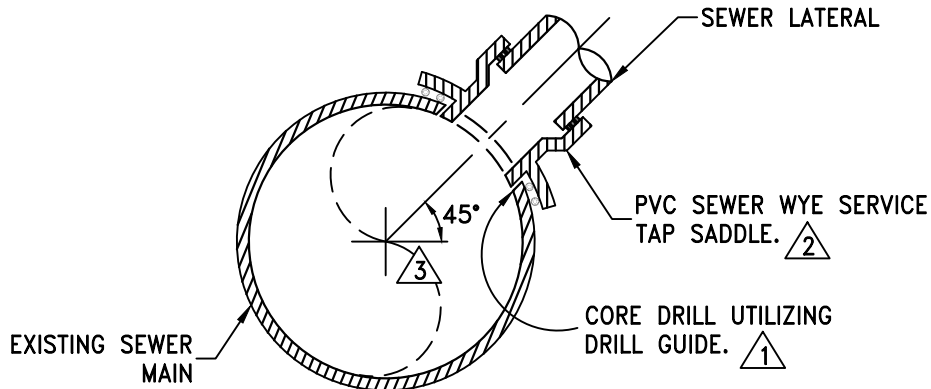

**SECTION A-A**

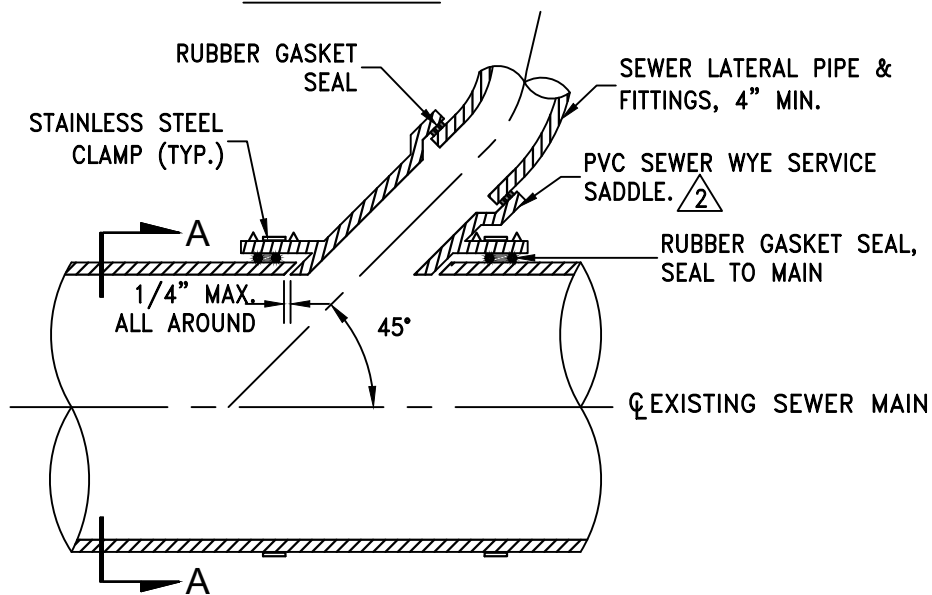

**SIDE VIEW**

**NOTES:**

- 1. EXISTING SEWER MAINS SHALL BE CORE DRILLED UTILIZING A DRILL GUIDE FOR A WYE SADDLE AND A CORE DRILL WITH A LENGTH EXCEEDING THE LATERAL DIAMETER, INSERT-A-DRILL IDY75 & EXTRA LONG HOLE SAW OR APPROVED EQUAL. DIAMOND CORE BITS SHALL BE USED ON NON-PVC MAINS.
- 2. SERVICE TAP SADDLES SHALL BE PVC SEWER WYE SADDLES. A ROMAC STYLE "CB" SEWER SADDLE OR APPROVED EQUAL MAY BE USED ON EXISTING SEWER MAINS ONLY WHEN MAIN IS NOT PVC.
- 3. SADDLES SHALL BE INSTALLED AT 45 DEGREES TO MAIN AS SHOWN IN SECTION A-A. IN NO CASE SHALL A LATERAL CONNECTING TO THE EXISTING SEWER MAIN BE LOCATED DIRECTLY ON TOP OF THE PIPE, NOR SHALL IT MATCH THE FLOWLINE OF THE PIPE.

SOURCE: CITY OF RENO DETAIL R-224C

 <p>440 USA PKWY, SUITE 105 McCARRAN, NEVADA 89437</p>	DRAWN: _____ NT CHECKED: _____ CLR REV: _____ MAY 2024 REV: _____	STANDARD DETAIL	SEWER
	SEWER SADDLE TAP		3.10.1



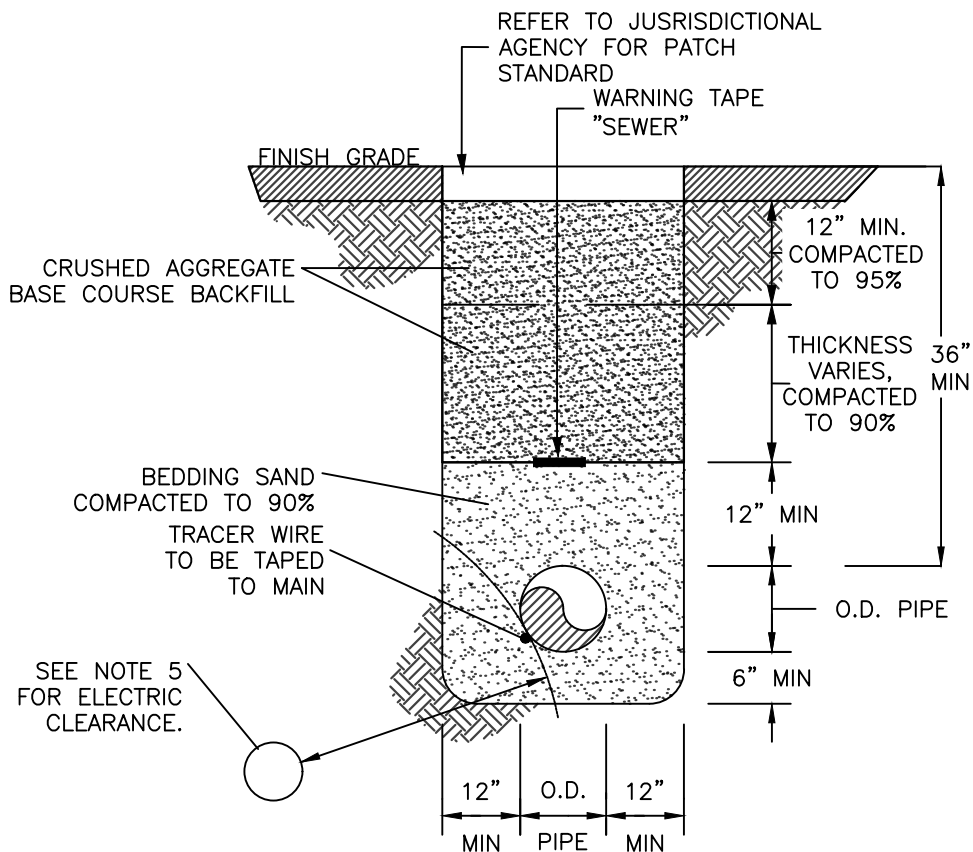

NOTES:

1. ALL TRENCHES MUST CONFORM TO APPLICABLE TRIGID, STATE, COUNTY, AND OSHA SPECIFICATIONS AND REQUIREMENTS. IN THE CASE OF CONFLICT, THE MORE RIGID SPECIFICATION OR STANDARD SHALL APPLY.
2. BEDDING SAND SHALL CONFORM WITH ORANGE BOOK CLASS A REQUIREMENTS, COMPACTED TO 90% MAXIMUM DENSITY, AND SHALL BE A MINIMUM OF 12" ABOVE AND 6" BELOW THE MAIN.
3. CRUSHED AGGREGATE BASE COURSE BACKFILL SHALL CONFORM TO ORANGE BOOK CLASS 2 TYPE B REQUIREMENTS AND BE PLACED IN 12" MAXIMUM LOOSE LIFTS. THE TOP 12" SHALL BE COMPACTED TO 95% MAXIMUM DENSITY. THE AREA ABOVE THE BEDDING SAND & BELOW 12" FROM FINISH GRADE SHALL BE COMPACTED TO 90% MAXIMUM DENSITY.
4. NON-METALLIC BLUE WARNING TAPE SHALL BE PLACED IN ALL TRENCHES AT LEAST 12" ABOVE THE WATER MAIN.
5. ELECTRIC UTILITIES MUST BE LOCATED BELOW WATER & MAINTAIN 2' MINIMUM RADIAL CLEARANCE FROM TRIGID WATER FACILITIES. IF 2' RADIAL CLEARANCE CAN NOT BE MET ELECTRIC CONDUIT MUST BE CONCRETE ENCASED AT LEAST 18" EACH SIDE OF WATER CROSSING. FIBER OPTIC AND/OR COMMUNICATION CONDUITS SHALL NOT BE PLACE IN THE SAME TRENCH AS WATER.
6. ALL CHANGES MUST BE APPROVED BY THE TRIGID INSPECTOR AND/OR THE TRIGID ENGINEER.
7. SEPARATION FOR PIPES IN A JOINT TRENCH SHALL BE A MINIMUM OF 12".
8. TRACER WIRE SHALL BE #14 COPPER CLAD STAINLESS STEEL CORE WITH 30 MILS BLUE HDPE INSULATION. ALL WIRE SPLICES SHALL BE MADE USING A SPLIT BOLT CONNECTOR WRAPPED WITH AQUASEAL AND ELECTRIC TAPE. THE CONTRACTOR SHALL INSTALL A 3 POUND ANODE AT EVERY TEST STATION. TEST STATIONS SHALL BE LOCATED ALONG THE MAIN NO MORE THAN 500 FEET APART. REFER TO SUBSECTION 2.21.2.

SOURCE: TMWA DETAIL 10L-6



DRAWN: \_\_\_\_\_ NT  
 CHECKED: \_\_\_\_\_ CLR  
 REV: \_\_\_\_\_ SEP 2024  
 REV: \_\_\_\_\_

STANDARD DETAIL

SEWER

TRENCH DETAIL -  
SEWER ONLY

3.11.1

NOTES:

1. REFERENCE TRIGID STANDARD DETAIL 5.13 FOR THRUST BLOCK SIZING AND REQUIREMENTS.
2. ALL BOLTS AND EXPOSED METAL SHALL BE COATED WITH BRUSHED-ON MASTIC.
3. TEE, VALVES, FITTINGS, DUCTILE IRON PIPE AND OTHER METAL PARTS SHALL BE ENCASED WITH POLYETHYLENE WRAP PER AWWA C105.
4. CONCRETE FOR PADS SHALL HAVE A COMPRESSIVE STRENGTH OF NOT LESS THAN 3,000 PSI AFTER 28 DAYS. BAG CONCRETE MIX IS NOT ACCEPTABLE.
5. POSITION OF FLG x MJ VALVE (RUN) AND FLG x MJ ADAPTER MAY SWITCH, REFERENCE WATER IMPROVEMENT PLANS.
6. AN ADDITIONAL FLG x MJ VALVE MAY BE REQUIRED IN LIEU OF FLG x MJ ADAPTER, REF. WATER IMPROVEMENT PLANS.

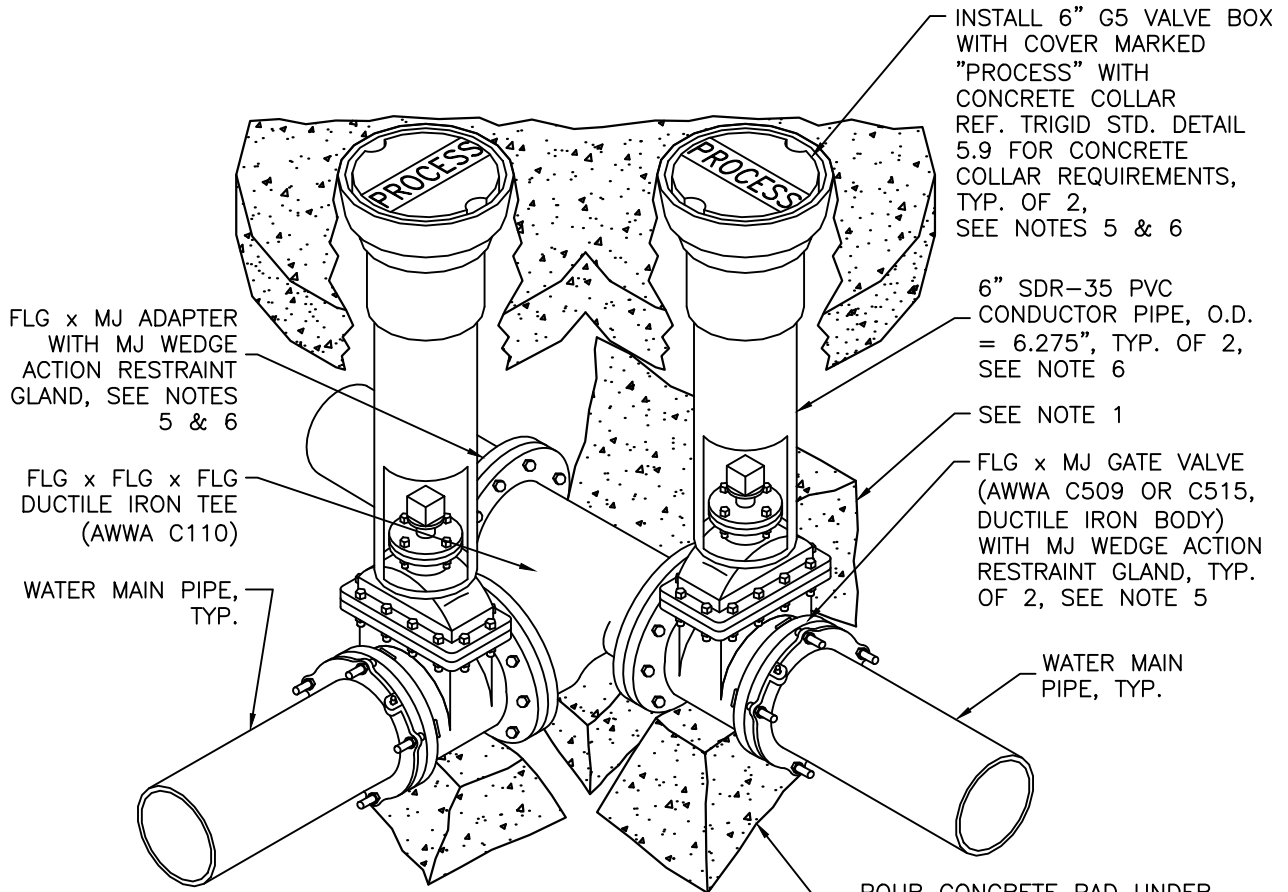

MATERIAL LIST

QTY.	DESCRIPTION
1	FLG x FLG x FLG DUCTILE IRON TEE (AWWA C110)
2	FLG x MJ GATE VALVE WITH DUCTILE IRON BODY (AWWA C509 OR C515)
1	FLG x MJ ADAPTER
3	MJ WEDGE ACTION RESTRAINT GLAND
2	6" G5 VALVE BOX WITH COVER MARKED "PROCESS"
2	6" SDR-35 PVC CONDUCTOR PIPE SECTION, O.D. = 6.275"
-	CONCRETE BULK - THRUST BLOCKS, PADS, COLLARS

SOURCE: TMWA DETAIL 10B-2

 440 USA PKWY, SUITE 105 McCARRAN, NEVADA 89437	DRAWN: _____ NT CHECKED: _____ CLR REV: _____ MAY 2024 REV: _____	STANDARD DETAIL <b>FLANGED TEES</b> <b>FLG x MJ GATE VALVES</b> - RESTRAINED -	PROCESS  <b>5.1.1</b>

NOTES:

1. REFERENCE TRIGID STANDARD DETAIL 5.13 FOR THRUST BLOCK SIZING AND REQUIREMENTS.
2. ALL BOLTS AND EXPOSED METAL SHALL BE COATED WITH BRUSHED-ON MASTIC.
3. TEE, VALVES, FITTINGS, DUCTILE IRON PIPE AND OTHER METAL PARTS SHALL BE ENCASED WITH POLYETHYLENE WRAP PER AWWA C105.
4. CONCRETE FOR PADS SHALL HAVE A COMPRESSIVE STRENGTH OF NOT LESS THAN 3,000 PSI AFTER 28 DAYS. BAG CONCRETE MIX IS NOT ACCEPTABLE.
5. POSITION OF FLG x PO VALVE (RUN) AND FLG x PO ADAPTER MAY SWITCH, REFERENCE WATER IMPROVEMENT PLANS.
6. AN ADDITIONAL FLG x PO VALVE MAY BE REQUIRED IN LIEU OF FLG x PO ADAPTER, REF. WATER IMPROVEMENT PLANS.

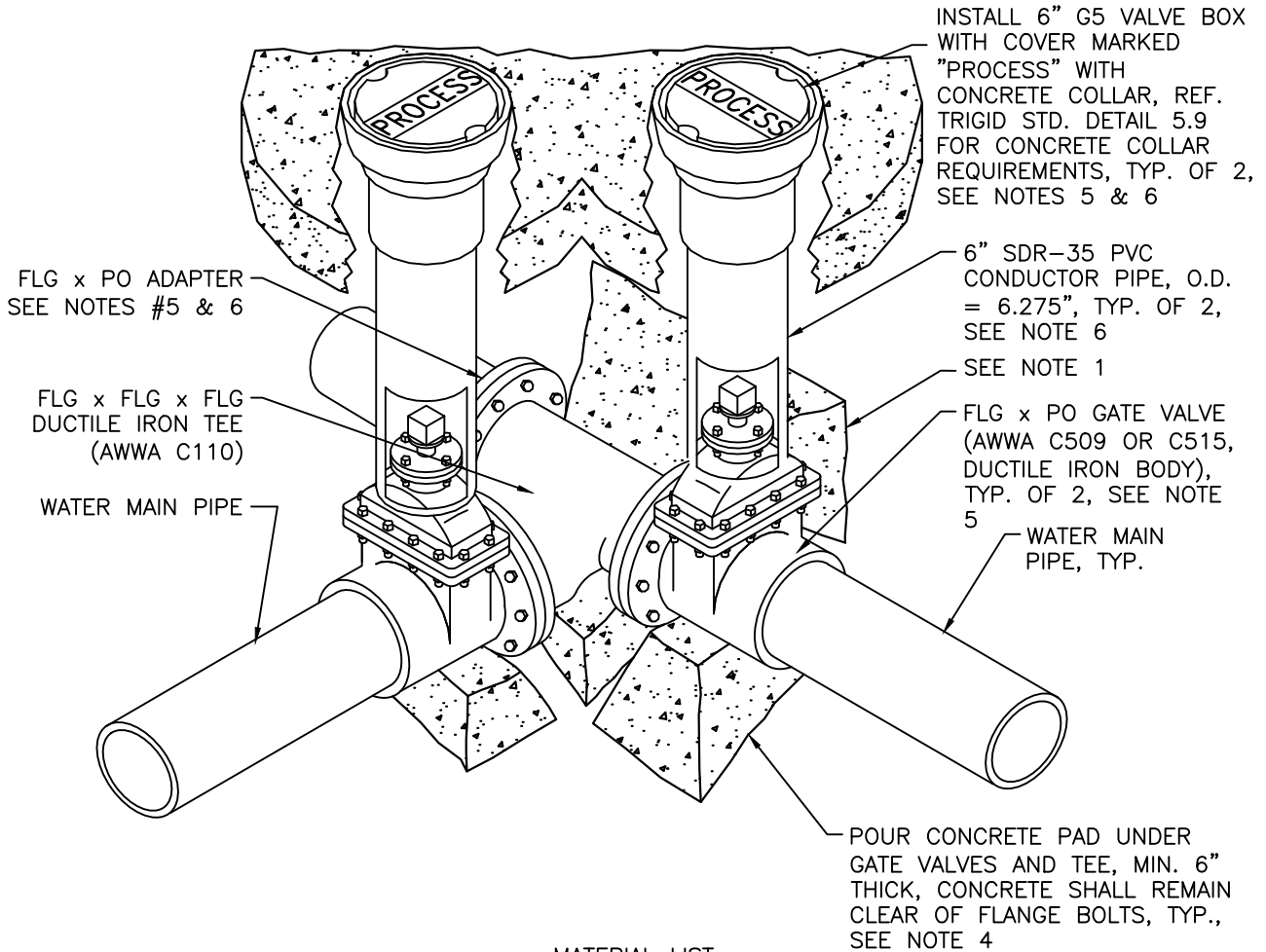

MATERIAL LIST

QTY.	DESCRIPTION
1	FLG x FLG x FLG DUCTILE IRON TEE (AWWA C110)
2	FLG x PO GATE VALVE WITH DUCTILE IRON BODY (AWWA C509 OR C515)
1	FLG x PO ADAPTER
2	6" G5 VALVE BOX WITH COVER MARKED "PROCESS"
2	6" SDR-35 PVC CONDUCTOR PIPE SECTION, O.D. = 6.275"
-	CONCRETE BULK - THRUST BLOCKS, PADS, COLLARS

SOURCE: TMWA DETAIL 10B-3

 <p>440 USA PKWY, SUITE 105 McCARRAN, NEVADA 89437</p>	DRAWN: _____ NT CHECKED: _____ CLR REV: _____ MAY 2024 REV: _____	STANDARD DETAIL	PROCESS
	FLANGED TEES FLG x PO GATE VALVES		5.1.2

NOTES:

1. REFERENCE TRIGID STANDARD DETAIL 5.13 FOR THRUST BLOCK SIZING AND REQUIREMENTS.
2. ALL BOLTS AND EXPOSED METAL SHALL BE COATED WITH BRUSHED-ON MASTIC.
3. TEE, VALVES, FITTINGS, DUCTILE IRON PIPE AND OTHER METAL PARTS SHALL BE ENCASED WITH POLYETHYLENE WRAP PER AWWA C105.
4. CONCRETE FOR PADS SHALL HAVE A COMPRESSIVE STRENGTH OF NOT LESS THAN 3,000 PSI AFTER 28 DAYS. BAG CONCRETE MIX IS NOT ACCEPTABLE.

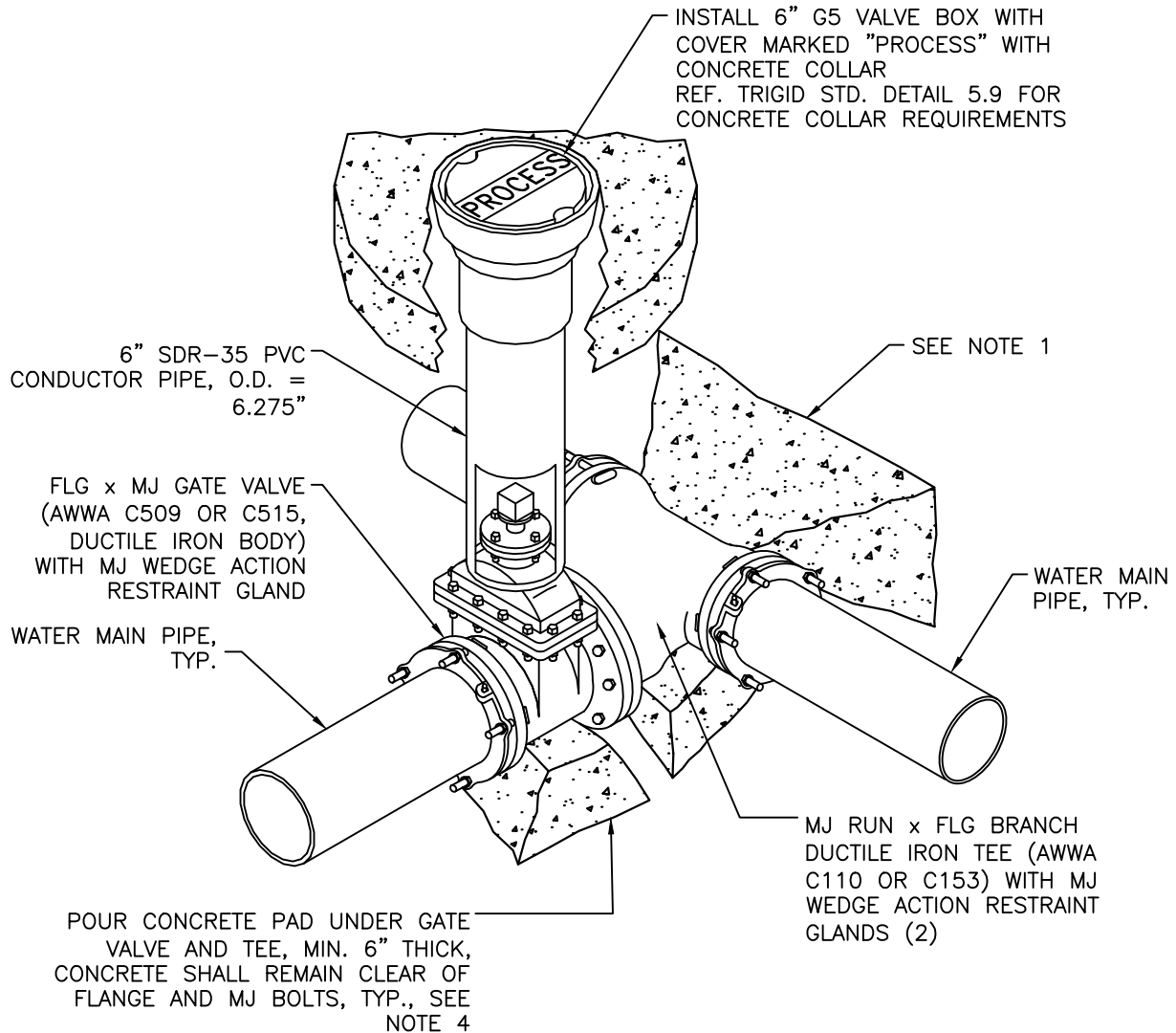

MATERIAL LIST

QTY.	DESCRIPTION
1	MJ RUN x FLG BRANCH DUCTILE IRON TEE (AWWA C110 OR C153)
1	FLG x MJ GATE VALVE WITH DUCTILE IRON BODY (AWWA C509 OR C515)
3	MJ WEDGE ACTION RESTRAINT GLAND
1	6" G5 VALVE BOX WITH COVER MARKED "PROCESS"
1	6" SDR-35 PVC CONDUCTOR PIPE SECTION, O.D. = 6.275"
-	CONCRETE BULK - THRUST BLOCKS, PADS, COLLARS

SOURCE: TMWA DETAIL 10B-4

 <p>440 USA PKWY, SUITE 105 McCARRAN, NEVADA 89437</p>	DRAWN: _____ NT CHECKED: _____ CLR REV: _____ MAY 2024 REV: _____	STANDARD DETAIL <b>MECHANICAL JOINT x FLANGED TEES</b> <b>FLG x MJ GATE VALVE</b> - RESTRAINED -	PROCESS  <b>5.1.3</b>

NOTES:

1. REFERENCE TRIGID STANDARD DETAIL 5.13 FOR THRUST BLOCK SIZING AND REQUIREMENTS.
2. ALL BOLTS AND EXPOSED METAL SHALL BE COATED WITH BRUSHED-ON MASTIC.
3. TEE, VALVES, FITTINGS, DUCTILE IRON PIPE AND OTHER METAL PARTS SHALL BE ENCASED WITH POLYETHYLENE WRAP PER AWWA C105.
4. CONCRETE FOR PADS SHALL HAVE A COMPRESSIVE STRENGTH OF NOT LESS THAN 3,000 PSI AFTER 28 DAYS. BAG CONCRETE MIX IS NOT ACCEPTABLE.

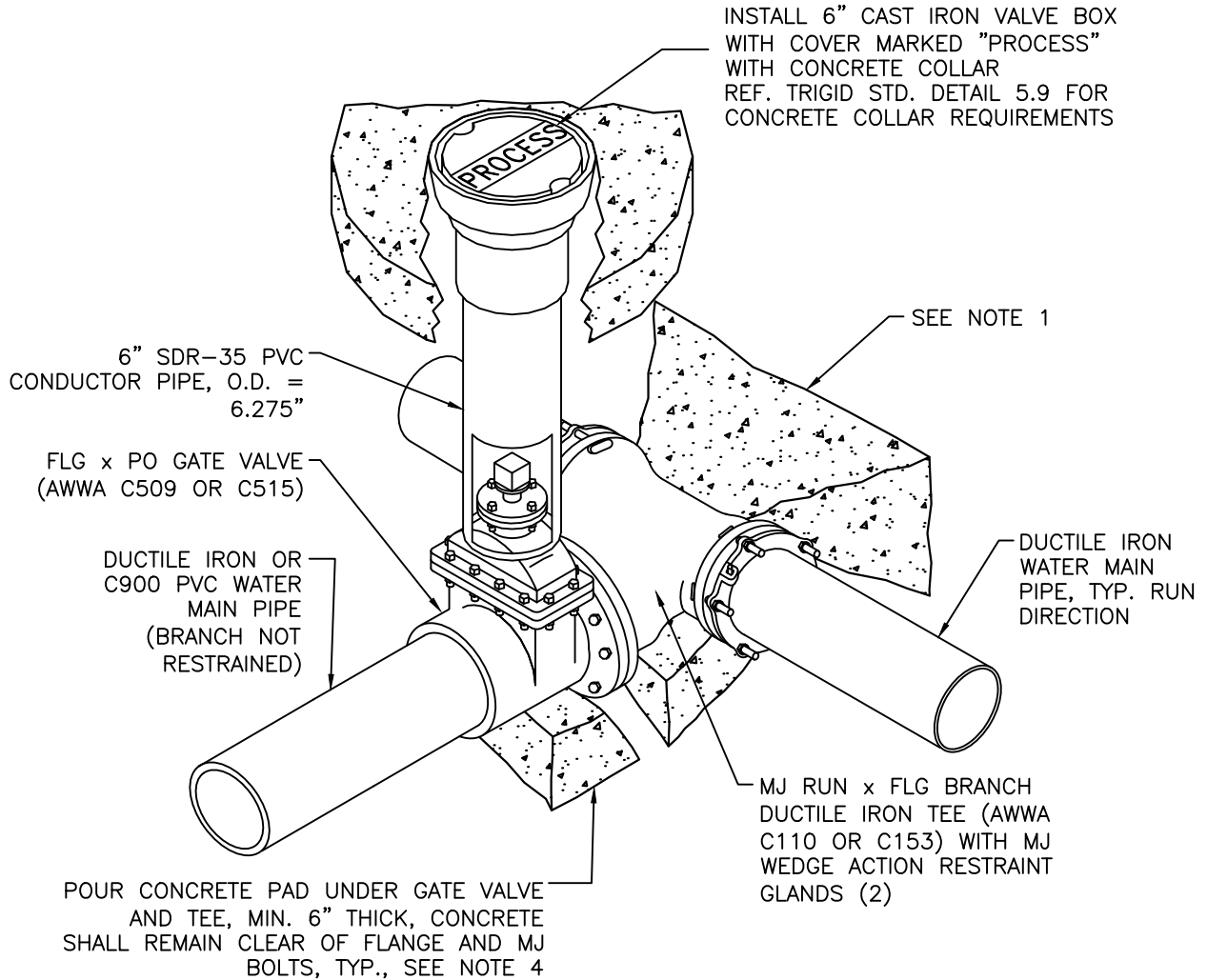

MATERIAL LIST

QTY.	DESCRIPTION
1	MJ RUN x FLG BRANCH DUCTILE IRON TEE (AWWA C110 OR C153)
1	FLG x PO GATE VALVE WITH DUCTILE IRON BODY (AWWA C509 OR C515)
2	MJ WEDGE ACTION RESTRAINT GLAND
1	6" CAST IRON VALVE BOX WITH COVER MARKED "PROCESS"
1	6" SDR-35 PVC CONDUCTOR PIPE SECTION, O.D. = 6.275"
-	CONCRETE BULK - THRUST BLOCKS, PADS, COLLARS

SOURCE: TMWA DETAIL 10B-6



DRAWN: \_\_\_\_\_ NT  
 CHECKED: \_\_\_\_\_ CLR  
 REV: \_\_\_\_\_ AUG. 2024, MAY 2024  
 REV: \_\_\_\_\_

STANDARD DETAIL  
 MECHANICAL JOINT x FLANGED TEES  
 MJ x PO GATE VALVE

PROCESS  
 5.1.4

NOTES:

1. REFERENCE TRIGID STANDARD DETAIL 5.13 FOR THRUST BLOCK SIZING AND REQUIREMENTS.
2. ALL BOLTS AND EXPOSED METAL SHALL BE COATED WITH BRUSHED-ON MASTIC.
3. TEE, VALVES, FITTINGS, DUCTILE IRON PIPE AND OTHER METAL PARTS SHALL BE ENCASED WITH POLYETHYLENE WRAP PER AWWA C105.
4. CONCRETE FOR PADS SHALL HAVE A COMPRESSIVE STRENGTH OF NOT LESS THAN 3,000 PSI AFTER 28 DAYS. BAG CONCRETE MIX IS NOT ACCEPTABLE.

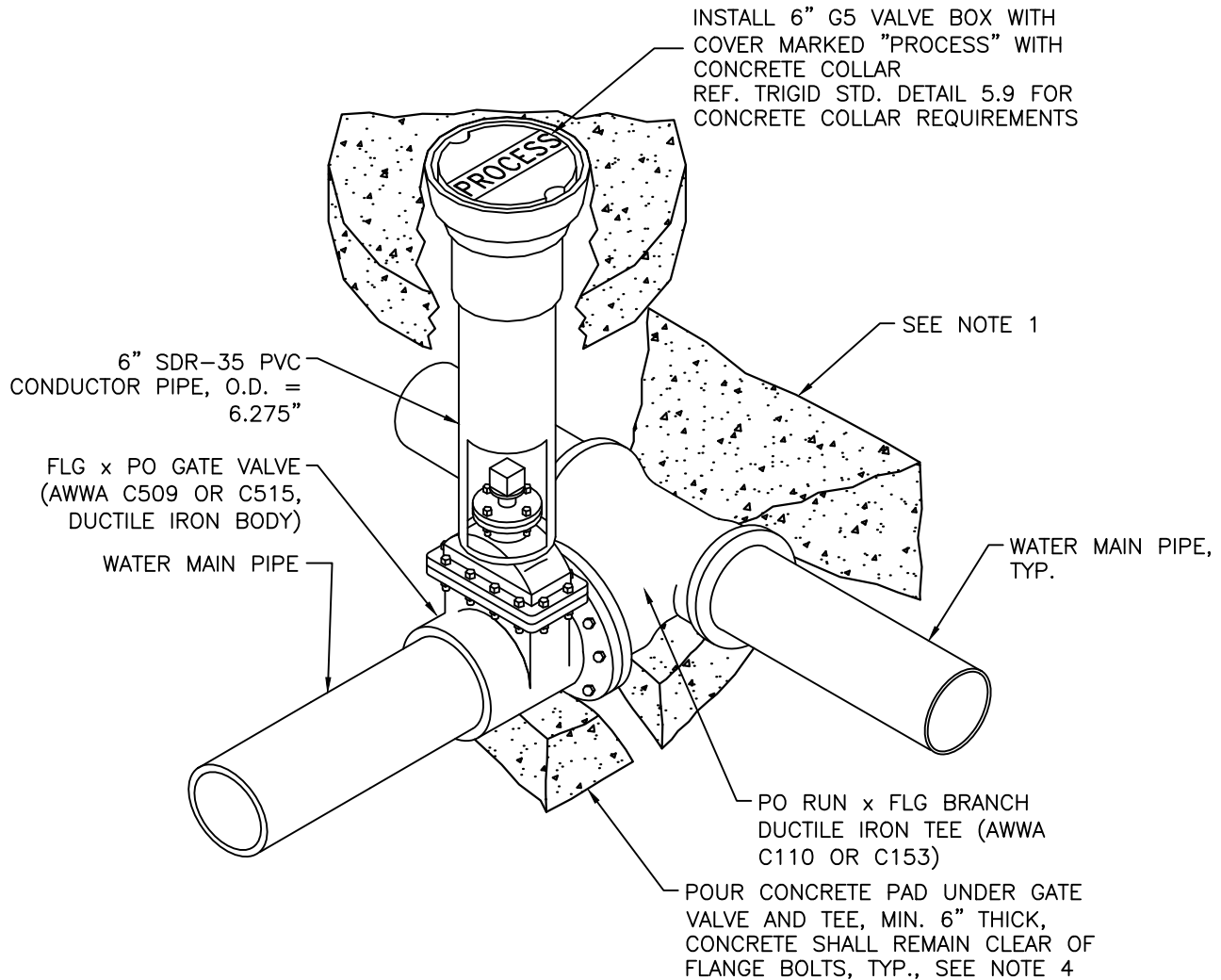

MATERIAL LIST

QTY.	DESCRIPTION
1	PO RUN x FLG BRANCH DUCTILE IRON TEE (AWWA C110 OR C153)
1	FLG x PO GATE VALVE WITH DUCTILE IRON BODY (AWWA C509 OR C515)
1	6" G5 VALVE BOX WITH COVER MARKED "PROCESS"
1	6" SDR-35 PVC CONDUCTOR PIPE SECTION, O.D. = 6.275"
-	CONCRETE BULK - THRUST BLOCKS, PADS, COLLARS

SOURCE: TMWA DETAIL 10B-5

 <p>440 USA PKWY, SUITE 105 McCARRAN, NEVADA 89437</p>	DRAWN: _____ NT CHECKED: _____ CLR REV: _____ MAY 2024 REV: _____	STANDARD DETAIL FLANGED TEES FLG x MJ GATE VALVES - RESTRAINED -	PROCESS  5.1.5



NOTES:

1. COUPLINGS SHALL BE HYMAX 2000 SERIES COUPLINGS AS MANUFACTURED BY TOTAL PIPING SOLUTIONS, INC. OR TRIGID APPROVED EQUIVALENT.
2. SNAP MACHINED END OFF TRANSITE (AC) PIPE TO EXPOSE ROUGH BARREL. INSTALL COUPLING ON ROUGH BARREL SECTION OF TRANSITE PIPE.
3. FIELD MEASURE ACTUAL PIPE O.D. PRIOR TO ORDERING COUPLING. FOR OTHER TYPES OF PIPE NOT LISTED IN THE CHARTS BELOW AND/OR PIPE O.D.'S WHICH MAY DIFFER FROM THOSE LISTED BELOW, CONSULT MANUFACTURER'S SIZING CHART.

TYPE OF PIPE	6" C900 PVC (C900) 6" DUCTILE IRON (DI)		6" TRANSITE (AC) ROUGH BARREL CLASS 100/150/200	
6" C900 PVC (C900) 6" DUCTILE IRON (DI)	Hymax COUPLING PART NO.	LOW RANGE (C900, DI) 6.42 - 7.05	Hymax COUPLING PART NO.	HIGH RANGE (AC) 7.01 - 7.68
	2000-0768-260	LOW RANGE (C900, DI) 6.42 - 7.05	2000-0768-260	LOW RANGE (C900, DI) 6.42 - 7.05
6" TRANSITE (AC) ROUGH BARREL CLASS 100/150/200	Hymax COUPLING PART NO.	LOW RANGE (C900, DI) 6.42 - 7.05	Hymax COUPLING PART NO.	HIGH RANGE (AC) 7.01 - 7.68
	2000-0768-260	HIGH RANGE (AC) 7.01 - 7.68	2000-0768-260	HIGH RANGE (AC) 7.01 - 7.68

TYPE OF PIPE	8" C900 PVC (C900) 8" DUCTILE IRON (DI)		8" TRANSITE (AC) ROUGH BARREL CLASS 100/150/200	
8" C900 PVC (C900) 8" DUCTILE IRON (DI)	Hymax COUPLING PART NO.	LOW RANGE (C900, DI) 8.54 - 9.17	Hymax COUPLING PART NO.	HIGH RANGE (AC) 9.13 - 9.84
	2000-0984-260	LOW RANGE (C900, DI) 8.54 - 9.17	2000-0984-260	LOW RANGE (C900, DI) 8.54 - 9.17
8" TRANSITE (AC) ROUGH BARREL CLASS 100/150/200	Hymax COUPLING PART NO.	LOW RANGE (C900, DI) 8.54 - 9.17	Hymax COUPLING PART NO.	HIGH RANGE (AC) 9.13 - 9.84
	2000-0984-260	HIGH RANGE (AC) 9.13 - 9.84	2000-0984-260	HIGH RANGE (AC) 9.13 - 9.84

TYPE OF PIPE	10" C900 PVC (C900) 10" DUCTILE IRON (DI)		10" TRANSITE (AC) ROUGH BARREL CLASS 100/150		10" TRANSITE (AC 200) ROUGH BARREL - CLASS 200	
10" C900 PVC (C900) 10" DUCTILE IRON (DI)	Hymax COUPLING PART NO.	LOW RANGE (C900, DI) 10.96 - 11.63	Hymax COUPLING PART NO.	LOW RANGE (AC) 10.96 - 11.63	Hymax COUPLING PART NO.	HIGH RANGE (AC 200) 11.59 - 12.26
	2000-1226-260	LOW RANGE (C900, DI) 10.96 - 11.63	2000-1226-260	LOW RANGE (C900, DI) 10.96 - 11.63	2000-1226-260	LOW RANGE (C900, DI) 10.96 - 11.63
10" TRANSITE (AC) ROUGH BARREL CLASS 100/150	Hymax COUPLING PART NO.	LOW RANGE (C900, DI) 10.96 - 11.63	Hymax COUPLING PART NO.	LOW RANGE (AC) 10.96 - 11.63	Hymax COUPLING PART NO.	HIGH RANGE (AC 200) 11.59 - 12.26
	2000-1226-260	LOW RANGE (AC) 10.96 - 11.63	2000-1226-260	LOW RANGE (AC) 10.96 - 11.63	2000-1226-260	LOW RANGE (AC) 10.96 - 11.63
10" TRANSITE (AC 200) ROUGH BARREL CLASS 200	Hymax COUPLING PART NO.	LOW RANGE (C900, DI) 10.96 - 11.63	Hymax COUPLING PART NO.	LOW RANGE (AC) 10.96 - 11.63	Hymax COUPLING PART NO.	HIGH RANGE (AC 200) 11.59 - 12.26
	2000-1226-260	HIGH RANGE (AC 200) 11.59 - 12.26	2000-1226-260	HIGH RANGE (AC 200) 11.59 - 12.26	2000-1226-260	HIGH RANGE (AC 200) 11.59 - 12.26

TYPE OF PIPE	12" C900 PVC (C900) 12" DUCTILE IRON (DI)		12" TRANSITE (AC) ROUGH BARREL CLASS 100/150/200	
12" C900 PVC (C900) 12" DUCTILE IRON (DI)	Hymax COUPLING PART NO.	LOW RANGE (C900, DI) 13.15 - 13.78	Hymax COUPLING PART NO.	HIGH RANGE (AC) 13.74 - 14.41
	2000-1441-260	LOW RANGE (C900, DI) 13.15 - 13.78	2000-1441-260	LOW RANGE (C900, DI) 13.15 - 13.78
12" TRANSITE (AC) ROUGH BARREL CLASS 100/150/200	Hymax COUPLING PART NO.	LOW RANGE (C900, DI) 13.15 - 13.78	Hymax COUPLING PART NO.	HIGH RANGE (AC) 13.74 - 14.41
	2000-1441-260	HIGH RANGE (AC) 13.74 - 14.41	2000-1441-260	HIGH RANGE (AC) 13.74 - 14.41

SOURCE: TMWA DETAIL 10C-2



DRAWN: \_\_\_\_\_ NT  
 CHECKED: \_\_\_\_\_ CLR  
 REV: \_\_\_\_\_ MAY 2024  
 REV: \_\_\_\_\_

STANDARD DETAIL

PROCESS

COUPLING

5.2.1



TAP SIZE – FLANGED BRANCH							
MAIN SIZE	VENDOR	MAIN TYPE	4"	6"	8"	10"	12"
4"	SM ROM	DI/CI PVC	663-04800400-200 SST-4.90 x 4" FL				
6"	SM ROM	DI/CI PVC	663-06630400-000 SST-7.00 x 4" FL	663*06630600-200 SST-7.00 x 6" FL			
	SM ROM	TR	663-(OD)400-000 SST-(OD) x 4" FL	663-(OD)0600-200 SST-(OD) x 6" FL			
8"	SM ROM	DI/CI PVC	663-09050400-000 SST-9.06 x 4" FL	663-09050600-000 SST-9.06 x 6" FL	663-09050800-200 SST-9.06 x 8" FL		
	SM ROM	TR	663-(OD)0400-000 SST-(OD) x 4" FL	663-(OD)0600-000 SST-(OD) x 6" FL	663-(OD)0800-200 SST-(OD) x 8" FL		
	SM ROM	SCH 40 STEEL	663-08630400-000 SST-8.63 x 4" FL	663-08630600-000 SST-8.63 x 6" FL	663-08630800-200 SST-8.63 x 8" FL		
10"	SM ROM	DI/CI PVC	663-11100400-000 SST-11.45 x 4" FL	663-11100600-000 SST-11.45 x 6" FL	663-11100800-000 SST-11.45 x 8" FL	663-11101000-200 SST-11.45 x 10" FL	
	SM ROM	TR	663-(OD)0400-000 SST-(OD) x 4" FL	663-(OD)0600-000 SST-(OD) x 6" FL	663-(OD)0800-000 SST-(OD) x 8" FL	663-(OD)1000-200 SST-(OD) x 10" FL	
	SM ROM	SCH 40 STEEL	663-10750400-000 SST-11.13 x 4" FL	663-10750600-000 SST-11.13 x 6" FL	663-10750800-000 SST-11.13 x 8" FL	663-10751000-200 SST-11.13 x 10" FL	
12"	SM ROM	DI/CI PVC	663-10750400-000 SST-13.30 x 4" FL	663-13200600-000 SST-13.30 x 6" FL	663-13200800-000 SST-13.30 x 8" FL	663-13201000-000 SST-13.30 x 10" FL	663-13201200-200 SST-13.30 x 12" FL
	SM ROM	TR	663-(OD)0400-000 SST-(OD) x 4" FL	663-(OD)0600-000 SST-(OD) x 6" FL	663-(OD)0800-000004 SST-(OD) x 8" FL	663-(OD)1000-000 SST-(OD) x 10" FL	663-(OD)1200-200 SST-(OD) x 12" FL
	SM ROM	SCH 40 STEEL	663-12750400-000 SST-12.85 x 4" FL	663-12750600-000 SST-12.85 x 6" FL	663-12750800-000 SST-12.85 x 8" FL	663-12751000-000 SST-12.85 x 10" FL	663-12751200-200 SST-12.85 x 12" FL

NOTES:

1. MAXIMUM TEST PRESSURE IS 300 PSI FOR LISTED MANUFACTURERS.
2. FLANGES (FL) SHALL BE STAINLESS STEEL ASTM A 240, TYPE 304.
3. VENDOR (MANUFACTURER): SM = SMITH-BLAIR, ROM = ROMAC INDUSTRIES
4. (OD) = PIPE OUTSIDE DIAMETER. CHECK WITH MANUFACTURER FOR CATALOG NUMBER FOR OTHER SIZES.
5. FOR TAPS ON TRANSITE MAINS OD MUST BE FIELD MEASURED PRIOR TO ORDERING PARTS.

SOURCE: TMWA DETAIL 10D-2

 <p>440 USA PKWY, SUITE 105 McCARRAN, NEVADA 89437</p>	DRAWN: _____ NT CHECKED: _____ CLR REV: _____ MAY 2024 REV: _____	STANDARD DETAIL  <h2 style="text-align: center;">PROCESS WATER TAPPING SLEEVES</h2>	PROCESS  <h2 style="text-align: center;">5.3.1</h2>

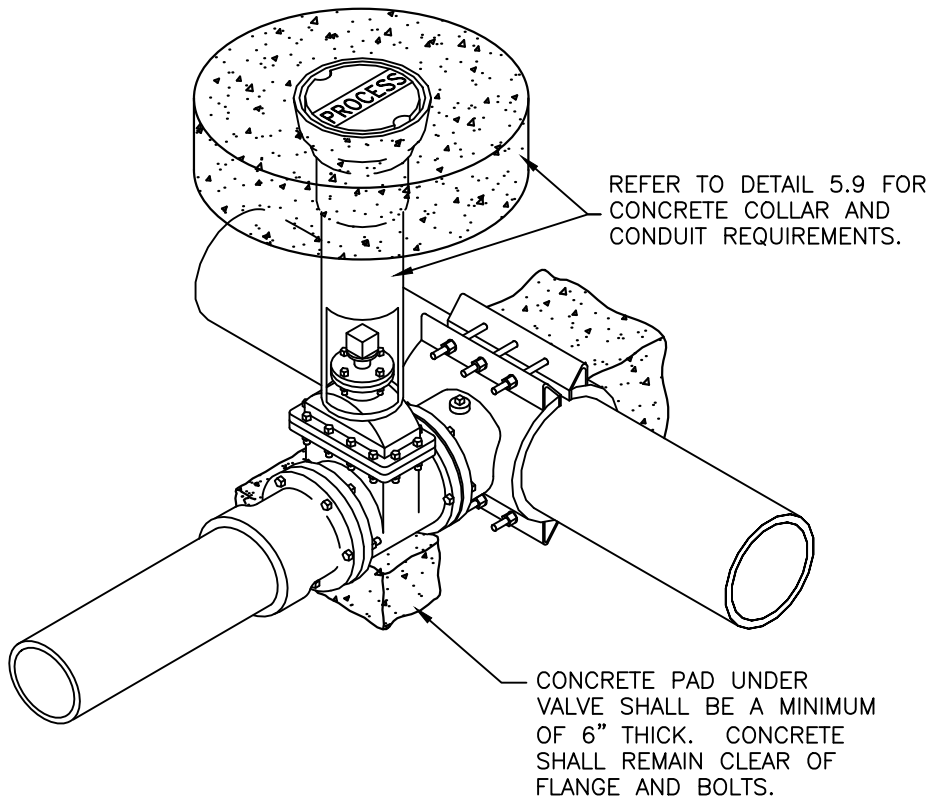

NOTES:

1. REQUIRES ONE (1) TAPPING SLEEVE. REFER TO 5.3.1.
2. WHEN TAPPING STEEL OR OD STEEL BACKING PLATE MUST BE DESIGNED BY ENGINEER. WHEN TAPPING OD STEEL SIZE ON SIZE, REDUCE TAP ONE SIZE THEN BELL UP AFTER TAP.
3. REFER TO DETAIL 5.13 FOR THRUST BLOCK SIZING. BAG CONCRETE IS NOT ACCEPTABLE FOR PAD OR THRUST BLOCK. CONCRETE SHALL HAVE A MINIMUM 28 DAY COMPRESSIVE STRENGTH OF 3,000 PSI.
4. ALL EXPOSED METAL MUST BE COATED WITH BRUSH ON MASTIC.
5. REMOVE TEST PLUG AND HYDROSTATICALLY PRESSURE TEST TAPPING SLEEVE NOT TO EXCEED MANUFACTURER'S PRESSURE RATING, APPLY PIPE COMPOUND, AND REINSERT PLUG.
6. VALVE SHALL BE BLIND FLANGED AND PRESSURE TESTED AT TIME OF TAPPING SLEEVE PRESSURE TEST.
7. TAP SHALL BE A MINIMUM OF 24" FROM THE CUT OR SPIGOT END OF THE PIPE OR THE PIPE TO BELL TRANSITION.

MATERIAL LIST

QTY	DESCRIPTION
1	FL x FL RESILIENT WEDGE GATE VALVE WITH 2" OPERATING NUT (SIZE TO MATCH TAP DIAMETER)
1	TAPPING SLEEVE (STAINLESS STEEL FLANGE)
1	FL x PO ADAPTER
1	6" $\phi$ SDR-35 PVC CONDUIT PIPE SECTION
1	6" $\phi$ G5 VALVE BOX WITH COVER MARKED "PROCESS"
1	FULL FACE GASKET
1	CONCRETE BULK
1	MASTIC (1 GALLON CAN - BRUSH ON)

SOURCE: TMWA DETAIL 10D-3



DRAWN: \_\_\_\_\_ NT  
 CHECKED: \_\_\_\_\_ CLR  
 REV: \_\_\_\_\_ MAY 2024  
 REV: \_\_\_\_\_

STANDARD DETAIL

PROCESS

STANDARD TAP 4"-12"

5.3.2

NOTES:

1. REQUIRES ONE (1) TAPPING SLEEVE. REFER TO 2.3.1.
2. WHEN TAPPING STEEL OR OD STEEL BACKING PLATE MUST BE DESIGNED BY ENGINEER. WHEN TAPPING OD STEEL SIZE ON SIZE, REDUCE TAP ONE SIZE THEN BELL UP AFTER TAP.
3. REFER TO DETAIL 2.14 FOR THRUST BLOCK SIZING AND CONCRETE REQUIREMENTS. BAG CONCRETE IS NOT ACCEPTABLE FOR PAD OR THRUST BLOCK. USE THRUST BLOCK SIZING FOR DEAD END CONDITION FOR 90 DEGREE ELBOWS.
4. ALL EXPOSED METAL MUST BE COATED WITH BRUSH ON MASTIC.
5. REMOVE TEST PLUG AND HYDROSTATICALLY PRESSURE TEST TAPPING SLEEVE NOT TO EXCEED MANUFACTURER'S PRESSURE RATING, APPLY PIPE COMPOUND, AND REINSERT PLUG.
6. VALVE SHALL BE BLIND FLANGED AND PRESSURE TESTED AT TIME OF TAPPING SLEEVE PRESSURE TEST.
7. TAP SHALL BE A MINIMUM OF 24" FROM THE CUTOR SPIGOT END OF THE PIPE OR THE PIPE TO BELL TRANSITION.

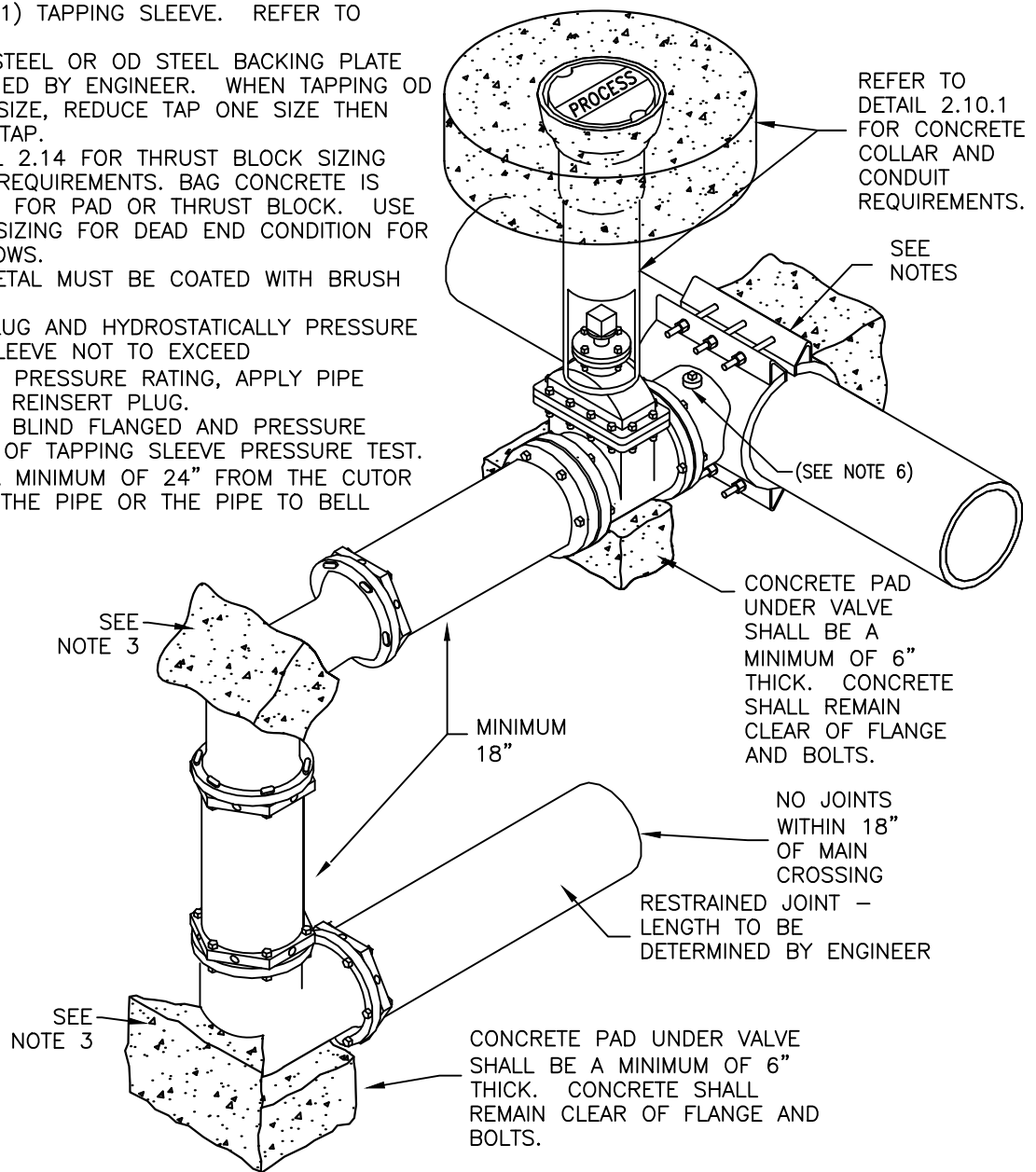

MATERIAL LIST

QTY	DESCRIPTION
1	TAPPING SLEEVE (STAINLESS STEEL FLANGE)
1	FL x FL RESILIENT WEDGE GATE VALVE WITH 2" OPERATING NUT (SIZE TO MATCH TAP DIAMETER)
1	6" $\phi$ SDR-35 PVC CONDUIT PIPE
1	G5 VALVE BOX WITH COVER MARKED "WATER"
1	FL x MJ ADAPTER - RESTRAINED
1	CONCRETE BULK
1	MASTIC (1 GALLON CAN - BRUSH ON)
2	90° MJ x MJ ELBOW, DUCTILE IRON - RESTRAINED
1	CONCRETE BULK
2	PE x PE DUCTILE IRON PIPE MINIMUM 18"

SOURCE: TMWA DETAIL 10D-4

 440 USA PKWY, SUITE 105 McCARRAN, NEVADA 89437	DRAWN: _____ NT CHECKED: _____ CLR REV: _____ MAY 2024 REV: _____	STANDARD DETAIL  <b>REVERSE TAP 4"-12"</b>	PROCESS  <b>5.3.3</b>

PLAN VIEW

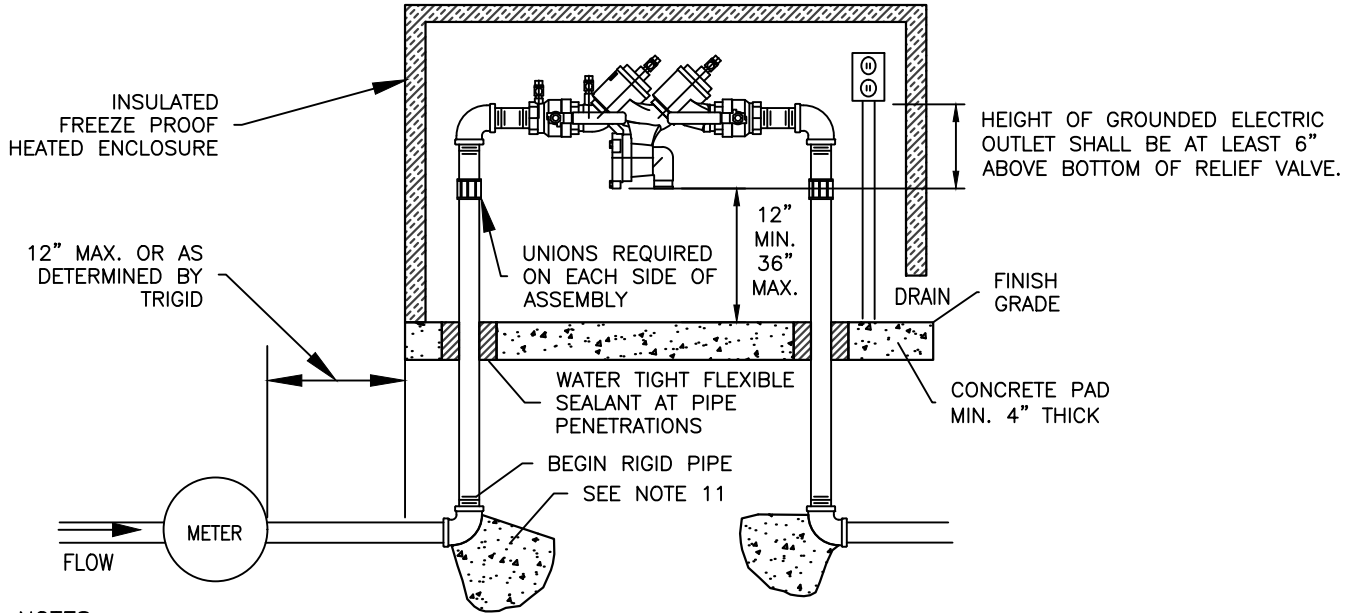
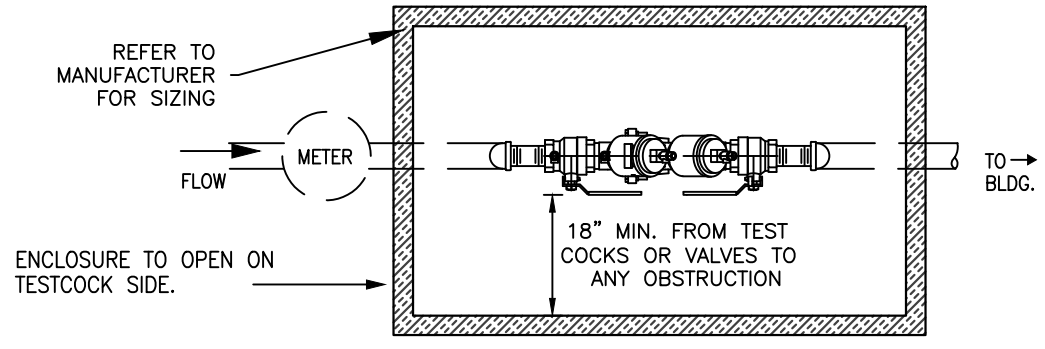

NOTES:

1. ASSEMBLY SHALL BE A USC APPROVED LEAD FREE DEVICE.
2. THE RP SHALL BE INSTALLED ABOVE GRADE.
3. GROUNDED ELECTRIC SUPPLY SHALL BE A MINIMUM OF 6" ABOVE BOTTOM OF RELIEF VALVE AND STUBBED TO THE OUTSIDE.
4. NO STOP AND WASTE VALVES.
5. FREEZE PROOF INSULATED BOX AND 1 SOURCE OF HEAT ARE REQUIRED. 2 SOURCES OF HEAT ARE STRONGLY RECOMMENDED.
6. INSULATED BOX SHALL SWING CLEAR OF ASSEMBLY TO PROVIDE CLEARANCES SHOWN OR INSULATED BOX SHALL BE SIZED TO PROVIDE CLEARANCES SHOWN.
7. SPRING LOADED LID REQUIRED ON LARGE BOXES.
8. THERMAL EXPANSION PROTECTION IS REQUIRED IN ANY DOMESTIC WATER SUPPLY SYSTEM THAT IS DOWNSTREAM FROM A BACKFLOW PREVENTION DEVICE. REFERENCE: UNIFORM PLUMBING CODE & NAC 445A.67235.
9. INSPECTION BY TRIGID PERSONNEL REQUIRED BEFORE METER IS SET OR SERVICE IS ACTIVATED.
10. IF INITIAL TEST DONE BY TRIGID PERSONNEL FAILS, RETESTING OF BACKFLOW ASSEMBLY IS REQUIRED WITHIN 7 DAYS AFTER METER IS SET OR SERVICE ACTIVATION. COPY OF TEST RESULTS TO BE FORWARDED TO TRIGID PERSONNEL BY A CERTIFIED ASSEMBLY TESTER WITHIN THAT SAME TIMEFRAME.
11. MINIMUM DIMENSIONS FOR THE THRUST BLOCK BEARING AREA FOR PIPE 2" AND SMALLER SHALL BE 8" X 8" AND 12" IN DEPTH. ALL OTHER SIZES TO BE DETERMINED BY TRIGID ENGINEER.

SOURCE: TMWA DETAIL 10A-2



DRAWN: \_\_\_\_\_ NT  
 CHECKED: \_\_\_\_\_ CLR  
 REV: \_\_\_\_\_ MAY 2024  
 REV: \_\_\_\_\_

STANDARD DETAIL

PROCESS

REDUCED PRESSURE PRINCIPLE  
 ASSEMBLY FOR DOMESTIC USE  
 EXTERNAL - HORIZONTAL

5.4.1

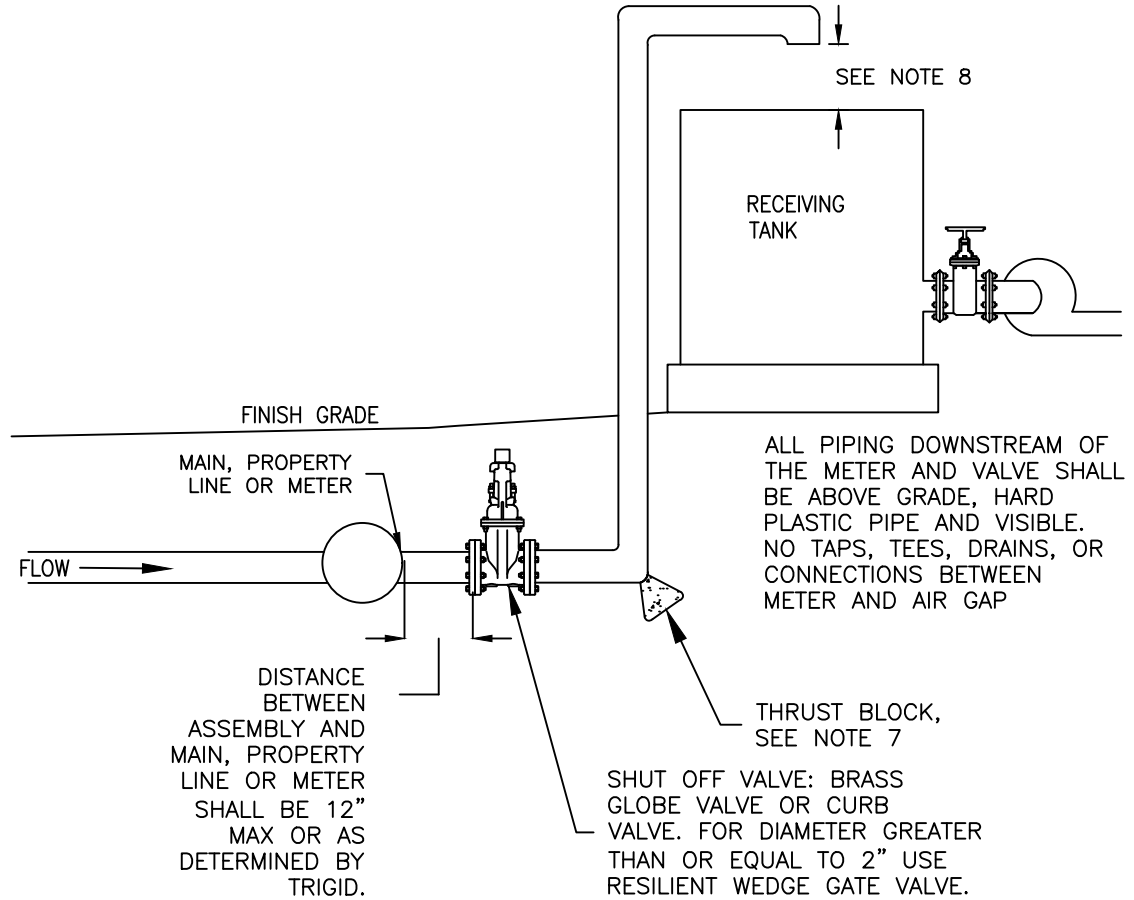

NOTES:

1. IF THE AIR GAP IS INSTALLED IN AN AREA WHERE CORROSIVE FUMES OR GASES COULD RENDER THE ASSEMBLY INEFFECTIVE, AN RP MAY BE REQUIRED UPSTREAM ON THE SERVICE LINE.
2. NO STOP AND WASTE VALVES.
3. THE AIR GAP SHALL BE READILY ACCESSIBLE FOR INSPECTION.
4. THE AIR GAP SHALL REMAIN OPERATIVE AND EFFECTIVE THROUGHOUT THE YEAR WITHOUT BEING BYPASSED. TRIGID SHALL BE NOTIFIED OF ANY BYPASS INSTALLED.
5. CALL LOCAL BUILDING AND/OR FIRE DEPARTMENTS FOR DEPTH AND TYPE OF PIPE TO BE USED.
6. INSPECTION BY TRIGID PERSONNEL REQUIRED BEFORE METER IS SET OR SERVICE IS ACTIVATED.
7. THRUST BLOCKS REQUIRED ON ALL BELOW GRADE ELBOWS. SIZE TO BE VERIFIED BY TRIGID ENGINEER.
8. AIR GAP MUST BE AT LEAST TWICE THE EFFECTIVE DIAMETER OF THE PIPE OR IF THE PIPE IS AFFECTED BY SIDE WALLS, AT LEAST THREE TIMES THE EFFECTIVE DIAMETER OF THE PIPE. IN NO CASE SHALL THE AIR GAP BE LESS THAN 1".

SOURCE: TMWA DETAIL 10A-13



DRAWN: \_\_\_\_\_ NT  
 CHECKED: \_\_\_\_\_ CLR  
 REV: \_\_\_\_\_ MAY 2024  
 REV: \_\_\_\_\_

STANDARD DETAIL

PROCESS

AIR GAP SEPARATION

5.4.2

NOTES:

1. REFERENCE TRIGID STANDARD DETAIL 5.13 FOR THRUST BLOCK SIZING AND REQUIREMENTS (DEAD END CONDITION).
2. ALL EXPOSED METAL SHALL BE COATED WITH BRUSHED-ON MASTIC.
3. ALL BOLTS AND ASSOCIATED HARDWARE SHALL BE FLUOROPOLYMER COATED.
4. TEE, VALVE, FITTINGS, DUCTILE IRON PIPE, AND OTHER METAL PARTS SHALL BE ENCASED WITH POLYETHYLENE WRAP PER AWWA C105.
5. CONCRETE FOR PADS SHALL HAVE A COMPRESSIVE STRENGTH OF NOT LESS THAN 3,000 PSI AFTER 28 DAYS. BAG CONCRETE MIX IS NOT ACCEPTABLE.

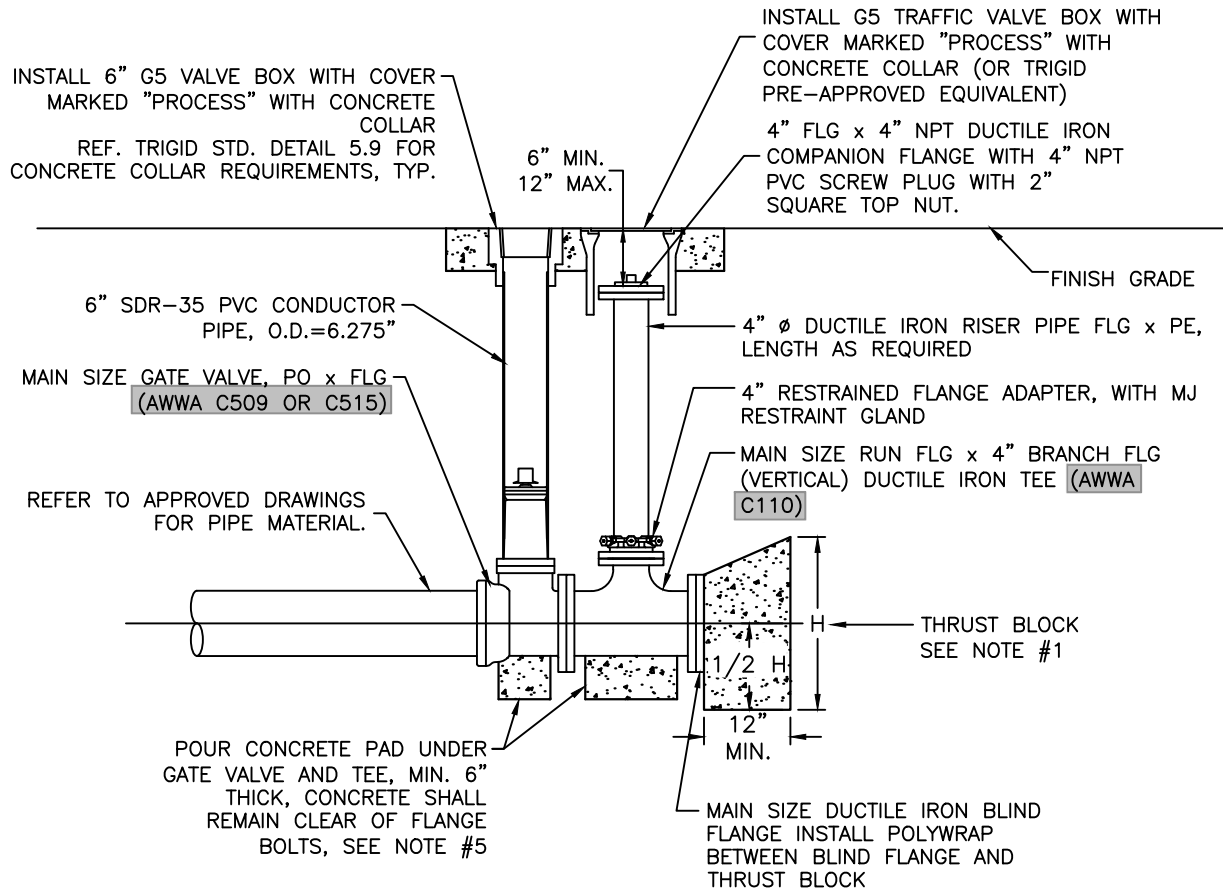

MATERIAL LIST

QTY.	DESCRIPTION
1	MAIN SIZE RUN FLG x 4" BRANCH FLG DUCTILE IRON TEE (AWWA C110)
1	MAIN SIZE GATE VALVE, PO x FLG, (AWWA C509 OR C515)
1	MAIN SIZE DUCTILE IRON BLIND FLANGE
1	4" FLG x 4" NPT DUCTILE IRON COMPANION FLANGE
1	4" Ø DUCTILE IRON RISER PIPE FLG x PE (LENGTH AS REQUIRED)
1	4" RESTRAINED FLANGED ADAPTER WITH MJ RESTRAINT GLAND
1	4" PVC SCREW PLUG, NPT, WITH 2" SQUARE TOP NUT
2	G5 TRAFFIC VALVE BOX WITH COVER MARKED "PROCESS"
1	6" SDR-35 PVC CONDUIT PIPE SECTION, O.D.=6.275"
-	CONCRETE BULK - THRUST BLOCKS, PADS, COLLARS

SOURCE: TMWA DETAIL 10E-2



DRAWN: \_\_\_\_\_ NT  
 CHECKED: \_\_\_\_\_ CLR  
 REV: \_\_\_\_\_ MAY 2024  
 REV: \_\_\_\_\_

STANDARD DETAIL

**PERMANENT DEAD-END  
 LOCATION FLUSH ASSEMBLY**

PROCESS

**5.5.1**

NOTES:

1. ALL EXPOSED METAL SHALL BE COATED WITH BRUSHED-ON MASTIC.
2. ALL BOLTS AND ASSOCIATED HARDWARE SHALL BE FLUOROPOLYMER COATED.
3. TEE, VALVE, FITTINGS, DUCTILE IRON PIPE, AND OTHER METAL PARTS SHALL BE ENCASED WITH POLYETHYLENE WRAP PER AWWA C105.
4. CONCRETE FOR PADS SHALL HAVE A COMPRESSIVE STRENGTH OF NOT LESS THAN 3,000 PSI AFTER 28 DAYS. BAG CONCRETE MIX IS NOT ACCEPTABLE.

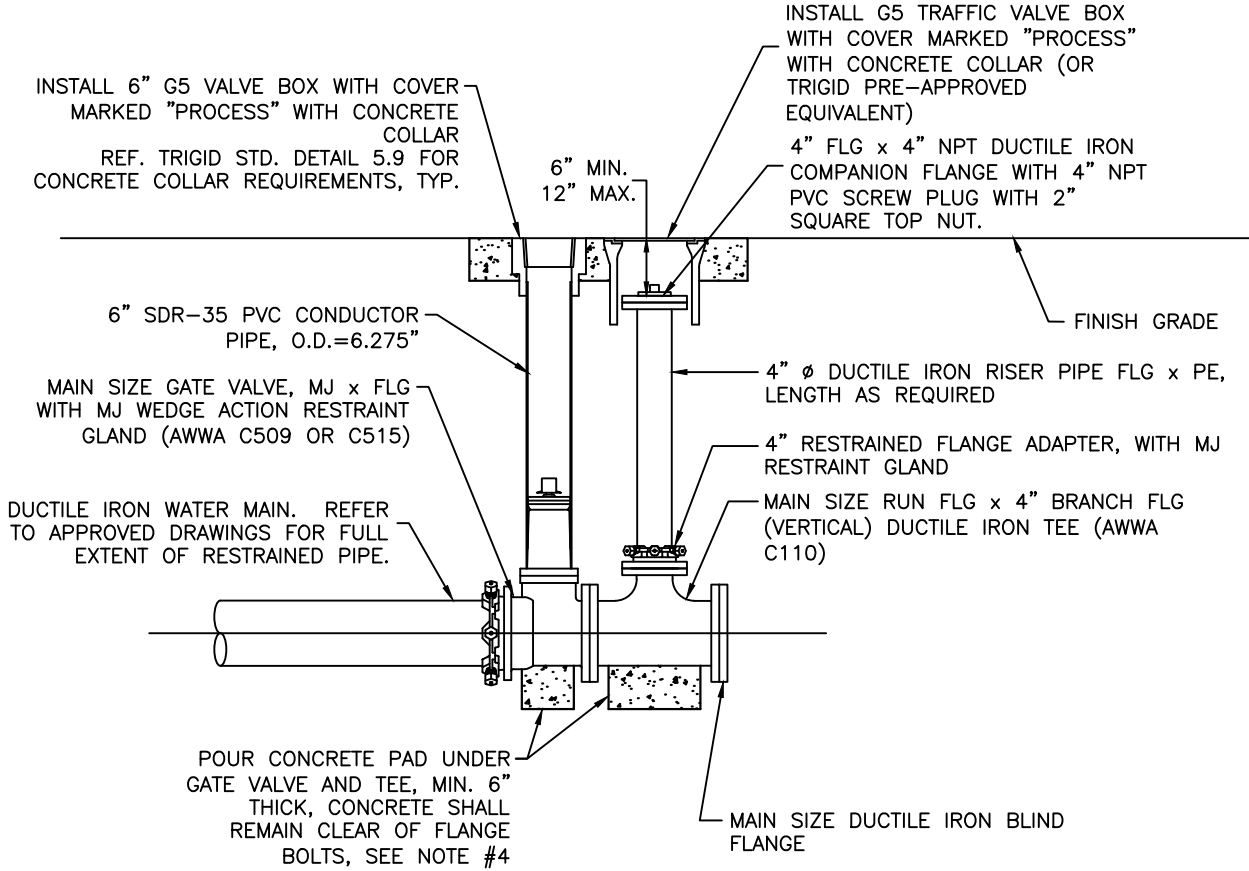

MATERIAL LIST

QTY.	DESCRIPTION
1	MAIN SIZE RUN FLG x 4" BRANCH FLG DUCTILE IRON TEE (AWWA C110)
1	MAIN SIZE GATE VALVE, MJ x FLG, (AWWA C509 OR C515)
1	MAIN SIZE MJ WEDGE ACTION RESTRAINT GLAND
1	MAIN SIZE DUCTILE IRON BLIND FLANGE
1	4" FLG x 4" NPT DUCTILE IRON COMPANION FLANGE
1	4" Ø DUCTILE IRON RISER PIPE FLG x PE (LENGTH AS REQUIRED)
1	4" RESTRAINED FLANGE ADAPTER, WITH MJ RESTRAINT GLAND
1	4" PVC SCREW PLUG, NPT, WITH 2" SQUARE TOP NUT
2	G5 TRAFFIC VALVE BOX WITH COVER MARKED "PROCESS"
1	6" SDR-35 PVC CONDUIT PIPE SECTION, O.D.=6.275"
-	CONCRETE BULK - PADS, COLLARS

SOURCE: TMWA DETAIL 10E-3



DRAWN: \_\_\_\_\_ NT  
 CHECKED: \_\_\_\_\_ CLR  
 REV: \_\_\_\_\_ MAY 2024  
 REV: \_\_\_\_\_

STANDARD DETAIL

PROCESS

TEMPORARY DEAD-END  
 FLUSH ASSEMBLY

5.5.2



NOTES:

1. ALL EXPOSED METAL SHALL BE COATED WITH BRUSHED-ON MASTIC.
2. ALL BOLTS AND ASSOCIATED HARDWARE SHALL BE FLUOROPOLYMER COATED.
3. TEE, VALVES, FITTINGS, DUCTILE IRON PIPE, AND OTHER METAL PARTS SHALL BE ENCASED WITH POLYETHYLENE WRAP PER AWWA C105.
4. CONCRETE FOR PADS SHALL HAVE A COMPRESSIVE STRENGTH OF NOT LESS THAN 3,000 PSI AFTER 28 DAYS. BAG CONCRETE MIX IS NOT ACCEPTABLE.
5. MJ x FLG GATE VALVES WITH MJ WEDGE ACTION RESTRAINT GLANDS MAY BE REQUIRED IN LIEU OF PO x FLG GATE VALVES, REFERENCE WATER IMPROVEMENT PLANS.

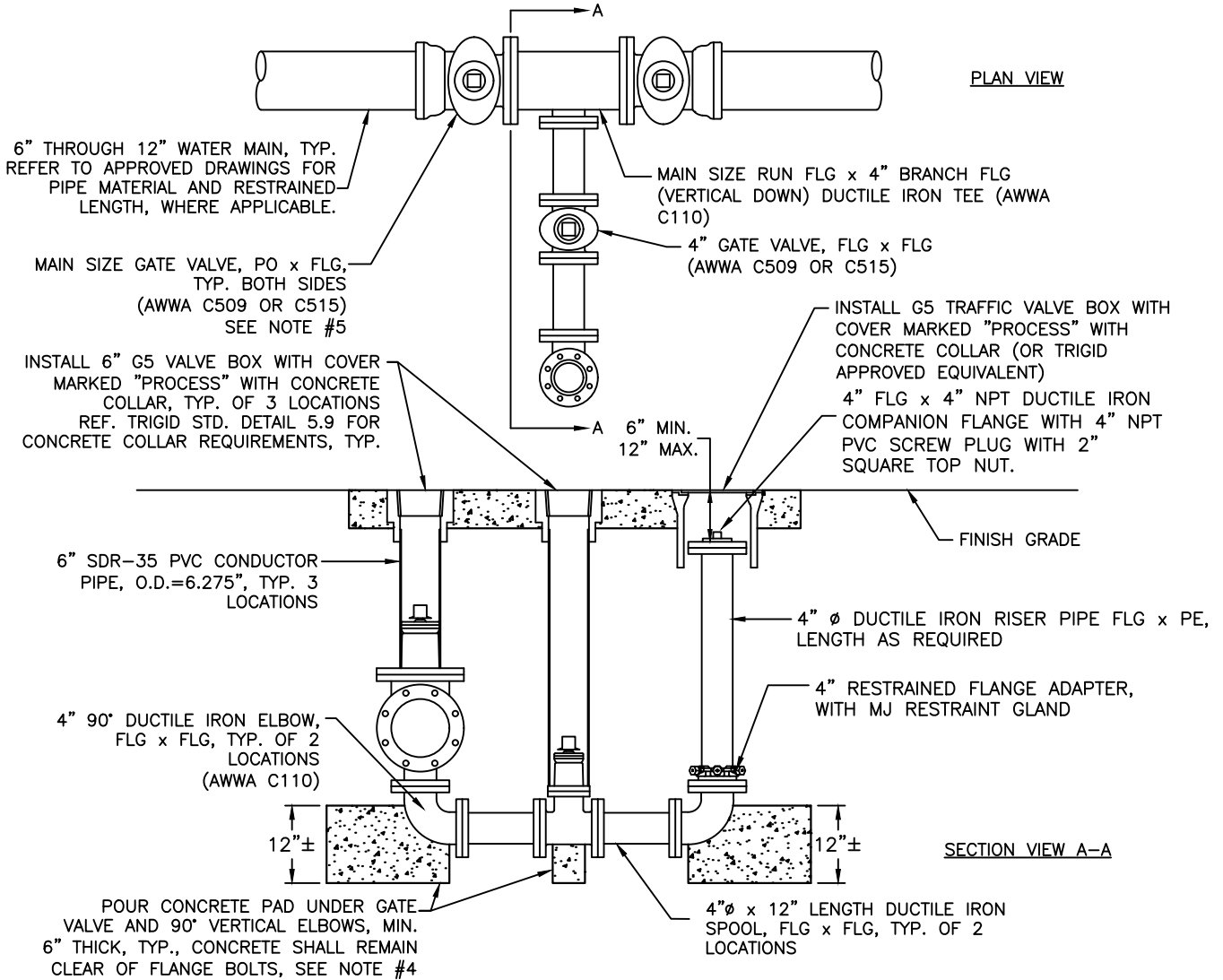

QTY.	DESCRIPTION	MATERIAL LIST
1	MAIN SIZE RUN FLG x 4" BRANCH FLG DUCTILE IRON TEE (AWWA C110)	
2	MAIN SIZE GATE VALVE, PO x FLG, (AWWA C509 OR C515)	
1	4" GATE VALVE, FLG x FLG, (AWWA C509 OR C515)	
2	4" 90° DUCTILE IRON ELBOW, FLG x FLG (AWWA C110)	
2	4" x 12" LENGTH DUCTILE IRON SPOOL, FLG x FLG	
1	4" FLG x 4" NPT DUCTILE IRON COMPANION FLANGE	
1	4" RESTRAINED FLANGE ADAPTER, WITH MJ RESTRAINT GLAND	

QTY.	DESCRIPTION	MATERIAL LIST (CONT.)
1	4" x 12" LENGTH DUCTILE IRON SPOOL, FLG x PE (LENGTH AS REQUIRED)	
1	4" PVC SCREW PLUG, NPT, WITH 2" SQUARE TOP NUT	
4	G5 TRAFFIC VALVE BOX WITH COVER MARKED "PROCESS"	
3	6" SDR-35 PVC CONDUIT PIPE SECTION, O.D.=6.275"	
-	CONCRETE BULK - THRUST BLOCKS, PADS, COLLARS	

SOURCE: TMWA DETAIL 10E-4



DRAWN: \_\_\_\_\_ NT  
 CHECKED: \_\_\_\_\_ CLR  
 REV: \_\_\_\_\_ MAY 2024  
 REV: \_\_\_\_\_

STANDARD DETAIL

# BLOW-OFF ASSEMBLY

PROCESS

## 5.5.3

NOTES:

1. ALL EXPOSED METAL SHALL BE COATED WITH BRUSHED-ON MASTIC.
2. ALL BOLTS AND ASSOCIATED HARDWARE SHALL BE FLUOROPOLYMER COATED.
3. TEE, VALVES, FITTINGS, DUCTILE IRON PIPE, AND OTHER METAL PARTS SHALL BE ENCASED WITH POLYETHYLENE WRAP PER AWWA C105.
4. CONCRETE FOR PADS SHALL HAVE A COMPRESSIVE STRENGTH OF NOT LESS THAN 3,000 PSI AFTER 28 DAYS. BAG CONCRETE MIX IS NOT ACCEPTABLE.
5. MJ x FLG GATE VALVES WITH MJ WEDGE ACTION RESTRAINT GLANDS MAY BE REQUIRED IN LIEU OF PO x FLG GATE VALVES, REFERENCE WATER IMPROVEMENT PLANS.

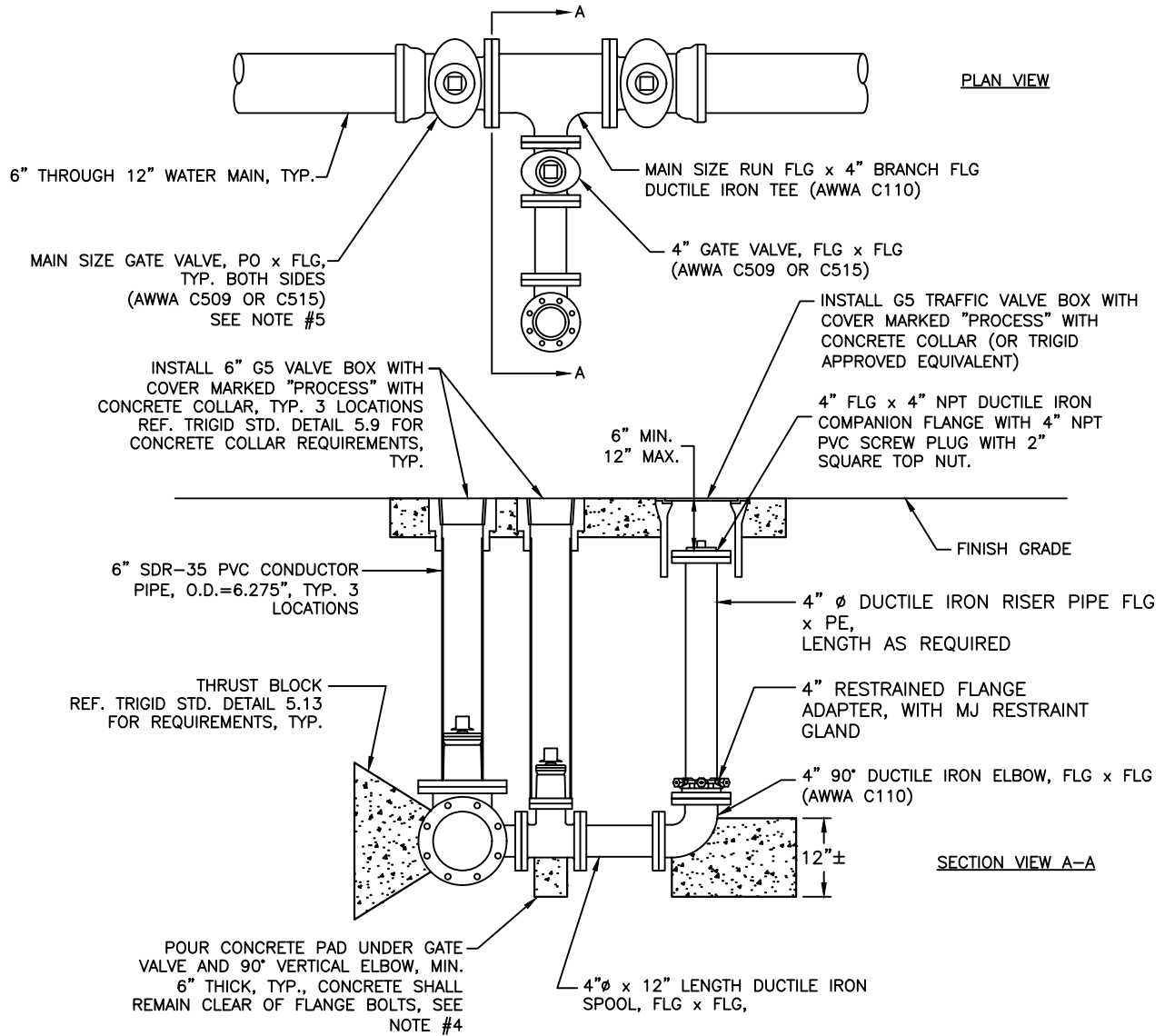

MATERIAL LIST	
QTY.	DESCRIPTION
1	MAIN SIZE RUN FLG x 4" BRANCH FLG DUCTILE IRON TEE (AWWA C110)
2	MAIN SIZE GATE VALVE, PO x FLG, (AWWA C509 OR C515)
1	4" GATE VALVE, FLG x FLG, (AWWA C509 OR C515)
1	4" 90° DUCTILE IRON ELBOW, FLG x FLG (AWWA C110)
1	4"ø x 12" LENGTH DUCTILE IRON SPOOL, FLG x FLG
1	4" FLG x 4" NPT DUCTILE IRON COMPANION FLANGE
1	4" RESTRAINED FLANGE ADAPTER WITH MJ RESTRAINT GLAND

MATERIAL LIST (CONT.)	
QTY.	DESCRIPTION
1	4"ø DUCTILE IRON SPOOL, FLG x PE (LENGTH AS REQUIRED)
1	4" PVC SCREW PLUG, NPT, WITH 2" SQUARE TOP NUT
4	G5 TRAFFIC VALVE BOX WITH COVER MARKED "PROCESS"
3	6" SDR-35 PVC CONDUIT PIPE SECTION, O.D.=6.275"
-	CONCRETE BULK - THRUST BLOCKS, PADS, COLLARS

SOURCE: TMWA DETAIL 10E-5



DRAWN: \_\_\_\_\_ NT  
 CHECKED: \_\_\_\_\_ CLR  
 REV: \_\_\_\_\_ MAY 2024  
 REV: \_\_\_\_\_

STANDARD DETAIL

# IN-LINE FLUSH ASSEMBLY

PROCESS

# 5.5.4

NOTES:

1. REFERENCE TRIGID STANDARD DETAIL 5.13 FOR THRUST BLOCK SIZING AND REQUIREMENTS (DEAD END CONDITION) FOR PERMANENT FLUSH VALVE ASSEMBLIES.
2. ALL EXPOSED METAL SHALL BE COATED WITH BRUSHED-ON MASTIC.
3. ALL BOLTS AND ASSOCIATED HARDWARE SHALL BE FLUOROPOLYMER COATED.
4. TEE, VALVE, FITTINGS, DUCTILE IRON PIPE, AND OTHER METAL PARTS SHALL BE ENCASED WITH POLYETHYLENE WRAP PER AWWA C105.
5. CONCRETE FOR PADS SHALL HAVE A COMPRESSIVE STRENGTH OF NOT LESS THAN 3,000 PSI AFTER 28 DAYS. BAG CONCRETE MIX IS NOT ACCEPTABLE.
6. RETIREMENT REQUIRES REMOVAL OF 4" DUCTILE IRON RISER WITH TAP AND ALL ASSOCIATED 2" CTS HDPE TUBING AND METER BOX. REPLACE WITH NEW 4" DUCTILE IRON FLG x PE SPOOL.

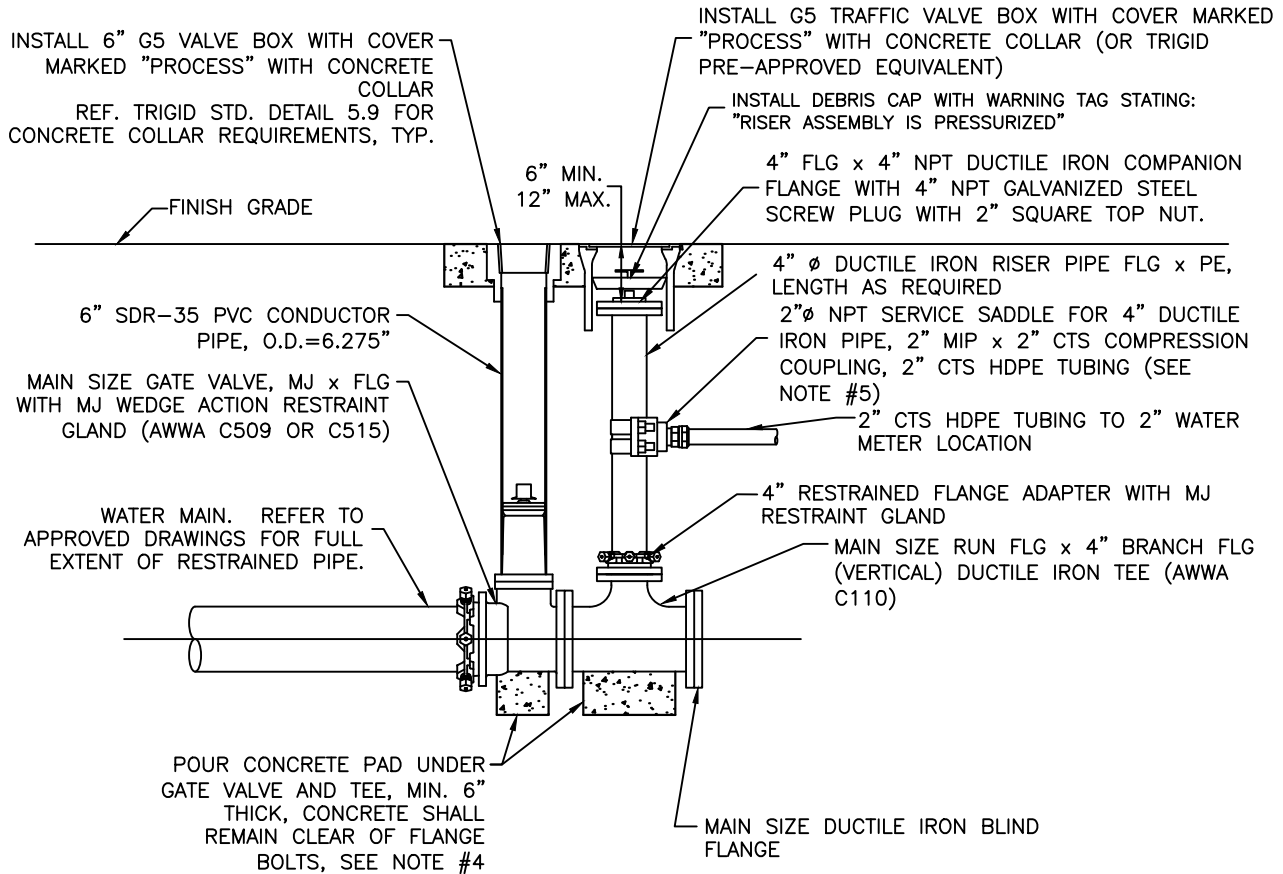

FOR EXISTING FLUSH VALVE ASSEMBLIES:

- ENSURE THAT PLUG IS PRESSURE RATED. PVC SCREW PLUGS SHALL BE REPLACED TO CONFORM TO THIS DETAIL.
- NOT ALL EXISTING FLUSH VALVE ASSEMBLIES WILL BE CONNECTED TO MECHANICALLY RESTRAINED PIPE; THRUST BLOCKS AT THE END OF THE MAIN SHALL NOT BE DISTURBED.
- RISER SHALL BE REPLACED TO THE ABOVE SPECIFICATIONS.

SOURCE: TMWA DETAIL 10E-6



DRAWN: \_\_\_\_\_ NT  
 CHECKED: \_\_\_\_\_ CLR  
 REV: \_\_\_\_\_ MAY 2024  
 REV: \_\_\_\_\_

STANDARD DETAIL

FLUSH ASSEMBLY FOR  
 CONSTRUCTION WATER SERVICE

PROCESS

5.5.5

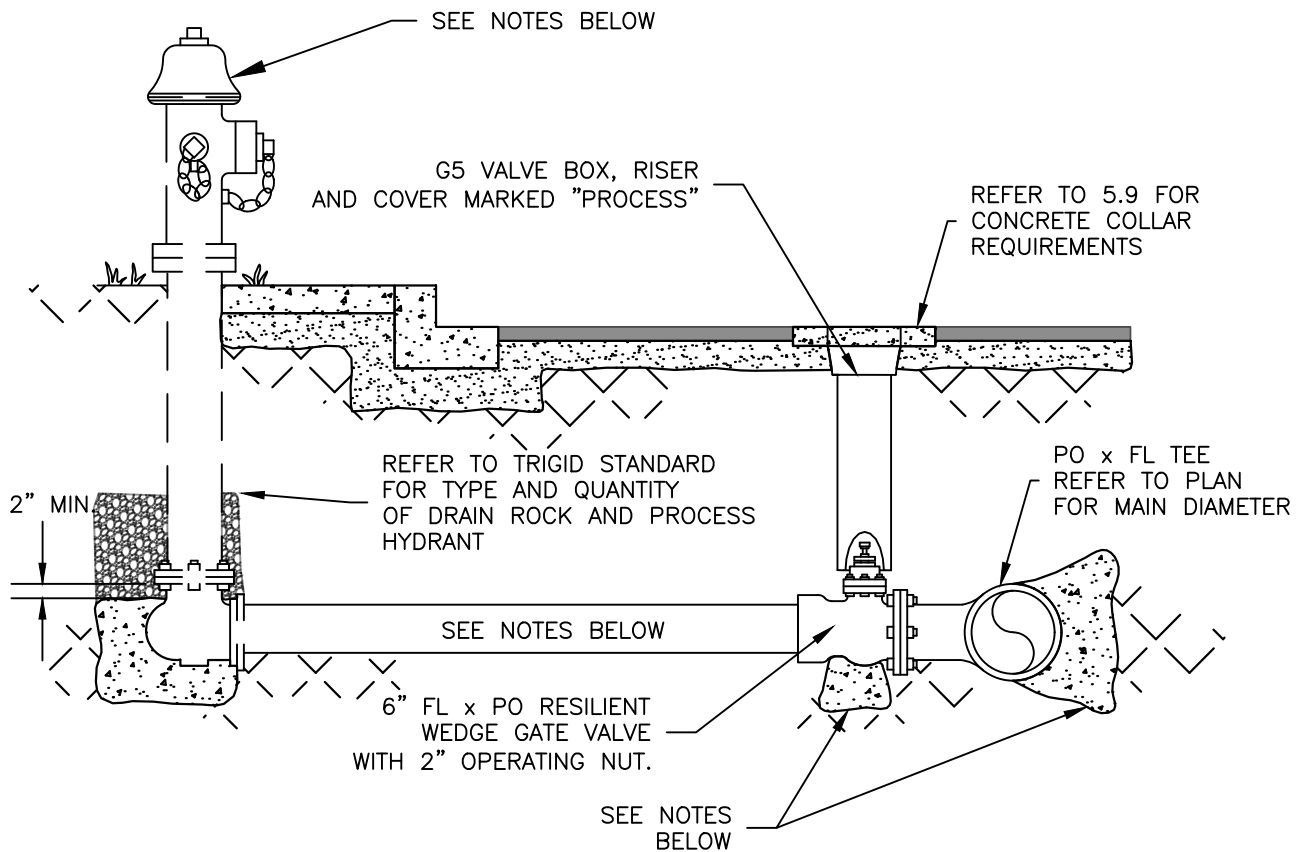

NOTES:

1. REFERENCE NAC 445A, TRIGID CONSTRUCTION AND DESIGN STANDARDS FOR REQUIRED PIPE MATERIALS. POLYETHYLENE WRAP TO BE USED ON ALL DUCTILE IRON PIPE AND FITTINGS PER AWWA C105.
2. REFER TO PLAN FOR ACTUAL DIAMETER AND LENGTH FOR HYDRANT LATERAL.
3. KEEP A MINIMUM OF 2" CLEARANCE BETWEEN FLANGES/BOLTS AND CONCRETE.
4. LOCATION OF PROCESS HYDRANT TO BE DETERMINED BY TRIGID. PROCESS HYDRANT AND BARREL EXTENSION TO BE SUPPLIED BY OTHERS.
5. REFER TO TRIGID'S ADOPTED FIRE CODE FOR HYDRANT TYPE AND CONNECTION TYPES. THE COLOR OF THE HYDRANT SHALL BE PURPLE
6. ALL EXPOSED METAL MUST BE COATED AND WRAPPED.
7. REFER TO TRIGID STANDARDS OR DETAILS 5.12-5.19 FOR THRUST BLOCK REQUIREMENTS. USE THE MOST CONSERVATIVE.

SOURCE: TMWA DETAIL 10F-2



DRAWN: \_\_\_\_\_ NT  
 CHECKED: \_\_\_\_\_ CLR  
 REV: \_\_\_\_\_ MAY 2024  
 REV: \_\_\_\_\_

STANDARD DETAIL

PROCESS

6" PROCESS HYDRANT  
 SERVICE OFF NEW MAINS

5.6.1

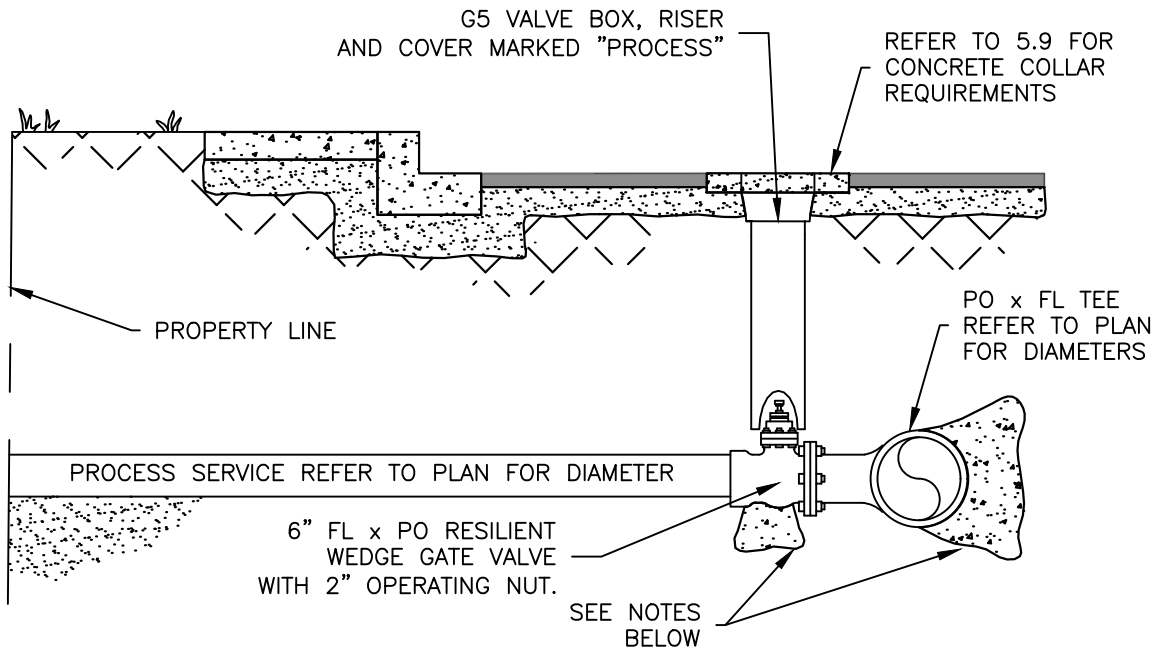

NOTES:

1. REFERENCE NAC 445A, TRIGID CONSTRUCTION AND DESIGN STANDARDS FOR REQUIRED PIPE MATERIALS. POLYETHYLENE WRAP TO BE USED ON ALL DUCTILE IRON PIPE AND FITTINGS PER AWWA C105.
2. REFER TO PLAN FOR ACTUAL DIAMETER AND LENGTH FOR PROCESS SERVICE LATERAL.
3. KEEP A MINIMUM OF 2" CLEARANCE BETWEEN FLANGES/BOLTS AND CONCRETE.
4. ALL EXPOSED METAL MUST BE COATED AND WRAPPED.
5. REFER TO TRIGID STANDARDS OR DETAILS 5.13-5.19 FOR THRUST BLOCK REQUIREMENTS. USE THE MOST CONSERVATIVE.
6. REFER TO APPROVED PLAN AND DETAILS 5.4.1-5.4.2 FOR APPROPRIATE BACKFLOW DEVICE.

SOURCE: TMWA DETAIL 10F-3



DRAWN: \_\_\_\_\_ NT  
 CHECKED: \_\_\_\_\_ CLR  
 REV: \_\_\_\_\_ MAY 2024  
 REV: \_\_\_\_\_

STANDARD DETAIL

PROCESS

PROCESS SERVICE OFF  
 NEW MAINS

5.6.2

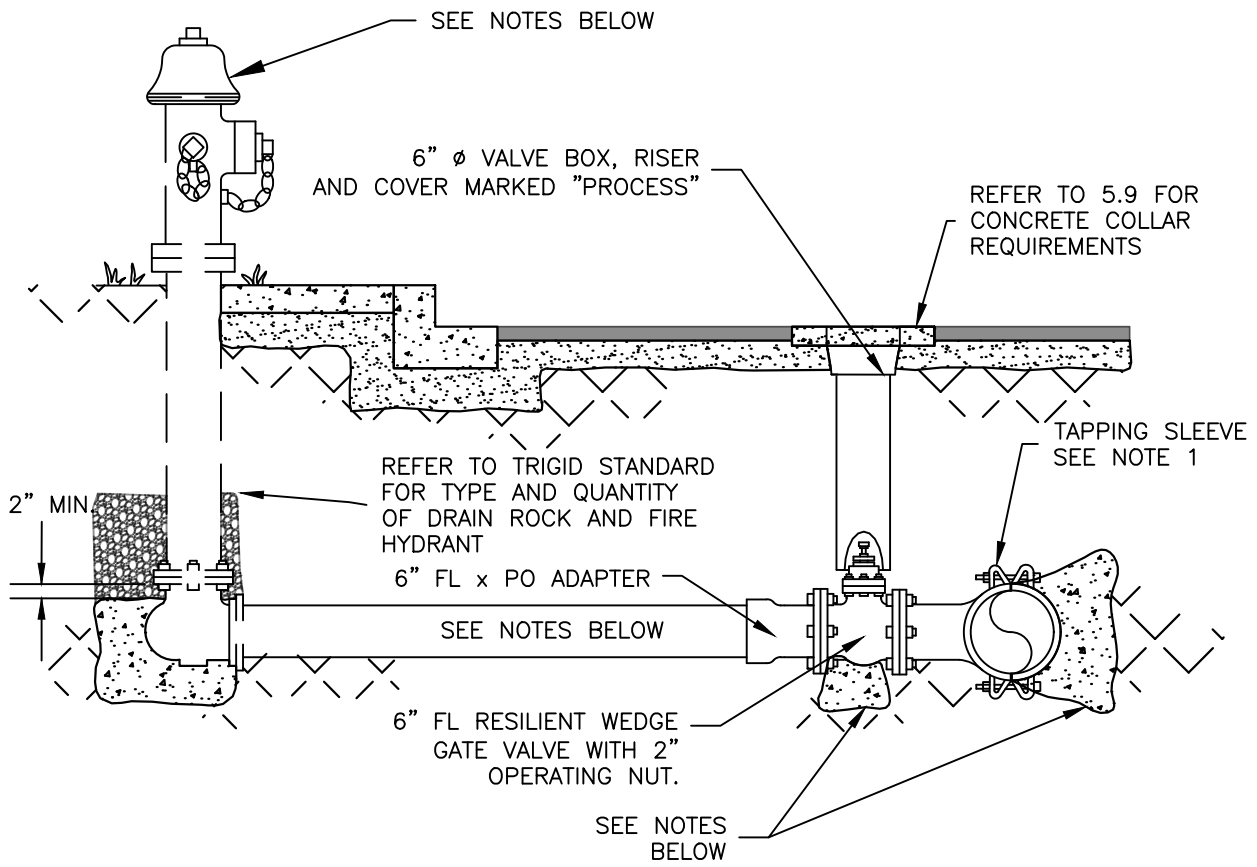

NOTES:

1. REFER TO DETAILS 5.3.1–5.3.3 FOR TAPPING SLEEVE DETAILS.
2. REFERENCE NAC 445A, TRIGID CONSTRUCTION AND DESIGN STANDARDS FOR REQUIRED PIPE MATERIALS. POLYETHYLENE WRAP TO BE USED ON ALL DUCTILE IRON PIPE AND FITTINGS PER AWWA C105.
3. REFER TO PLAN FOR ACTUAL DIAMETER AND LENGTH FOR HYDRANT LATERAL.
4. KEEP A MINIMUM OF 2" CLEARANCE BETWEEN FLANGES/BOLTS AND CONCRETE.
5. LOCATION OF PROCESS HYDRANT TO BE DETERMINED BY TRIGID. PROCESS HYDRANT AND BARREL EXTENSION TO BE SUPPLIED BY OTHERS.
6. REFER TO TRIGID'S ADOPTED FIRE CODE FOR HYDRANT TYPE, COLOR AND CONNECTION TYPES.
7. ALL EXPOSED METAL MUST BE COATED AND WRAPPED.
8. REFER TO TRIGID STANDARDS OR DETAILS 5.13–5.19 FOR THRUST BLOCK REQUIREMENTS. USE THE MOST CONSERVATIVE.
9. PRESSURE TEST TAPPING SLEEVE AND VALVE TO MANUFACTURER'S RECOMMENDATION.

SOURCE: TMWA DETAIL 10F-4

 <p>440 USA PKWY, SUITE 105 McCARRAN, NEVADA 89437</p>	DRAWN: _____ NT CHECKED: _____ CLR REV: _____ MAY 2024 REV: _____	STANDARD DETAIL	PROCESS
	<h2>6" PROCESS HYDRANT SERVICE OFF EXISTING MAIN</h2>		<h3>5.6.3</h3>

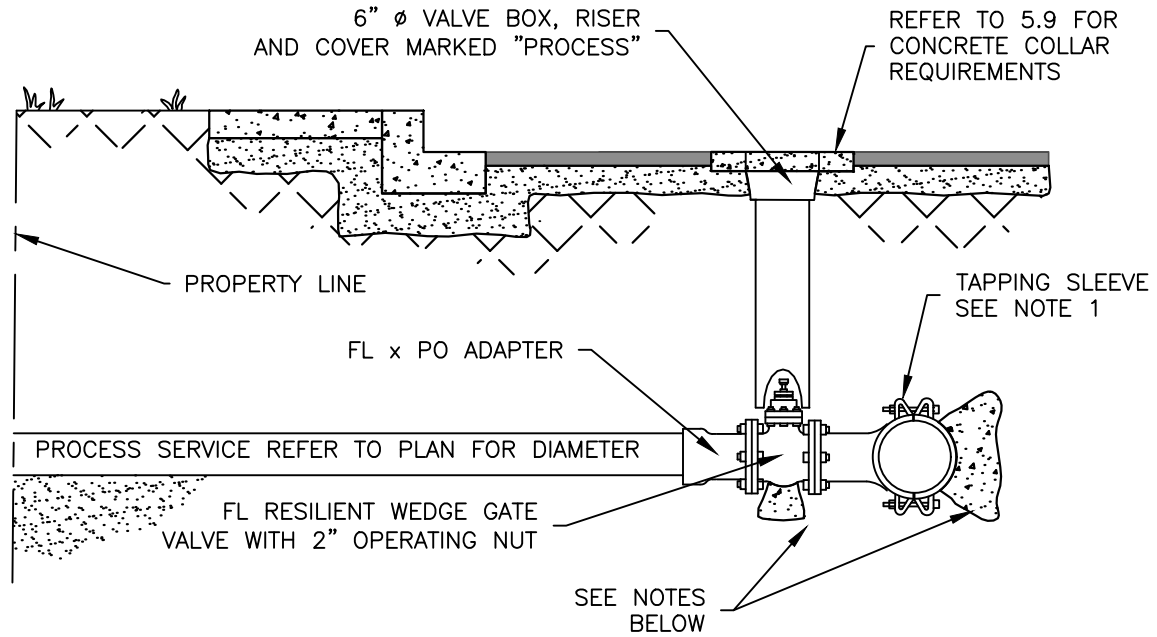

NOTES:

1. REFER TO DETAILS 5.3.1–5.3.3 FOR TAPPING SLEEVE DETAILS.
2. REFERENCE NAC 445A, TRIGID CONSTRUCTION AND DESIGN STANDARDS FOR REQUIRED PIPE MATERIALS. POLYETHYLENE WRAP TO BE USED ON ALL DUCTILE IRON PIPE AND FITTINGS PER AWWA C105.
3. REFER TO PLAN FOR DIAMETER AND LENGTH OF SERVICE LATERAL.
4. KEEP A MINIMUM OF 2" CLEARANCE BETWEEN FLANGES/BOLTS AND CONCRETE.
5. ALL EXPOSED METAL MUST BE COATED AND WRAPPED.
6. REFER TO TRIGID STANDARDS OR DETAILS 5.13–5.19 FOR THRUST BLOCK REQUIREMENTS. USE THE MOST CONSERVATIVE.
7. REFER TO APPROVED PLAN AND DETAILS 5.4.1–5.4.2 FOR APPROPRIATE BACKFLOW DEVICE.
8. PRESSURE TEST TAPPING SLEEVE AND VALVE TO MANUFACTURER'S RECOMMENDATION.

SOURCE: TMWA DETAIL 10F-5

 <p>440 USA PKWY, SUITE 105 McCARRAN, NEVADA 89437</p>	DRAWN: _____ NT CHECKED: _____ CLR REV: _____ MAY 2024 REV: _____	STANDARD DETAIL	PROCESS
	<h2>PROCESS SERVICE OFF EXISTING MAIN</h2>		<h1>5.6.4</h1>



NOTES:

1. SERVICE CLAMP SIZE IS DEPENDENT UPON THE SIZE AND TYPE OF MAIN.
2. SDR-9 CTS HDPE TUBING, LENGTH AND DIAMETER TO BE DETERMINED BY ENGINEER. REFER TO APPROVED PLAN.
3. STOP CORP IP THREAD INLET, COMPRESSION OUTLET, DIAMETER TO MATCH TAP SIZE AS SHOWN ON PLAN.
4. INSERT RIGID STAINLESS STEEL LINER TO SDR-9 CTS HDPE TUBING.
5. SERVICE TAPS OFF OF EXISTING PVC MAINS SHALL USE TAPPED FULL CIRCLE REPAIR CLAMP, MINIMUM LENGTH: 15". MANUFACTURER SHALL BE APPROVED BY TRIGID.

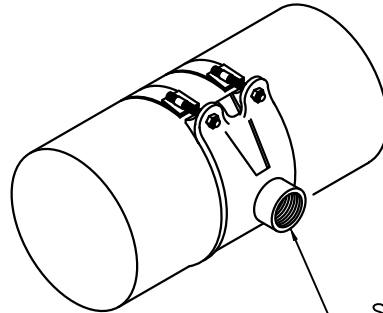
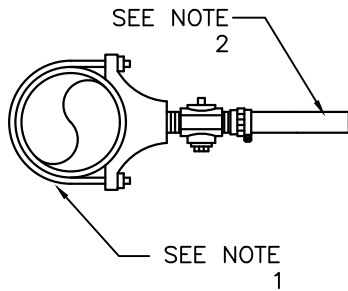

SERVICE SADDLE TO BE CONSTRUCTED OF DUCTILE IRON WITH FUSED NYLON COATING AND DOUBLE STAINLESS STEEL STRAPS. SEE NOTE 5.

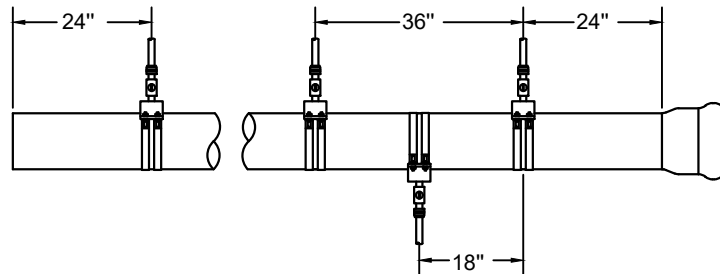

C-900  
PVC  
OR  
TRANSITE

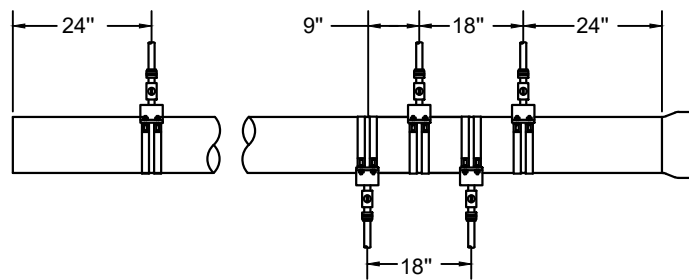

DUCTILE  
OR CAST  
IRON OR  
STEEL

SOURCE: TMWA DETAIL 10H-2



DRAWN: \_\_\_\_\_ NT  
 CHECKED: \_\_\_\_\_ CLR  
 REV: \_\_\_\_\_ MAY 2024  
 REV: \_\_\_\_\_

STANDARD DETAIL

PROCESS

1" TO 2" SERVICE TAP

5.7.1

NOTES:

1. REFERENCE SECTION 2.21 FOR UTILITY SEPARATION REQUIREMENTS.
2. ALL RESTRAINED JOINT PIPING SHALL BE DUCTILE IRON PIPE (RJ-DIP). RESTRAINED LENGTHS OUTSIDE OUTERMOST ELBOWS SHALL BE CALCULATED BY THE DESIGN ENGINEER AND SPECIFIED ON THE WATER IMPROVEMENT PLANS.
3. RESTRAINED JOINT FITTINGS SHALL BE MECHANICAL JOINT (MJ) DUCTILE IRON RESTRAINED WITH MECHANICAL JOINT WEDGE ACTION RESTRAINT GLANDS.
4. BELL AND SPIGOT PUSH-ON JOINTS SHALL BE RESTRAINED USING RUBBER GASKETS WITH STAINLESS STEEL LOCKING SEGMENTS VULCANIZED INTO THE RUBBER GASKET.
5. ALL BOLTS AND EXPOSED METAL SHALL BE COATED WITH BRUSHED-ON MASTIC.
6. FITTINGS, DUCTILE IRON PIPE, AND OTHER METAL PARTS SHALL BE ENCASED WITH POLYETHYLENE WRAP PER AWWA C105.

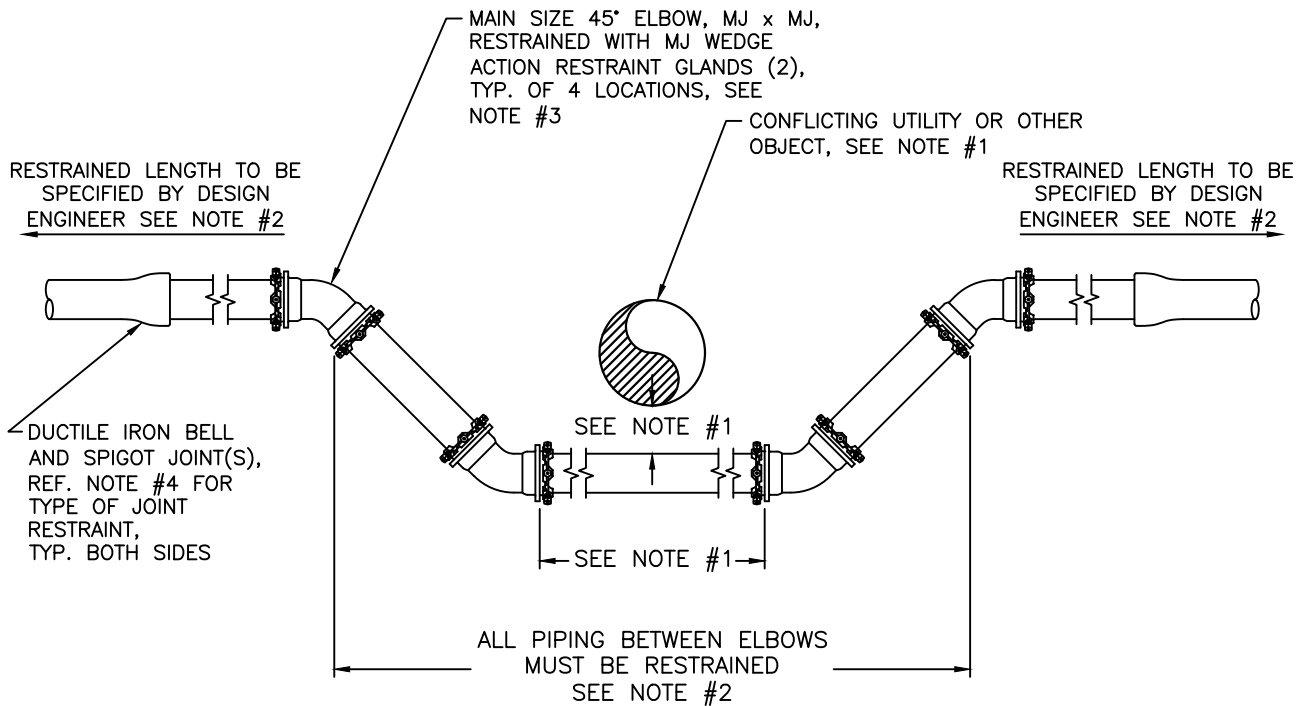

SOURCE: TMWA DETAIL 10I-2



DRAWN: \_\_\_\_\_ NT  
 CHECKED: \_\_\_\_\_ CLR  
 REV: \_\_\_\_\_ MAY 2024  
 REV: \_\_\_\_\_

STANDARD DETAIL

**RESTRAINED JOINT VERTICAL  
 OFFSET UNDER UTILITY/OBJECT**

PROCESS

5.8.1

NOTES:

1. REFERENCE SECTION 2.21 FOR UTILITY SEPARATION REQUIREMENTS.
2. ALL RESTRAINED JOINT PIPING SHALL BE DUCTILE IRON PIPE (RJ-DIP). RESTRAINED LENGTHS OUTSIDE OUTERMOST ELBOWS SHALL BE CALCULATED BY THE DESIGN ENGINEER AND SPECIFIED ON THE WATER IMPROVEMENT PLANS.
3. RESTRAINED JOINT FITTINGS SHALL BE MECHANICAL JOINT (MJ) DUCTILE IRON RESTRAINED WITH MECHANICAL JOINT WEDGE ACTION RESTRAINT GLANDS.
4. BELL AND SPIGOT PUSH-ON JOINTS SHALL BE RESTRAINED USING RUBBER GASKETS WITH STAINLESS STEEL LOCKING SEGMENTS VULCANIZED INTO THE RUBBER GASKET.
5. ALL BOLTS AND EXPOSED METAL SHALL BE COATED WITH BRUSHED-ON MASTIC.
6. FITTINGS, DUCTILE IRON PIPE, AND OTHER METAL PARTS SHALL BE ENCASED WITH POLYETHYLENE WRAP PER AWWA C105.

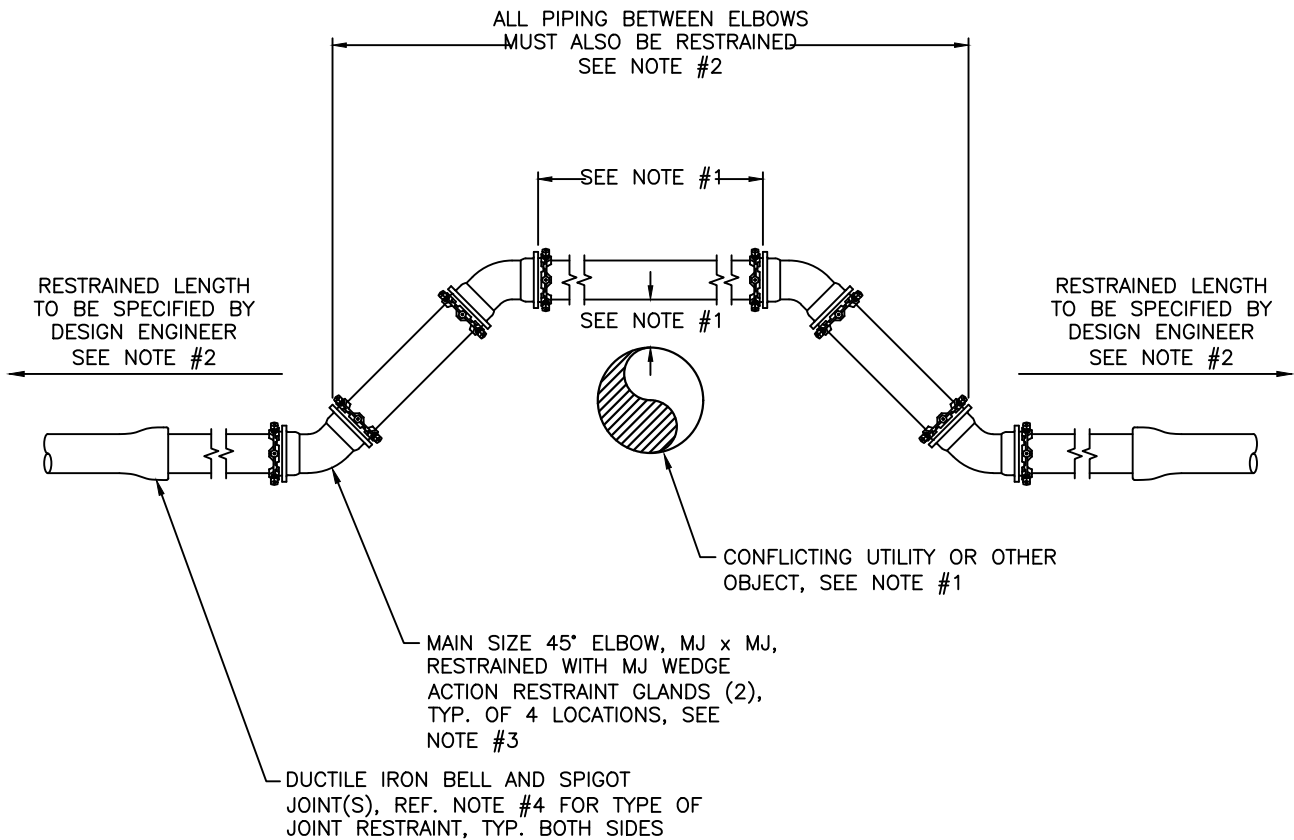

SOURCE: TMWA DETAIL 10I-3



DRAWN: \_\_\_\_\_ NT  
 CHECKED: \_\_\_\_\_ CLR  
 REV: \_\_\_\_\_ MAY 2024  
 REV: \_\_\_\_\_

STANDARD DETAIL

PROCESS

**RESTRAINED JOINT VERTICAL  
 OFFSET OVER UTILITY/OBJECT**

5.8.2

NOTES:

1. REFERENCE SECTION 2.21 FOR UTILITY SEPARATION REQUIREMENTS.
2. ALL RESTRAINED JOINT PIPING SHALL BE DUCTILE IRON PIPE (RJ-DIP). RESTRAINED LENGTHS OUTSIDE OUTERMOST ELBOWS SHALL BE CALCULATED BY THE DESIGN ENGINEER AND SPECIFIED ON THE WATER IMPROVEMENT PLANS.
3. RESTRAINED JOINT FITTINGS SHALL BE MECHANICAL JOINT (MJ) DUCTILE IRON RESTRAINED WITH MECHANICAL JOINT WEDGE ACTION RESTRAINT GLANDS.
4. BELL AND SPIGOT PUSH-ON JOINTS SHALL BE RESTRAINED USING RUBBER GASKETS WITH STAINLESS STEEL LOCKING SEGMENTS VULCANIZED INTO THE RUBBER GASKET.
5. PIPING BETWEEN ELBOWS MUST ALSO BE RESTRAINED.
6. ALL BOLTS AND EXPOSED METAL SHALL BE COATED WITH BRUSHED-ON MASTIC.
7. FITTINGS, DUCTILE IRON PIPE, AND OTHER METAL PARTS SHALL BE ENCASED WITH POLYETHYLENE WRAP PER AWWA C105.

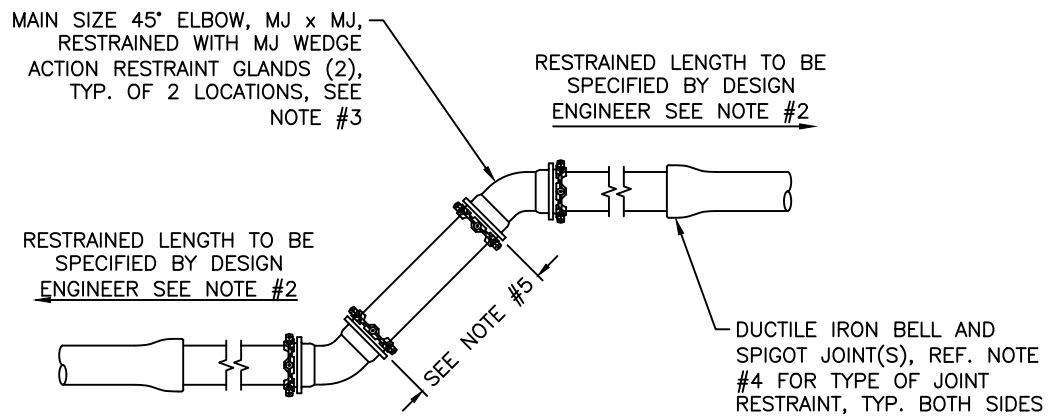

SOURCE: TMWA DETAIL 10I-4

 <p>440 USA PKWY, SUITE 105 McCARRAN, NEVADA 89437</p>	DRAWN: _____ NT CHECKED: _____ CLR REV: _____ MAY 2024 REV: _____	STANDARD DETAIL	PROCESS
	<h2>RESTRAINED JOINT SINGLE VERTICAL OFFSET</h2>		5.8.3

**NOTES:**

1. CONCRETE COLLAR SHALL BE MINIMUM 6-INCHES THICK OR MATCH PAVEMENT THICKNESS, WHICHEVER IS GREATER, UNLESS OTHERWISE SPECIFIED BY THE JURISDICTIONAL AGENCY RESPONSIBLE FOR THE ROADWAY.
2. FOR MULTIPLE VALVE/RISER BOXES IN CLOSE PROXIMITY, A MONOLITHIC CONCRETE COLLAR MAY BE POURED.
3. CONTRACTOR AND/OR DESIGN ENGINEER SHALL CONSULT WITH THE JURISDICTIONAL AGENCY RESPONSIBLE FOR THE ROADWAY FOR REQUIREMENTS THAT MAY VARY FROM THIS STANDARD PRIOR TO CONSTRUCTION.
4. ALL BOLTS AND EXPOSED METAL SHALL BE COATED WITH BRUSHED-ON MASTIC.
5. GATE VALVE, DUCTILE IRON PIPE, AND OTHER METAL PARTS SHALL BE ENCASED WITH POLYETHYLENE WRAP PER AWWA C105.
6. UNLESS OTHERWISE SPECIFIED BY THE JURISDICTIONAL AGENCY RESPONSIBLE FOR THE ROADWAY, PORTLAND CEMENT CONCRETE (P.C.C.) FOR CONCRETE COLLAR SHALL HAVE THE FOLLOWING CHARACTERISTICS: 4,000 PSI MINIMUM COMPRESSIVE STRENGTH AT 28 DAYS, MINIMUM 6 SACKS OF CEMENT PER CUBIC YARD WITH A MAXIMUM WATER/CEMENT RATIO OF 0.45, AIR ENTRAINMENT 6% ±1.5%, SLUMP AT 1 TO 4 INCHES. BAG CONCRETE MIX IS NOT ACCEPTABLE.
7. CONCRETE FOR PAD SHALL HAVE A COMPRESSIVE STRENGTH OF NOT LESS THAN 3,000 PSI AFTER 28 DAYS. BAG CONCRETE MIX IS NOT ACCEPTABLE.

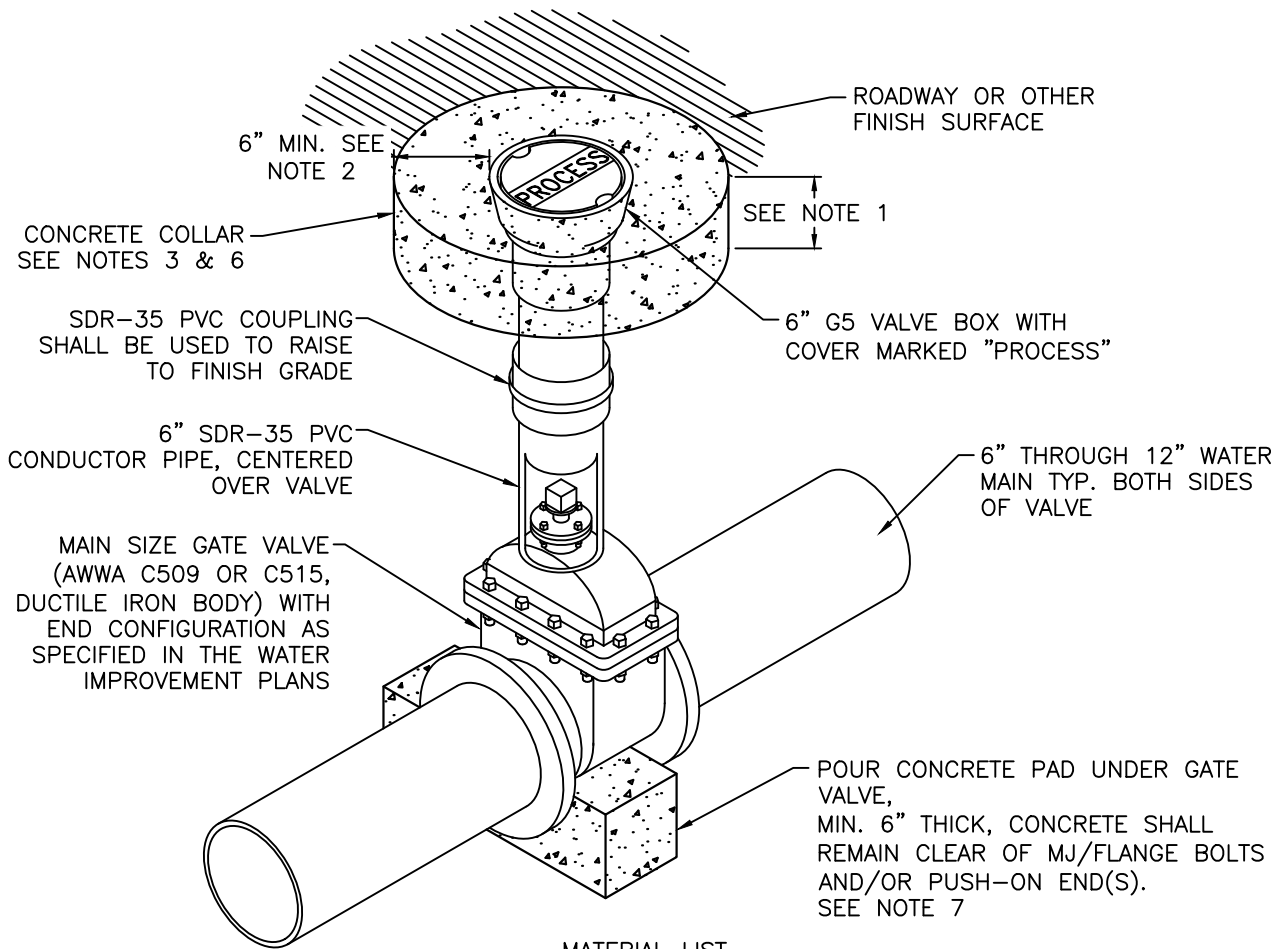

**MATERIAL LIST**

QTY	DESCRIPTION
1	MAIN SIZE GATE VALVE (AWWA C509 OR C515, DUCTILE IRON BODY) WITH END CONFIGURATION AS SPECIFIED IN THE WATER IMPROVEMENT PLANS
1	MASTIC (1 GALLON CAN – BRUSH ON)
1	6" Ø SDR-35 PVC CONDUCTOR PIPE SECTION
1	6" Ø CAST IRON VALVE BOX WITH COVER MARKED "PROCESS"
1	FULL FACE GASKET
1	CONCRETE BULK – PAD AND COLLAR

SOURCE: TMWA DETAIL 10J-2

 TRI-GID 440 USA PKWY, SUITE 105 McCARRAN, NEVADA 89437	DRAWN: _____ NT CHECKED: _____ CLR REV: _____ MAY 2024 REV: _____	STANDARD DETAIL <h2 style="margin: 0;">IN-LINE GATE VALVE WITH CONCRETE COLLAR</h2>	PROCESS <h1 style="margin: 0;">5.9.1</h1>

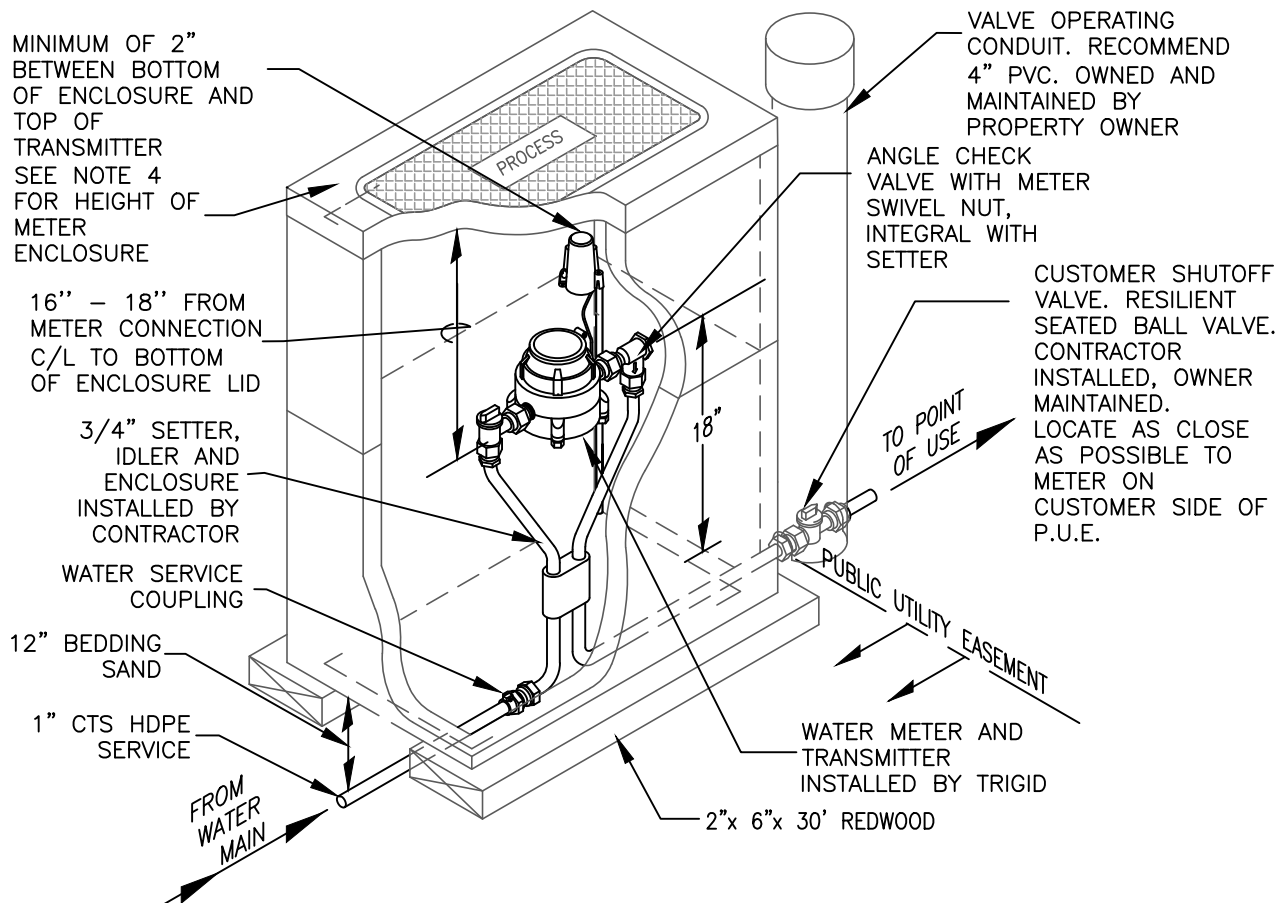

**NOTES:**

1. THERMAL EXPANSION PROTECTION IS REQUIRED IN ANY SUPPLY SYSTEM THAT IS DOWNSTREAM FROM A BACKFLOW PREVENTION DEVICE. REFERENCE: UNIFORM PLUMBING CODE.
2. METER AND TRANSMITTER SUPPLIED BY CONTRACTOR AND INSTALLED BY TRIGID.
3. FOR DRIVEWAY OR TRAFFIC AREAS USE 13X24 ENCLOSURE APPROVED FOR TRAFFIC RATED H/20 LOADING. SEE DETAIL 5.10.10.
4. TOP OF METER ENCLOSURE SHALL BE SET 0.2 FEET ABOVE HIGHEST FINISHED GRADE SURROUNDING ENCLOSURE WITHIN LANDSCAPED AREAS, AND SHALL BE SET FLUSH WITH SURROUNDING FINISH GRADE IN TRAFFIC AREAS.
5. ENCLOSURE TO BE BACKFILLED WITH WATER PIPE BEDDING SAND ONLY, SEE DETAILS 2.17-2.18.
6. BLANKET TO BE INSTALLED ABOVE METER AND BELOW TRANSMITTER.

**MATERIAL LIST**

ITEM ID	QTY.	DESCRIPTION
MS-CHK-0.75	1.0	SETTER WATER METER, WITH ANGLE CHECK VALVE, NEW 3/4" MIP ENDS
WSC-1.00x0.75-CTSxFIP	1.0	COUPLING SERVICE 1" CTS COMPRESSION X 3/4" FIP
SSL-1.00	1.0	LINER RIGID STAINLESS STEEL FOR 1" CTS HDPE TUBING
GSKT-0.75	2.0	GASKET-3/4" FOR WATER METER
WM-DISC-0.75	1.0	3/4" WATER METER - SUPPLIED AND INSTALLED BY CONTRACTOR
ENCL-12x22-NT	1.0	ENCLOSURE NON-TRAFFIC 12 X 22 WATER METERS, SEE NOTE 3
ENCL-12x22-LID-NT	1.0	COVER NON-TRAFFIC 12 X 22, SEE NOTE 3
ENCL-12x22-EXT-NT	1.0	EXTENSION BOX NON-TRAFFIC 12 X 22, SEE NOTE 3
INSL-BLKT-4x4	1.0	BLANKET INSULATION 4' X 4' FOR WATER METERS
RDWD-BRD-2x6x30	2.0	BOARD - REDWOOD 2" X 6" X 30"
IDLR-0.75	1.0	IDLER WATER METER 3/4" SETTER
ERT	1.0	REMOTE TRANSMITTER - SUPPLIED BY CONTRACTOR AND INSTALLED BY TRIGID

SOURCE: TMWA DETAIL 10K-2

 440 USA PKWY, SUITE 105 McCARRAN, NEVADA 89437	DRAWN: _____ NT CHECKED: _____ CLR REV: _____ MAY 2024 REV: _____	STANDARD DETAIL <b>NEW COMMERCIAL INSTALL - 1"          SINGLE SERVICE FOR 3/4" SETTER,          METER, AND TRANSMITTER</b>	PROCESS <b>5.10.1</b>

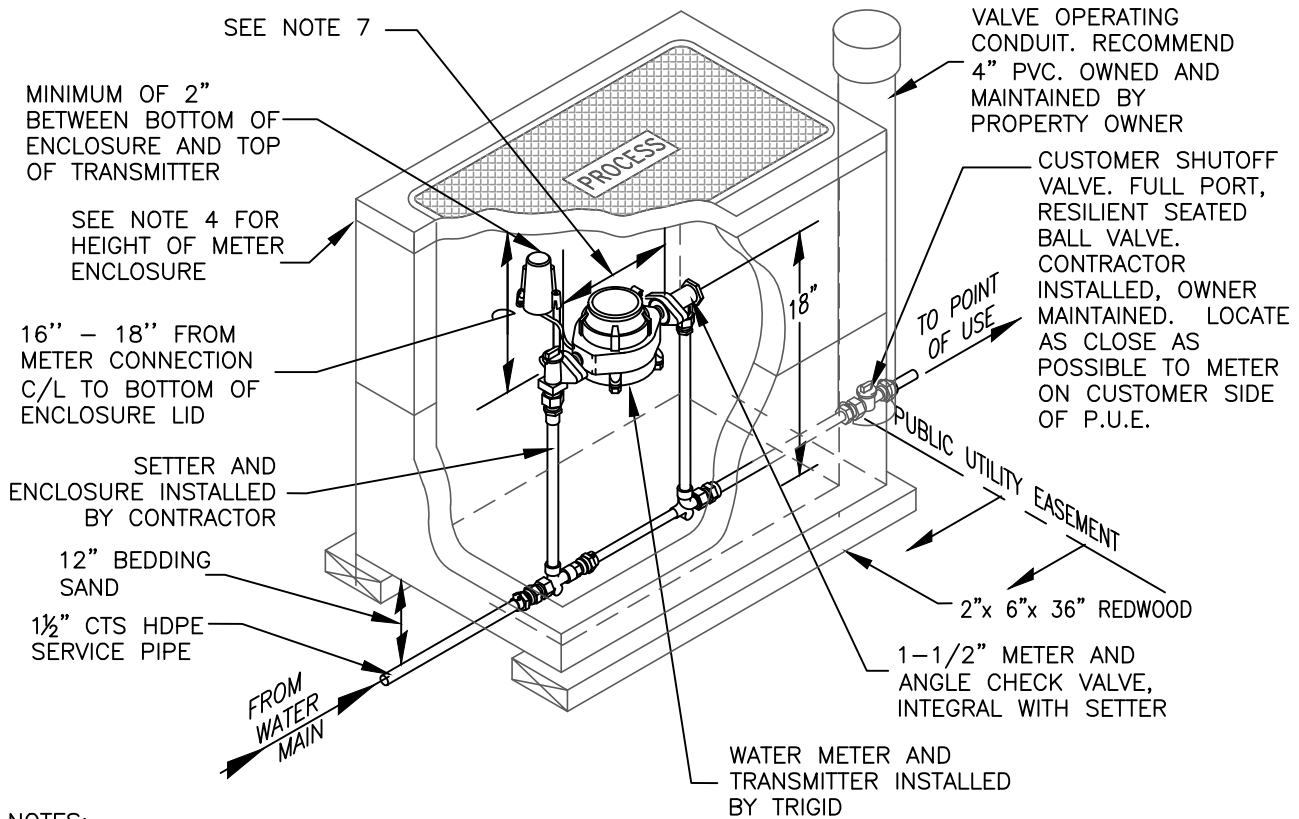

**NOTES:**

1. THERMAL EXPANSION PROTECTION IS REQUIRED IN ANY SUPPLY SYSTEM THAT IS DOWNSTREAM FROM A BACKFLOW PREVENTION DEVICE. REFERENCE: UNIFORM PLUMBING CODE.
2. METER AND TRANSMITTER SUPPLIED BY CONTRACTOR AND INSTALLED BY TRIGID.
3. FOR DRIVEWAY OR TRAFFIC AREAS USE 17X30 ENCLOSURE APPROVED FOR TRAFFIC RATED H/20 LOADING. SEE DETAIL 5.10.11.
4. TOP OF METER ENCLOSURE SHALL BE SET 0.2 FEET ABOVE HIGHEST FINISHED GRADE SURROUNDING ENCLOSURE WITHIN LANDSCAPED AREAS, AND SHALL BE SET FLUSH WITH SURROUNDING FINISH GRADE IN TRAFFIC AREAS.
5. ENCLOSURE TO BE BACKFILLED WITH WATER PIPE BEDDING SAND ONLY, SEE DETAILS 2.17-2.18.
6. BLANKET TO BE INSTALLED ABOVE METER AND BELOW TRANSMITTER.
7. DISTANCE BETWEEN FLANGES SHALL BE 13.25".

MATERIAL LIST

ITEM ID	QTY.	DESCRIPTION
MS-CHK-1.50	1.0	SETTER WATER METER, WITH ANGLE CHECK VALVE, NEW 1-1/2" FIP ENDS
WSC-1.50x1.50-CTSxMIP	1.0	COUPLING SERVICE 1-1/2" CTS COMPRESSION X 1-1/2" MIP
SSL-1.50	1.0	LINER RIGID STAINLESS STEEL FOR 1-1/2" CTS HDPE TUBING
GSKT-1.50	2.0	GASKET-1-1/2" FOR WATER METER
WM-DISC-1.50	1.0	1-1/2" WATER METER - SUPPLIED AND INSTALLED BY CONTRACTOR
ENCL-17x30-NT	1.0	ENCLOSURE NON-TRAFFIC 17 X 30 WATER METERS, SEE NOTE 2
ENCL-17x30-LID-NT	1.0	COVER NON-TRAFFIC 17 X 30, NON CONCRETE FIBRELYTE LID, SEE NOTE 2
ENCL-17x30-EXT-NT	1.0	EXTENSION BOX NON-TRAFFIC 17 X 30, SEE NOTE 2
INSL-BLKT-4x4	1.0	BLANKET INSULATION 4' X 4' FOR WATER METERS
RDWD-BRD-2X6X36	2.0	BOARD - REDWOOD 2" X 6" X 36"
IDLR-1.50	1.0	IDLER WATER METER 1-1/2" SETTER
BOLTS	4.0	BOLT COPPER #651 SILICONE BRONZE 5/8" X 2-1/2" WITH 2 FLAT WASHERS & NUTS
ERT	1.0	REMOTE TRANSMITTER - SUPPLIED BY CONTRACTOR AND INSTALLED BY TRIGID

SOURCE: TMWA DETAIL 10K-4

 440 USA PKWY, SUITE 105 McCARRAN, NEVADA 89437	DRAWN: _____ NT CHECKED: _____ CLR REV: _____ MAY 2024 REV: _____	STANDARD DETAIL <b>NEW COMMERCIAL INSTALL - 1 1/2"          SINGLE SERVICE FOR 1/2" SETTER,          METER, AND TRANSMITTER</b>	PROCESS <b>5.10.2</b>



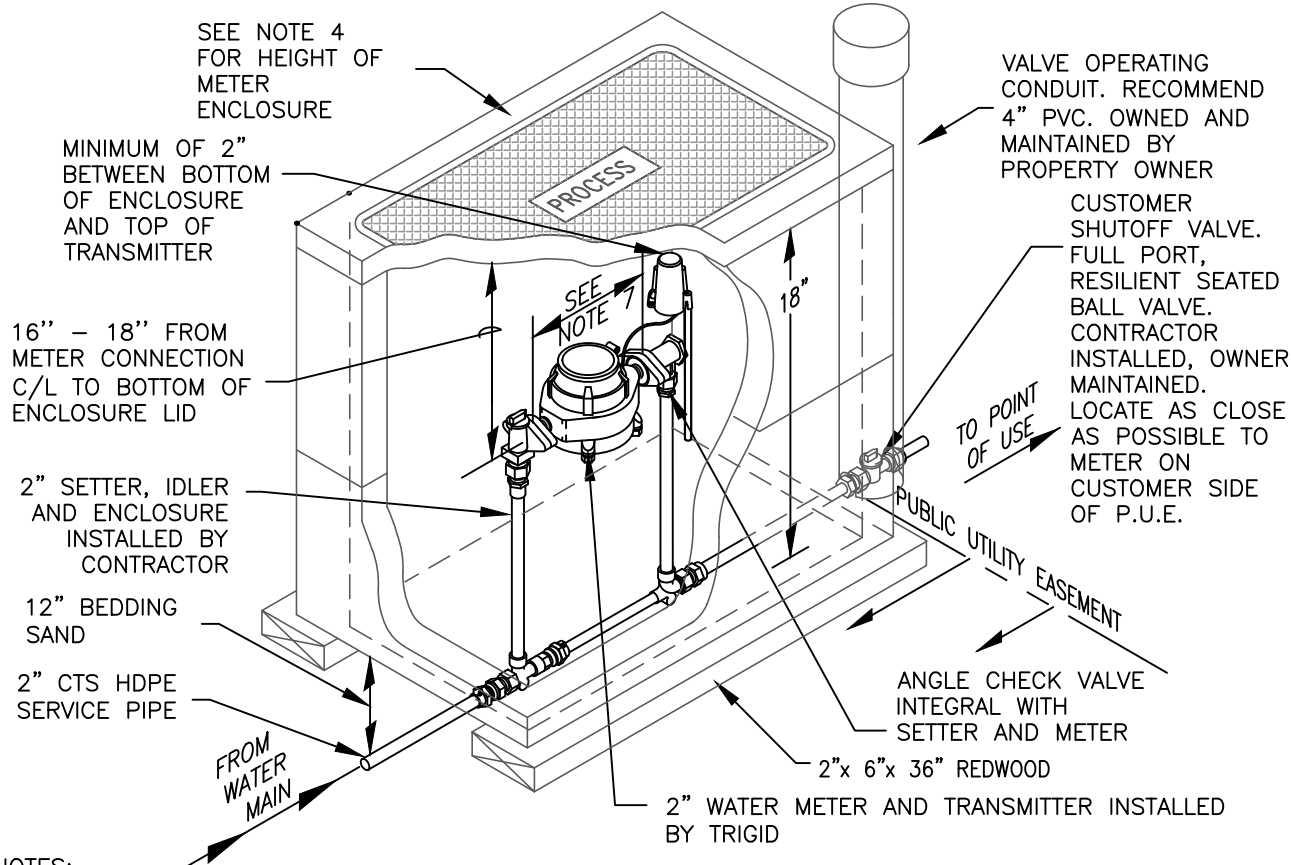

**NOTES:**

1. THERMAL EXPANSION PROTECTION IS REQUIRED IN ANY SUPPLY SYSTEM THAT IS DOWNSTREAM FROM A BACKFLOW PREVENTION DEVICE. REFERENCE: UNIFORM PLUMBING CODE.
2. METER AND TRANSMITTER SUPPLIED BY CONTRACTOR AND INSTALLED BY TRIGID.
3. FOR DRIVEWAY OR TRAFFIC AREAS USE 17X30 ENCLOSURE APPROVED FOR TRAFFIC RATED H/20 LOADING. SEE DETAIL 5.10.11.
4. TOP OF METER ENCLOSURE SHALL BE SET 0.2 FEET ABOVE HIGHEST FINISHED GRADE SURROUNDING ENCLOSURE WITHIN LANDSCAPED AREAS, AND SHALL BE SET FLUSH WITH SURROUNDING FINISH GRADE IN TRAFFIC AREAS.
5. ENCLOSURE TO BE BACKFILLED WITH WATER PIPE BEDDING SAND ONLY, SEE DETAILS 2.17-2.18.
6. BLANKET TO BE INSTALLED ABOVE METER AND BELOW TRANSMITTER.
7. DISTANCE BETWEEN FLANGES SHALL BE 17.25".

**MATERIAL LIST**

ITEM ID	QTY.	DESCRIPTION
MS-CHK-2.00	1.0	SETTER WATER METER, WITH ANGLE CHECK VALVE, NEW 2" FIP ENDS
WSC-2.00x2.00-CTSxMIP	1.0	COUPLING SERVICE 2" CTS COMPRESSION X 2" MIP
SSL-2.00	1.0	LINER RIGID STAINLESS STEEL FOR 2" CTS HDPE TUBING
GSKT-2.00	2.0	GASKET-2" FOR WATER METER
WM-DISC-2.00	1.0	2" WATER METER - SUPPLIED AND INSTALLED BY CONTRACTOR
ENCL-17x30-NT	1.0	ENCLOSURE NON-TRAFFIC 17 X 30 WATER METERS, SEE NOTE 3
ENCL-17x30-LID-NT	1.0	COVER NON-TRAFFIC 17 X 30, NON CONCRETE FIBRELYTE LID, SEE NOTE 3
ENCL-17x30-EXT-NT	1.0	EXTENSION BOX NON-TRAFFIC 17 X 30, SEE NOTE 3
INSL-BLKT-4x4	1.0	BLANKET INSULATION 4' X 4' FOR WATER METERS
RDWD-BRD-2X6X36	2.0	BOARD - REDWOOD 2" X 6" X 36"
IDLR-2.00	1.0	IDLER WATER METER 2" SETTER
BOLTS	4.0	BOLT COPPER #651 SILICONE BRONZE 5/8" X 2-1/2" WITH 2 FLAT WASHERS & NUTS
ERT	1.0	REMOTE TRANSMITTER - SUPPLIED BY CONTRACTOR AND INSTALLED BY TRIGID

SOURCE: TMWA DETAIL 10K-5

 440 USA PKWY, SUITE 105 McCARRAN, NEVADA 89437	DRAWN: _____ NT CHECKED: _____ CLR REV: _____ MAY 2024 REV: _____	STANDARD DETAIL <b>NEW COMMERCIAL INSTALL - 2"          SINGLE SERVICE FOR 2" SETTER,          METER, AND TRANSMITTER</b>	PROCESS <b>5.10.3</b>

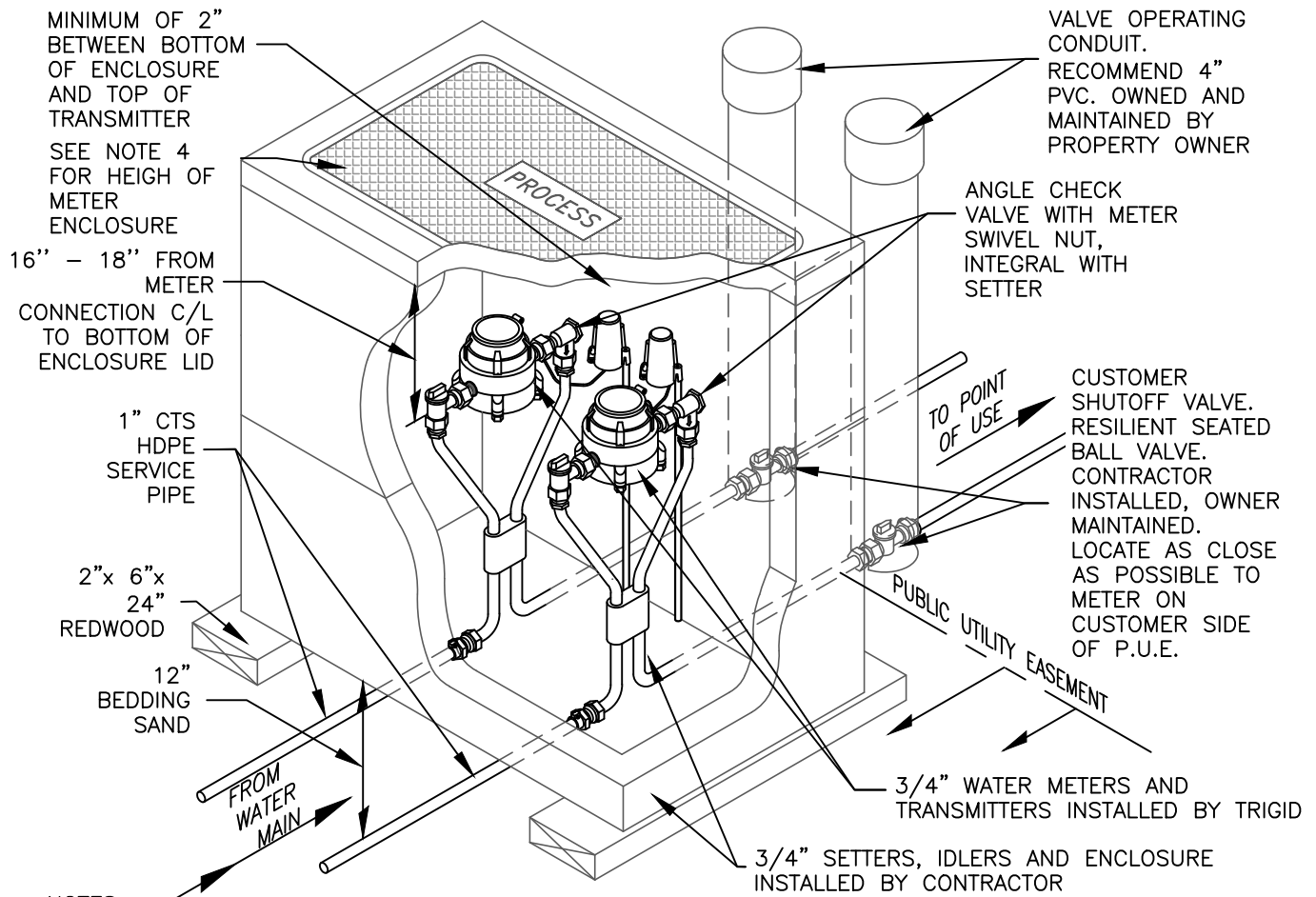

**NOTES:**

1. THERMAL EXPANSION PROTECTION IS REQUIRED IN ANY SUPPLY SYSTEM THAT IS DOWNSTREAM FROM A BACKFLOW PREVENTION DEVICE. REFERENCE: UNIFORM PLUMBING CODE.
2. METER AND TRANSMITTER SUPPLIED BY CONTRACTOR AND INSTALLED BY TRIGID.
3. FOR DRIVEWAY OR TRAFFIC AREAS USE 17X30 ENCLOSURE APPROVED FOR TRAFFIC RATED H/20 LOADING. SEE DETAIL 5.10.11.
4. TOP OF METER ENCLOSURE SHALL BE SET 0.2 FEET ABOVE HIGHEST FINISHED GRADE SURROUNDING ENCLOSURE WITHIN LANDSCAPED AREAS, AND SHALL BE SET FLUSH WITH SURROUNDING FINISH GRADE IN TRAFFIC AREAS.
5. ENCLOSURE TO BE BACKFILLED WITH WATER PIPE BEDDING SAND ONLY, SEE DETAILS 2.17-2.18.
6. BLANKET TO BE INSTALLED ABOVE METER AND BELOW TRANSMITTER.

**MATERIAL LIST**

ITEM ID	QTY.	DESCRIPTION
MS-CHK-0.75	2.0	SETTER WATER METER, WITH ANGLE CHECK VALVE, NEW 3/4" MIP ENDS
WSC-1.00x0.75-CTSxFIP	2.0	COUPLING SERVICE 1" CTS COMPRESSION X 3/4" FIP
SSL-1.00	2.0	LINER RIGID STAINLESS STEEL FOR 1" CTS HDPE TUBING
GSKT-0.75	4.0	GASKET-3/4" FOR WATER METER
WM-DISC-0.75	2.0	3/4" WATER METER - SUPPLIED AND INSTALLED BY CONTRACTOR
ENCL-17x30-NT	1.0	ENCLOSURE NON-TRAFFIC 17 X 30 WATER METERS, SEE NOTE 3
ENCL-17x30-LID-NT	1.0	COVER NON-TRAFFIC 17 X 30, NON CONCRETE FIBRELYTE LID, SEE NOTE 3
ENCL-17x30-EXT-NT	1.0	EXTENSION BOX NON-TRAFFIC 17 X 30, SEE NOTE 3
INSL-BLKT-4x4	1.0	BLANKET INSULATION 4' X 4' FOR WATER METERS
RDWD-BRD-2x6x24	2.0	BOARD - REDWOOD 2" X 6" X 24"
IDLR-0.75	2.0	IDLER WATER METER 3/4" SETTER
ERT	2.0	REMOTE TRANSMITTER - SUPPLIED BY CONTRACTOR AND INSTALLED BY TRIGID

SOURCE: TMWA DETAIL 10K-6

 440 USA PKWY, SUITE 105 McCARRAN, NEVADA 89437	DRAWN: _____ NT CHECKED: _____ CLR REV: _____ MAY 2024 REV: _____	STANDARD DETAIL  <b>NEW COMMERCIAL INSTALL - 1"          DUAL SERVICE FOR 3/4" SETTER,          METER, AND TRANSMITTER</b>	PROCESS  <b>5.10.4</b>

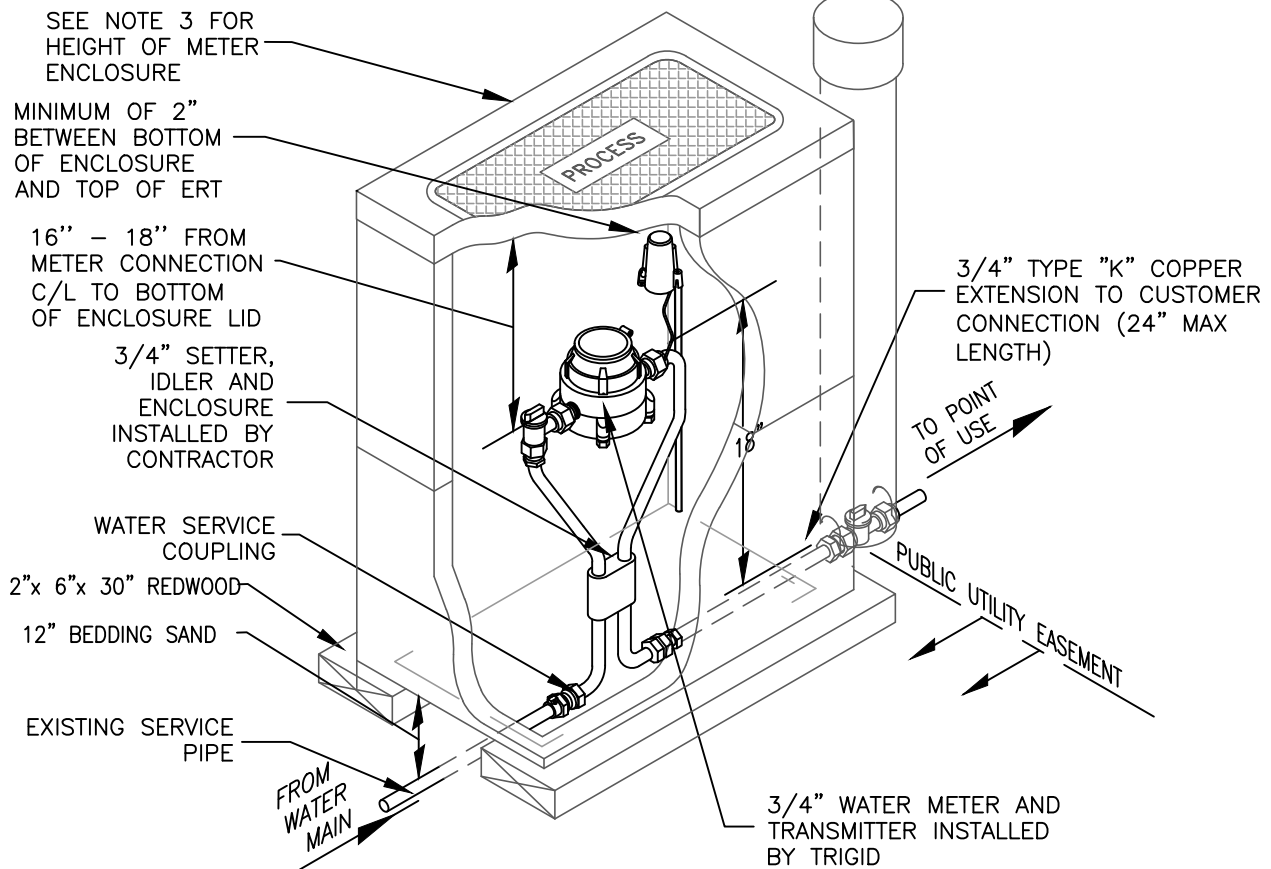

**NOTES:**

1. METER AND TRANSMITTER SUPPLIED BY CONTRACTOR AND INSTALLED BY TRIGID.
2. FOR DRIVEWAY OR TRAFFIC AREAS USE 13X24 ENCLOSURE APPROVED FOR TRAFFIC RATED H/20 LOADING. SEE DETAIL 5.10.10.
3. TOP OF METER ENCLOSURE SHALL BE SET 0.2 FEET ABOVE HIGHEST FINISHED GRADE SURROUNDING ENCLOSURE WITHIN LANDSCAPED AREAS, AND SHALL BE SET FLUSH WITH SURROUNDING FINISH GRADE IN TRAFFIC AREAS.
4. ENCLOSURE TO BE BACKFILLED WITH WATER PIPE BEDDING SAND ONLY, SEE DETAILS 2.17-2.18.
5. BLANKET TO BE INSTALLED ABOVE METER AND BELOW TRANSMITTER.
6. IF SERVICE LINE IS IRON PIPE, GALVANIZED OR BARE STEEL, INSTALL A DIELECTRIC UNION ON THE SETTER. USE A MALE ADAPTER TO CONNECT THE SERVICE LINE. COAT THE ADAPTER AND ONE FOOT OF SERVICE LINE WITH MASTIC.

**MATERIAL LIST**

ITEM ID	QTY.	DESCRIPTION
MS-0.75-RETRO	1.0	SETTER WATER METER
-	1.0	COUPLING SERVICE - BASED ON EXISTING SERVICE X 3/4" FIP
SSL-1.00	1.0	LINER RIGID STAINLESS STEEL FOR 1" CTS HDPE TUBING
GSKT-0.75	2.0	GASKET-3/4" FOR WATER METER
WM-DISC-0.75	1.0	3/4" WATER METER - SUPPLIED AND INSTALLED BY CONTRACTOR
ENCL-12x22-NT	1.0	ENCLOSURE NON-TRAFFIC 12 X 22 WATER METERS, SEE NOTE 2
ENCL-12x22-LID-NT	1.0	COVER NON-TRAFFIC 12 X 22, SEE NOTE 2
ENCL-12x22-EXT-NT	1.0	EXTENSION BOX NON-TRAFFIC 12 X 22, SEE NOTE 2
INSL-BLKT-4x4	1.0	BLANKET INSULATION 4' X 4' FOR WATER METERS
RDWD-BRD-2x6x30	2.0	BOARD - REDWOOD 2" X 6" X 30"
IDLR-0.75	1.0	IDLER WATER METER 3/4" SETTER
ERT	1.0	REMOTE TRANSMITTER - SUPPLIED BY CONTRACTOR AND INSTALLED BY TRIGID

SOURCE: TMWA DETAIL 10K-12

 440 USA PKWY, SUITE 105 McCARRAN, NEVADA 89437	DRAWN: _____ NT	STANDARD DETAIL	PROCESS
	CHECKED: _____ CLR	<b>RETROFIT INSTALL - 1" SINGLE          SERVICE FOR 3/4" SETTER, METER,          AND TRANSMITTER</b>	<b>5.10.5</b>
REV: _____ MAY 2024	REV: _____		

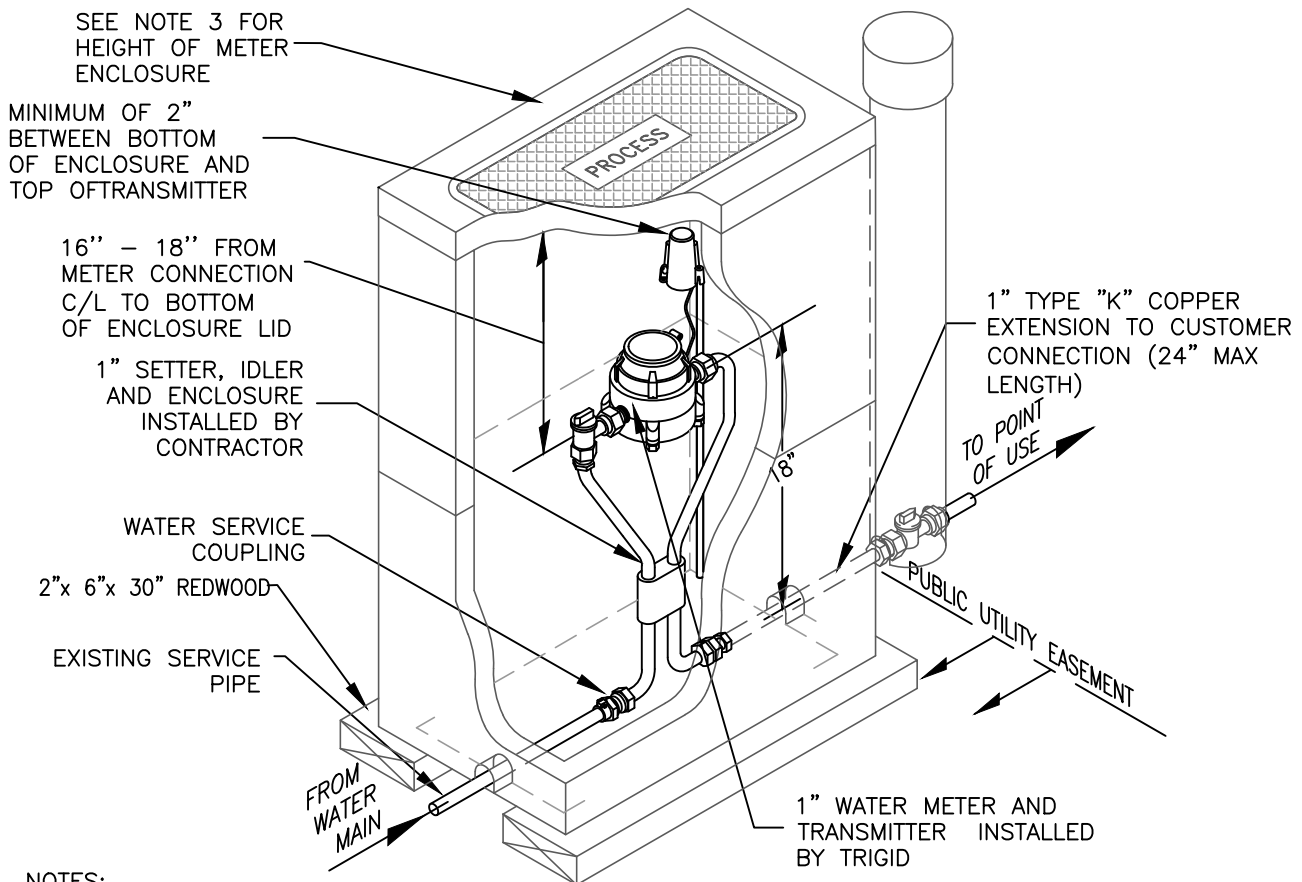

**NOTES:**

1. METER AND TRANSMITTER SUPPLIED BY CONTRACTOR AND INSTALLED BY TRIGID.
2. FOR DRIVEWAY OR TRAFFIC AREAS USE 13X24 ENCLOSURE APPROVED FOR TRAFFIC RATED H/20 LOADING. SEE DETAIL 5.10.10.
3. TOP OF METER ENCLOSURE SHALL BE SET 0.2 FEET ABOVE HIGHEST FINISHED GRADE SURROUNDING ENCLOSURE WITHIN LANDSCAPED AREAS, AND SHALL BE SET FLUSH WITH SURROUNDING FINISH GRADE IN TRAFFIC AREAS.
4. ENCLOSURE TO BE BACKFILLED WITH WATER PIPE BEDDING SAND ONLY, SEE DETAILS 2.17-2.18.
5. BLANKET TO BE INSTALLED ABOVE METER AND BELOW TRANSMITTER.
6. IF SERVICE LINE IS IRON PIPE, GALVANIZED OR BARE STEEL, INSTALL A DIELECTRIC UNION ON THE SETTER. USE A MALE ADAPTER TO CONNECT THE SERVICE LINE. COAT THE ADAPTER AND ONE FOOT OF SERVICE LINE WITH MASTIC.

MATERIAL LIST

ITEM ID	QTY.	DESCRIPTION
MS-1.00-RETRO	1.0	SETTER WATER METER
-	1.0	COUPLING SERVICE - BASED ON EXISTING SERVICE X 1" FIP
SSL-1.25	1.0	LINER RIGID STAINLESS STEEL FOR 1-1/4" CTS HDPE TUBING
GSKT-1.00	2.0	GASKET-1" FOR WATER METER
WM-DISC-1.00	1.0	1" WATER METER - SUPPLIED AND INSTALLED BY CONTRACTOR
ENCL-13x24-NT	1.0	ENCLOSURE NON-TRAFFIC 13 X 24 WATER METERS, SEE NOTE 2
ENCL-13 X 24-LID-NT	1.0	COVER NON-TRAFFIC 13 X 24, SEE NOTE 2
ENCL-13 X 24-EXT-NT	1.0	EXTENSION BOX NON-TRAFFIC 13 X 24, SEE NOTE 2
INSL-BLKT-4x4	1.0	BLANKET INSULATION 4' X 4' FOR WATER METERS
RDWD-BRD-2x6x30	2.0	BOARD - REDWOOD 2" X 6" X 30"
IDLR-1.00	1.0	IDLER WATER METER 1" SETTER
ERT	1.0	REMOTE TRANSMITTER - SUPPLIED BY CONTRACTOR AND INSTALLED BY TRIGID

SOURCE: TMWA DETAIL 10K-13

 440 USA PKWY, SUITE 105 McCARRAN, NEVADA 89437	DRAWN: _____ NT CHECKED: _____ CLR REV: _____ MAY 2024 REV: _____	STANDARD DETAIL <b>RETROFIT INSTALL - 1/4" SINGLE          SERVICE FOR 1" SETTER, METER,          AND TRANSMITTER</b>	PROCESS <b>5.10.6</b>

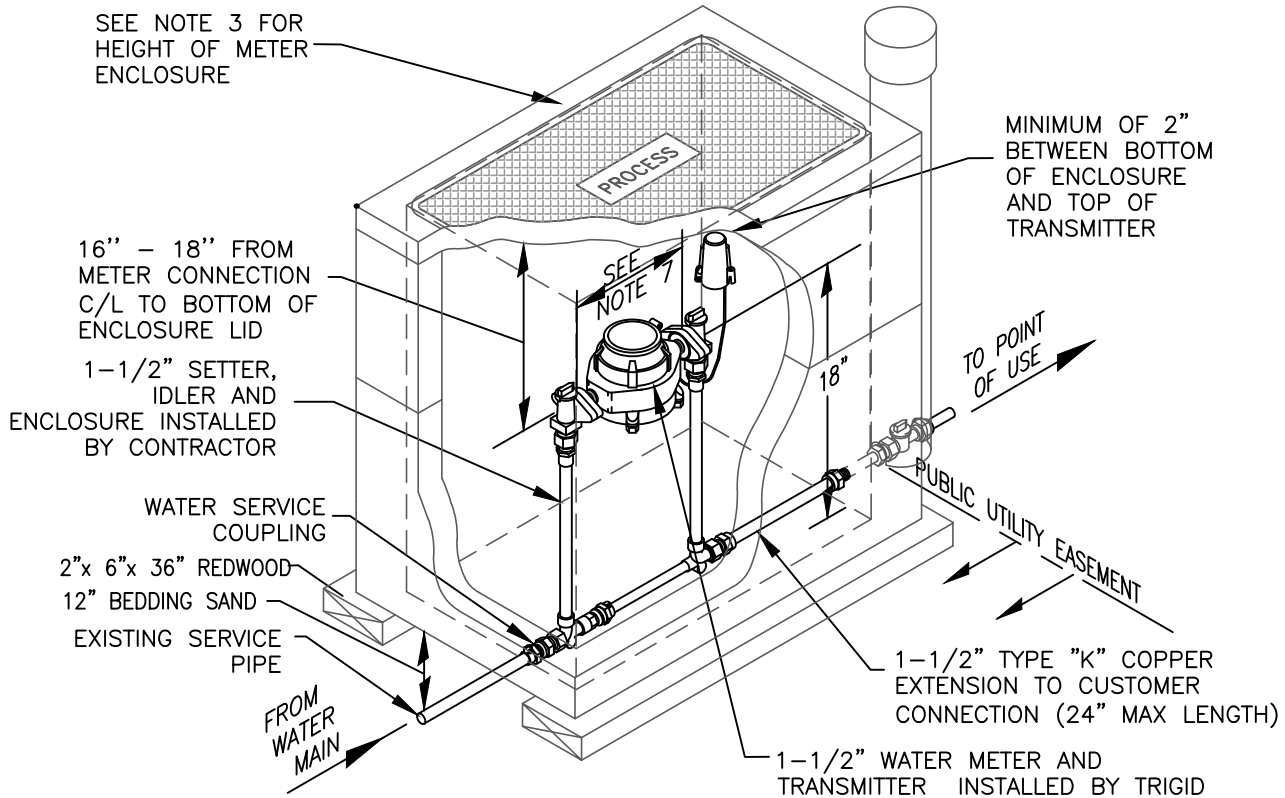

**NOTES:**

1. METER AND TRANSMITTER SUPPLIED BY CONTRACTOR AND INSTALLED BY TRIGID.
2. FOR DRIVEWAY OR TRAFFIC AREAS USE 17X30 ENCLOSURE APPROVED FOR TRAFFIC RATED H/20 LOADING. SEE DETAIL 5.10.11.
3. TOP OF METER ENCLOSURE SHALL BE SET 0.2 FEET ABOVE HIGHEST FINISHED GRADE SURROUNDING ENCLOSURE WITHIN LANDSCAPED AREAS, AND SHALL BE SET FLUSH WITH SURROUNDING FINISH GRADE IN TRAFFIC AREAS.
4. ENCLOSURE TO BE BACKFILLED WITH WATER PIPE BEDDING SAND ONLY, SEE DETAILS 2.17-2.18.
5. BLANKET TO BE INSTALLED ABOVE METER AND BELOW TRANSMITTER.
6. IF SERVICE LINE IS IRON PIPE, GALVANIZED OR BARE STEEL, INSTALL A DIELECTRIC UNION ON THE SETTER. USE A MAKE ADAPTER TO CONNECT THE SERVICE LINE. COAT THE ADAPTER AND ONE FOOT OF SERVICE LINE WITH MASTIC.
7. DISTANCE BETWEEN FLANGES SHALL BE 13.25".

**MATERIAL LIST**

ITEM ID	QTY.	DESCRIPTION
MS-1.50-RETRO	1.0	SETTER WATER METER
-	1.0	COUPLING SERVICE - BASED ON EXISTING SERVICE X 1-1/2" MIP
SSL-1.50	1.0	LINER RIGID STAINLESS STEEL FOR 1-1/2" CTS HDPE TUBING
GSKT-1.50	2.0	GASKET-1-1/2" FOR WATER METER
WM-DISC-1.50	1.0	1-1/2" WATER METER - SUPPLIED AND INSTALLED BY CONTRACTOR
ENCL-17x30-NT	1.0	ENCLOSURE NON-TRAFFIC 17 X 30 WATER METERS, SEE NOTE 2
ENCL-17x30-LID-NT	1.0	COVER NON-TRAFFIC 17 X 30, NON CONCRETE FIBRELYTE LID, SEE NOTE 2
ENCL-17x30-EXT-NT	1.0	EXTENSION BOX NON-TRAFFIC 17 X 30, SEE NOTE 2
INSL-BLKT-4x4	1.0	BLANKET INSULATION 4' X 4' FOR WATER METERS
RDWD-BRD-2X6X36	2.0	BOARD - REDWOOD 2" X 6" X 36"
IDLR-1.50	1.0	IDLER WATER METER 1-1/2" SETTER
BOLTS	4.0	BOLT COPPER #651 SILICONE BRONZE 5/8" X 2-1/2" WITH 2 FLAT WASHERS & NUTS
ERT	1.0	REMOTE TRANSMITTER - SUPPLIED BY CONTRACTOR AND INSTALLED BY TRIGID

SOURCE: TMWA DETAIL 10K-14

 440 USA PKWY, SUITE 105 McCARRAN, NEVADA 89437	DRAWN: _____ NT CHECKED: _____ CLR REV: _____ MAY 2024 REV: _____	STANDARD DETAIL <b>NEW COMMERCIAL INSTALL - 2"          SINGLE SERVICE FOR 2" SETTER,          METER, AND TRANSMITTER</b>	PROCESS <b>5.10.7</b>



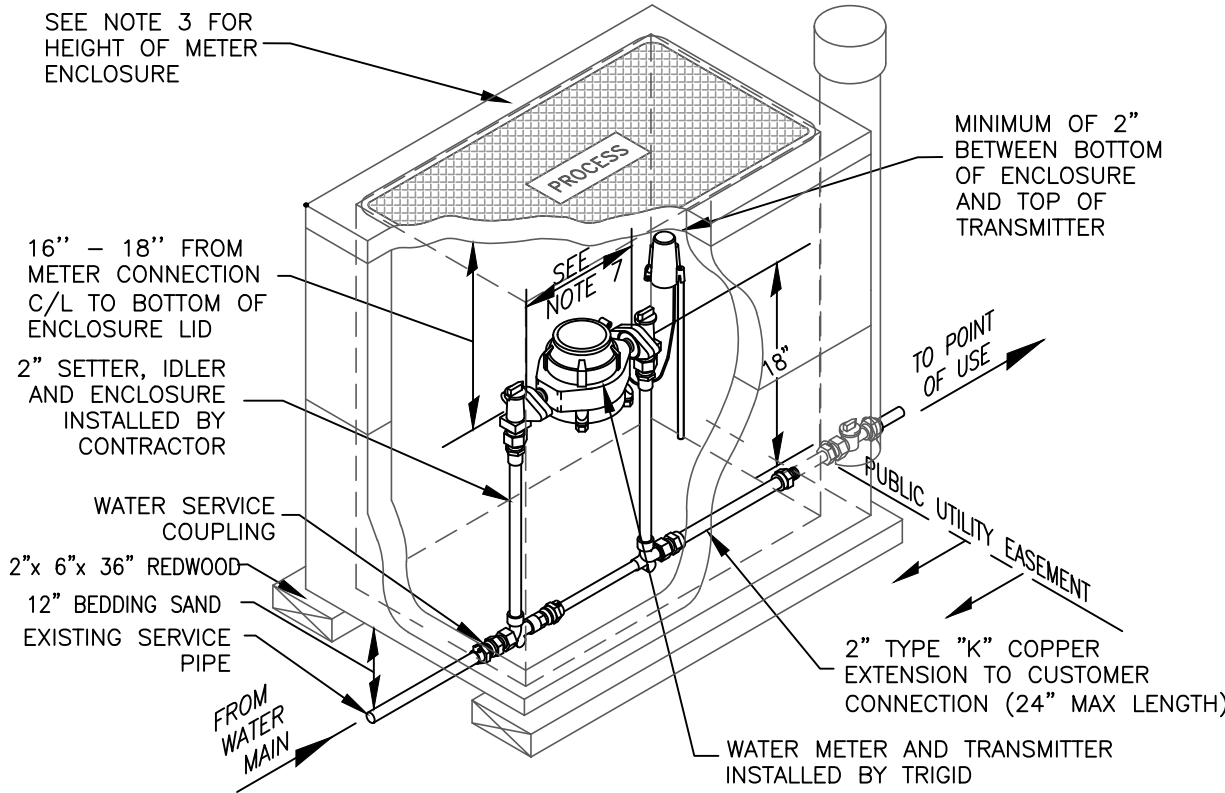

- NOTES:**
- METER AND TRANSMITTER SUPPLIED BY CONTRACTOR AND INSTALLED BY TRIGID.
  - FOR DRIVEWAY OR TRAFFIC AREAS USE 17X30 ENCLOSURE APPROVED FOR TRAFFIC RATED H/20 LOADING. SEE DETAIL 5.10.11.
  - TOP OF METER ENCLOSURE SHALL BE SET 0.2 FEET ABOVE HIGHEST FINISHED GRADE SURROUNDING ENCLOSURE WITHIN LANDSCAPED AREAS, AND SHALL BE SET FLUSH WITH SURROUNDING FINISH GRADE IN TRAFFIC AREAS.
  - ENCLOSURE TO BE BACKFILLED WITH WATER PIPE BEDDING SAND ONLY, SEE DETAILS 2.17-2.18 BLANKET TO BE INSTALLED ABOVE METER AND BELOW TRANSMITTER.
  - IF SERVICE LINE IS IRON PIPE, GALVANIZED OR BARE STEEL, INSTALL A DIELECTRIC UNION ON THE SETTER. USE A MALE ADAPTER TO CONNECT THE SERVICE LINE. COAT THE ADAPTER AND ONE FOOT OF SERVICE LINE WITH MASTIC.
  - DISTANCE BETWEEN FLANGES SHALL BE 17.25".

MATERIAL LIST

ITEM ID	QTY.	DESCRIPTION
MS-2.00-RETRO	1.0	SETTER WATER METER
-	1.0	COUPLING SERVICE - BASED ON EXISTING SERVICE X 2" MIP
SSL-2.00	1.0	LINER RIGID STAINLESS STEEL FOR 2" CTS HDPE TUBING
GSKT-2.00	2.0	GASKET- 2" FOR WATER METER
WM-DISC-2.00	1.0	2" WATER METER - SUPPLIED AND INSTALLED BY CONTRACTOR
ENCL-17x30-NT	1.0	ENCLOSURE NON-TRAFFIC 17 X 30 WATER METERS, SEE NOTE 2
ENCL-17x30-LID-NT	1.0	COVER NON-TRAFFIC 17 X 30, NON CONCRETE FIBRELYTE LID, SEE NOTE 2
ENCL-17x30-EXT-NT	1.0	EXTENSION BOX NON-TRAFFIC 17 X 30, SEE NOTE 2
INSL-BLKT-4x4	1.0	BLANKET INSULATION 4' X 4' FOR WATER METERS
RDWD-BRD-2X6X36	2.0	BOARD - REDWOOD 2" X 6" X 36"
IDLR-2.00	1.0	IDLER WATER METER 2" SETTER
BOLTS	4.0	BOLT COPPER #651 SILICONE BRONZE 5/8" X 2-1/2" WITH 2 FLAT WASHERS & NUTS
ERT	1.0	REMOTE TRANSMITTER - SUPPLIED BY CONTRACTOR AND INSTALLED BY TRIGID

SOURCE: TMWA DETAIL 10K-17



DRAWN: \_\_\_\_\_ NT  
 CHECKED: \_\_\_\_\_ CLR  
 REV: \_\_\_\_\_ MAY 2024  
 REV: \_\_\_\_\_

STANDARD DETAIL

**RETROFIT INSTALL - 2" SINGLE SERVICE FOR 2" SETTER, METER, AND TRANSMITTER**

PROCESS

**5.10.8**

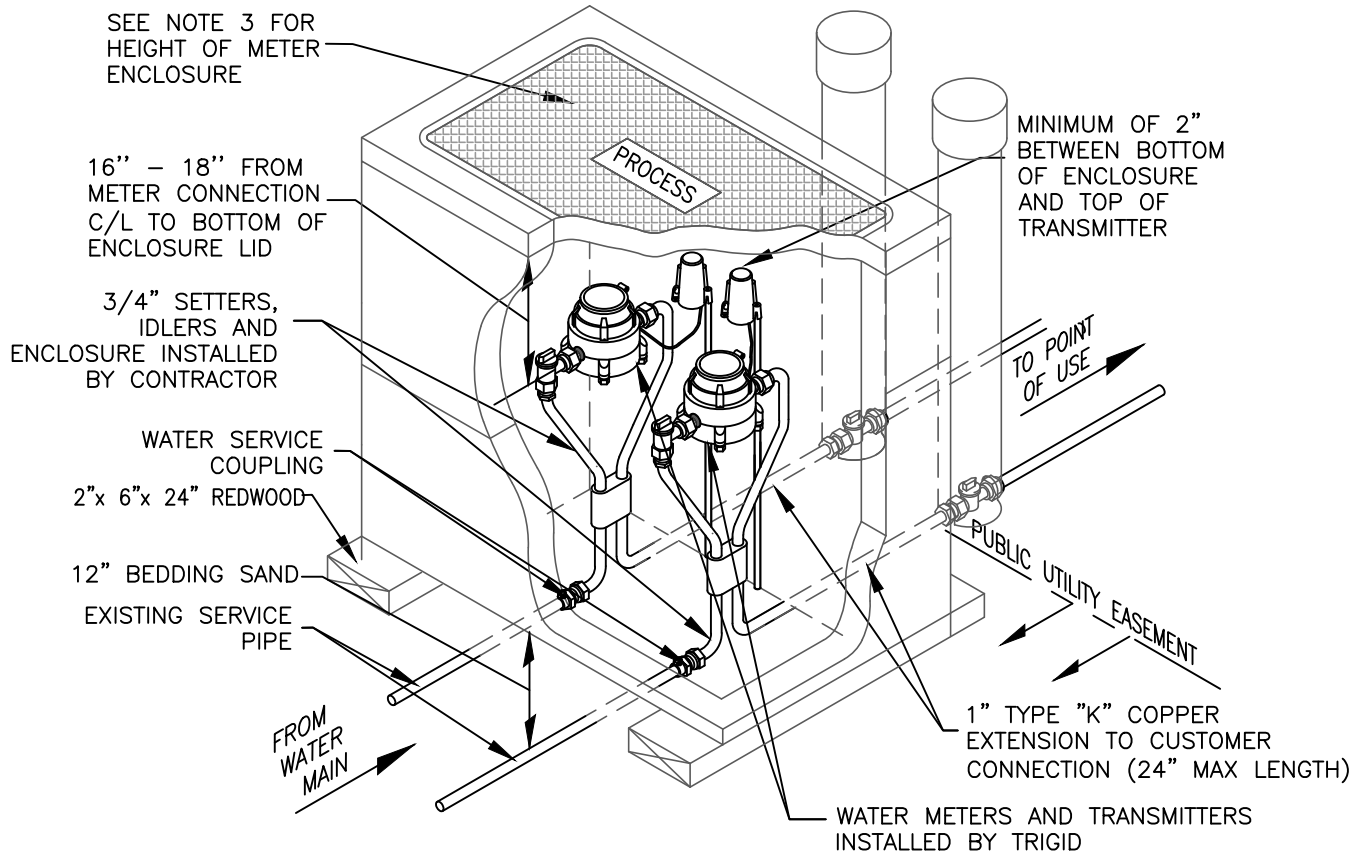

**NOTES:**

1. METER AND TRANSMITTER SUPPLIED BY CONTRACTOR AND INSTALLED BY TRIGID.
2. FOR DRIVEWAY OR TRAFFIC AREAS USE 17X30 ENCLOSURE APPROVED FOR TRAFFIC RATED H/20 LOADING. SEE DETAIL 5.10.11.
3. TOP OF METER ENCLOSURE SHALL BE SET 0.2 FEET ABOVE HIGHEST FINISHED GRADE SURROUNDING ENCLOSURE WITHIN LANDSCAPED AREAS, AND SHALL BE SET FLUSH WITH SURROUNDING FINISH GRADE IN TRAFFIC AREAS.
4. ENCLOSURE TO BE BACKFILLED WITH WATER PIPE BEDDING SAND ONLY, SEE DETAILS 2.17-2.18 BLANKET TO BE INSTALLED ABOVE METER AND BELOW TRANSMITTER.
5. IF SERVICE LINE IS IRON PIPE, GALVANIZED OR BARE STEEL, INSTALL A DIELECTRIC UNION ON THE SETTER. USE A MALE ADAPTER TO CONNECT THE SERVICE LINE. COAT THE ADAPTER AND ONE FOOT OF SERVICE LINE WITH MASTIC.

**MATERIAL LIST**

ITEM ID	QTY.	DESCRIPTION
MS-0.75-RETRO	2.0	SETTER WATER METER
-	2.0	COUPLING SERVICE 1" CTS COMPRESSION X 3/4" FIP
SSL-1.00	2.0	LINER RIGID STAINLESS STEEL FOR 1" CTS HDPE TUBING
GSKT-0.75	4.0	GASKET-3/4" FOR WATER METER
WM-DISC-0.75	2.0	3/4" WATER METER - SUPPLIED AND INSTALLED BY CONTRACTOR
ENCL-17x30-NT	1.0	ENCLOSURE NON-TRAFFIC 17 X 30 WATER METERS, SEE NOTE 2
ENCL-17x30-LID-NT	1.0	COVER NON-TRAFFIC 17 X 30, NON CONCRETE FIBRELYTE LID, SEE NOTE 2
ENCL-17x30-EXT-NT	1.0	EXTENSION BOX NON-TRAFFIC 17 X 30, SEE NOTE 2
INSL-BLKT-4x4	1.0	BLANKET INSULATION 4' X 4' FOR WATER METERS
RDWD-BRD-2x6x24	2.0	BOARD - REDWOOD 2" X 6" X 24"
IDLR-0.75	2.0	IDLER WATER METER 3/4" SETTER
ERT	2.0	REMOTE TRANSMITTER - SUPPLIED BY CONTRACTOR AND INSTALLED BY TRIGID

SOURCE: TMWA DETAIL 10K-16

 TRI-GID 440 USA PKWY, SUITE 105 McCARRAN, NEVADA 89437	DRAWN: _____ NT CHECKED: _____ CLR REV: _____ MAY 2024 REV: _____	STANDARD DETAIL <b>RETROFIT INSTALL - 1" DUAL          SERVICE FOR 3/4" SETTER, METER,          AND TRANSMITTER</b>	PROCESS <b>5.10.9</b>



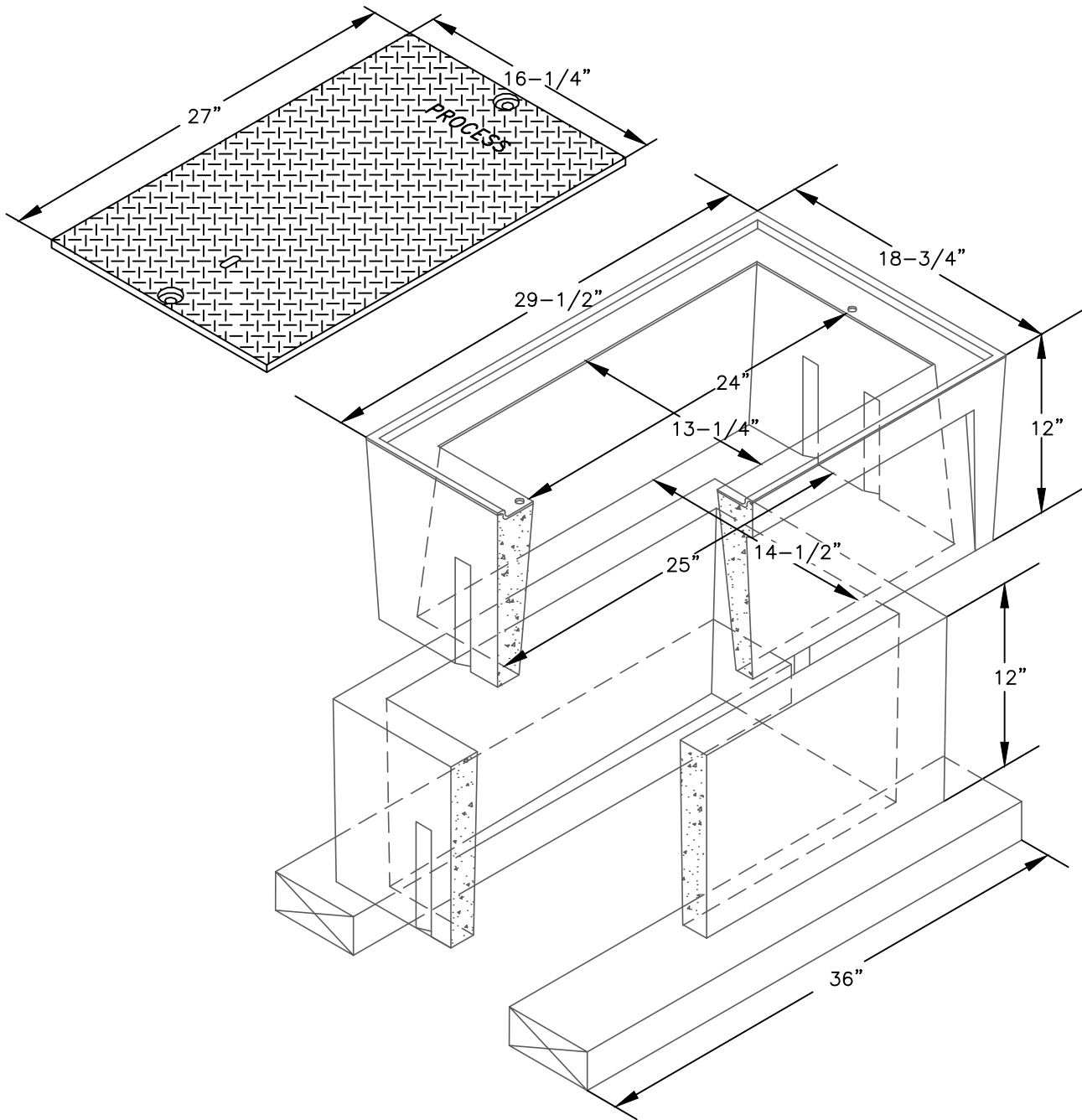

MATERIAL LIST

ITEM ID	QTY.	DESCRIPTION
ENCL-13x24	1.0	ENCLOSURE 13X24 TRAFFIC H/20 RATED
ENCL-13X24-LID	1.0	COVER 13X24 TRAFFIC H/20 RATED - MARKED "PROCESS"
ENCL-13X24-EXT	1.0	EXTENSION BOX 13X24 TRAFFIC H/20 RATED
RDWD-BRD-2X6X36	2.0	BOARD - REDWOOD 2" X 6" X 36"

SOURCE: TMWA DETAIL 10K-17

 <p>440 USA PKWY, SUITE 105 McCARRAN, NEVADA 89437</p>	DRAWN: _____ NT CHECKED: _____ CLR REV: _____ MAY 2024 REV: _____	STANDARD DETAIL	PROCESS
	<p><b>NEW INSTALL - 13"x24"</b> <b>ENCLOSURE - TRAFFIC RATED</b></p>		<p><b>5.10.10</b></p>

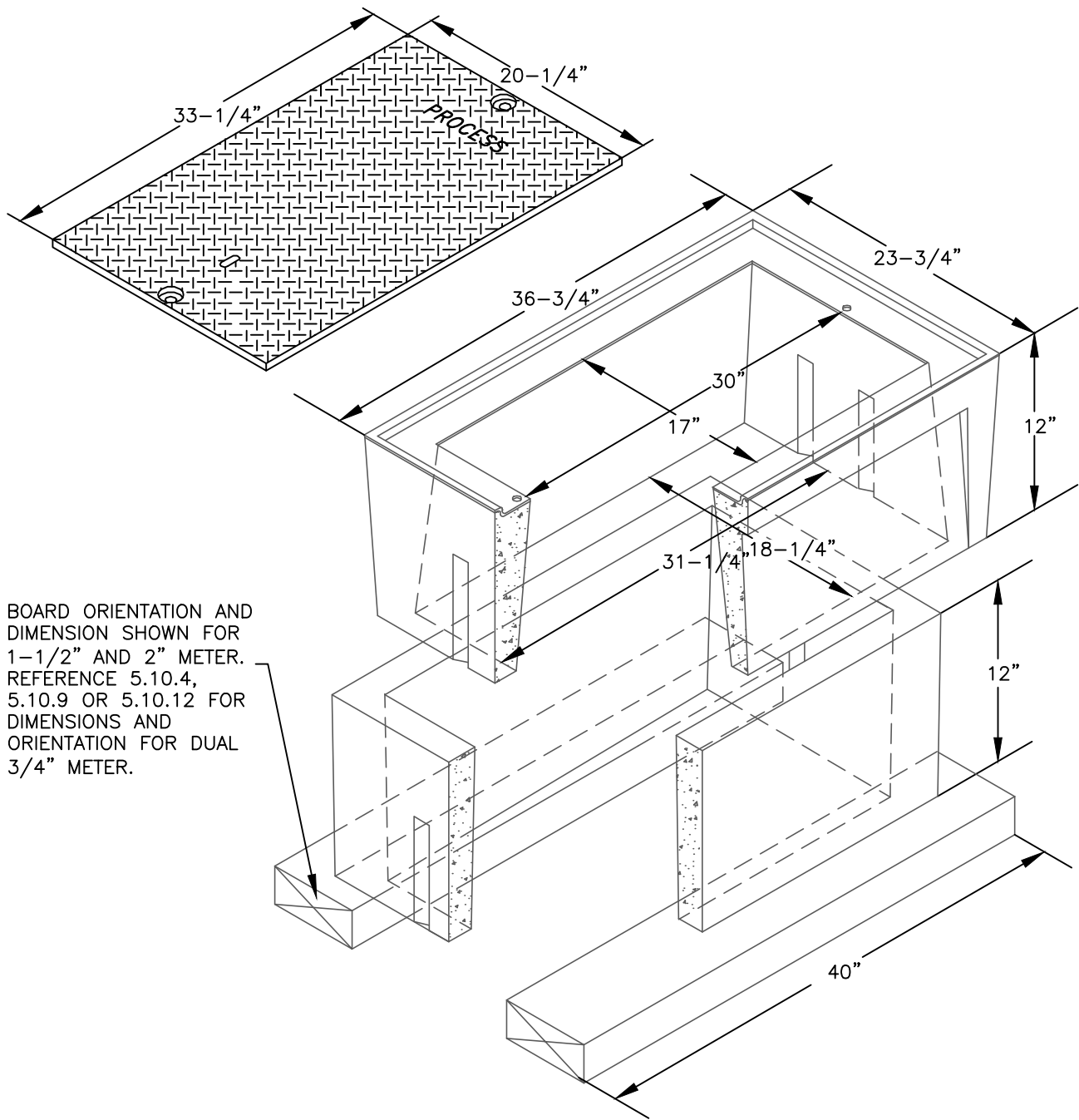

BOARD ORIENTATION AND DIMENSION SHOWN FOR 1-1/2" AND 2" METER. REFERENCE 5.10.4, 5.10.9 OR 5.10.12 FOR DIMENSIONS AND ORIENTATION FOR DUAL 3/4" METER.

MATERIAL LIST

ITEM ID	QTY.	DESCRIPTION
ENCL-17X30	1.0	ENCLOSURE 17X30 TRAFFIC H/20 RATED
ENCL-17X30-LID	1.0	COVER 17X30 TRAFFIC H/20 RATED - MARKED "PROCESS"
ENCL-17X30-EXT	1.0	EXTENSION BOX 17X30 TRAFFIC H/20 RATED
RDWD-BRD-2X6X40	2.0	BOARD - REDWOOD 2" X 6" X 40"

SOURCE: TMWA DETAIL 10K-18



DRAWN: \_\_\_\_\_ NT  
 CHECKED: \_\_\_\_\_ CLR  
 REV: \_\_\_\_\_ MAY 2024  
 REV: \_\_\_\_\_

STANDARD DETAIL  
 NEW INSTALL - 17"x30"  
 ENCLOSURE - TRAFFIC RATED

PROCESS  
 5.10.11

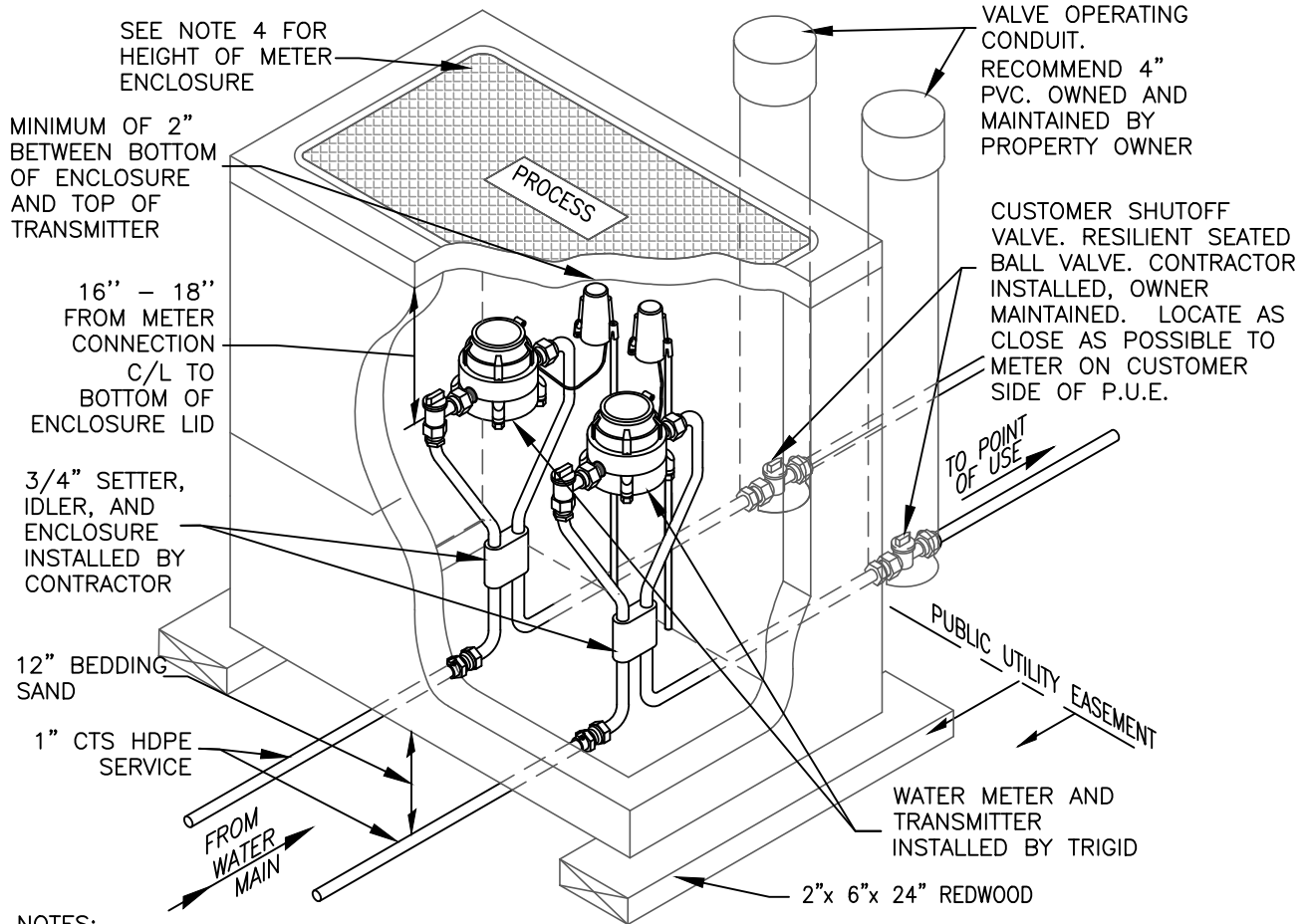

**NOTES:**

1. THERMAL EXPANSION PROTECTION IS REQUIRED IN ANY SUPPLY SYSTEM THAT IS DOWNSTREAM FROM A BACKFLOW PREVENTION DEVICE. REFERENCE: UNIFORM PLUMBING CODE.
2. METER AND TRANSMITTER SUPPLIED BY CONTRACTOR AND INSTALLED BY TRIGID.
3. FOR DRIVEWAY OR TRAFFIC AREAS USE 17X30 ENCLOSURE APPROVED FOR TRAFFIC RATED H/20 LOADING. SEE DETAIL 5.10.11.
4. TOP OF METER ENCLOSURE SHALL BE SET 0.2 FEET ABOVE HIGHEST FINISHED GRADE SURROUNDING ENCLOSURE WITHIN LANDSCAPED AREAS, AND SHALL BE SET FLUSH WITH SURROUNDING FINISH GRADE IN TRAFFIC AREAS.
5. ENCLOSURE TO BE BACKFILLED WITH WATER PIPE BEDDING SAND ONLY, SEE DETAILS 2.17-2.18, TRENCH BEDDING & BACKFILL.
6. BLANKET TO BE INSTALLED ABOVE METER AND BELOW TRANSMITTER.

**MATERIAL LIST**

ITEM ID	QTY.	DESCRIPTION
MS-0.75	2.0	SETTER WATER METER, NEW 3/4" MIP ENDS
WSC-1.00x0.75-CTSxFIP	2.0	COUPLING SERVICE 1" CTS COMPRESSION X 3/4" FIP
SSL-1.00	2.0	LINER RIGID STAINLESS STEEL FOR 1" CTS HDPE TUBING
GSKT-0.75	4.0	GASKET-3/4" FOR WATER METER
WM-DISC-0.75	2.0	3/4" WATER METER - SUPPLIED AND INSTALLED BY CONTRACTOR
ENCL-17x30-NT	1.0	ENCLOSURE NON-TRAFFIC 17 X 30 WATER METERS, SEE NOTE 3
ENCL-17x30-LID-NT	1.0	COVER NON-TRAFFIC 17 X 30, NON CONCRETE FIBRELYTE LID, SEE NOTE 3
ENCL-17x30-EXT-NT	1.0	EXTENSION BOX NON-TRAFFIC 17 X 30, SEE NOTE 3
INSL-BLKT-4x4	1.0	BLANKET INSULATION 4' X 4' FOR WATER METERS
RDWD-BRD-2x6x24	2.0	BOARD - REDWOOD 2" X 6" X 24"
IDLR-0.75	2.0	IDLER WATER METER 3/4" SETTER
ERT	2.0	REMOTE TRANSMITTER - SUPPLIED BY CONTRACTOR AND INSTALLED BY TRIGID

SOURCE: TMWA DETAIL 10K-11

 440 USA PKWY, SUITE 105 McCARRAN, NEVADA 89437	DRAWN: _____ NT CHECKED: _____ CLR REV: _____ MAY 2024 REV: _____	STANDARD DETAIL <b>NEW COMMERCIAL INSTALL - 1"          DUAL SERVICE FOR 3/4" SETTER,          METER, AND TRANSMITTER</b>	PROCESS <b>5.10.12</b>

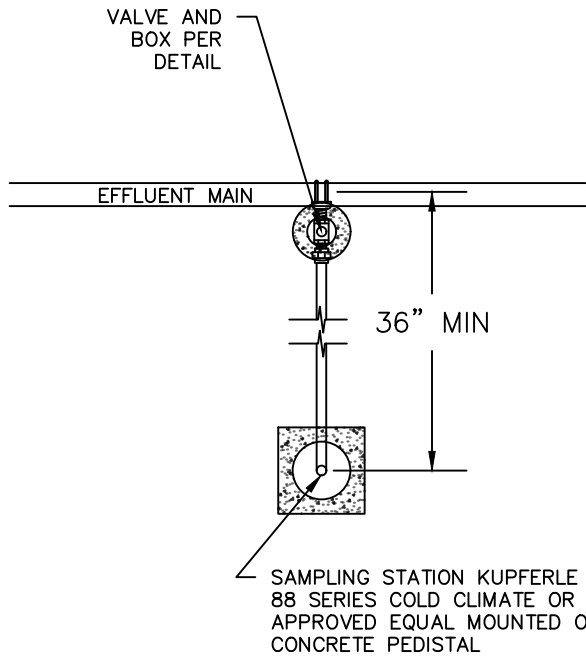

**PLAN VIEW**

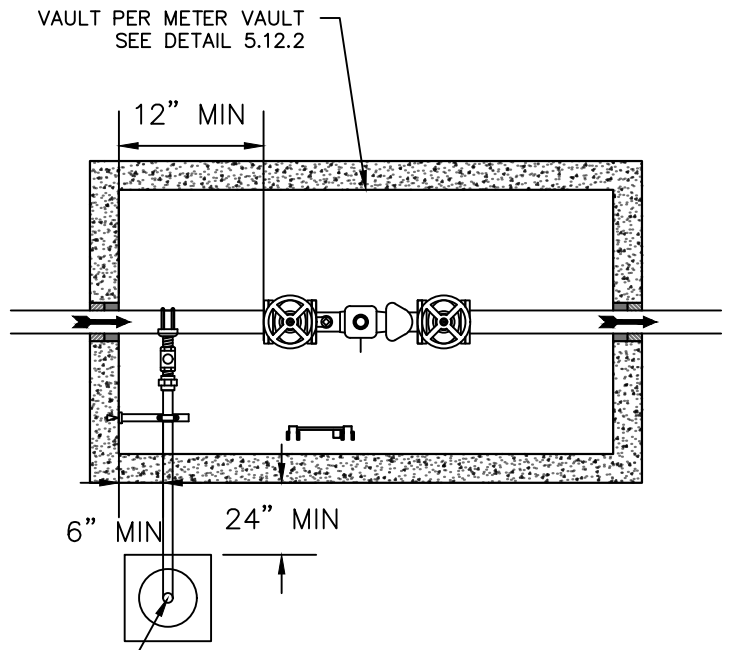

**PLAN VIEW**

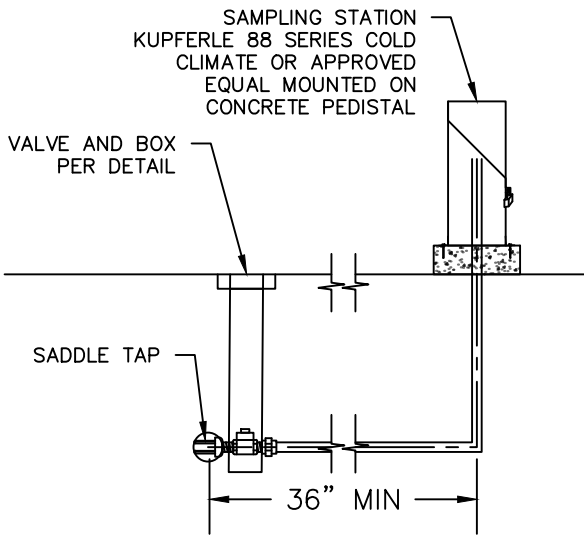

**WITHOUT VAULT**

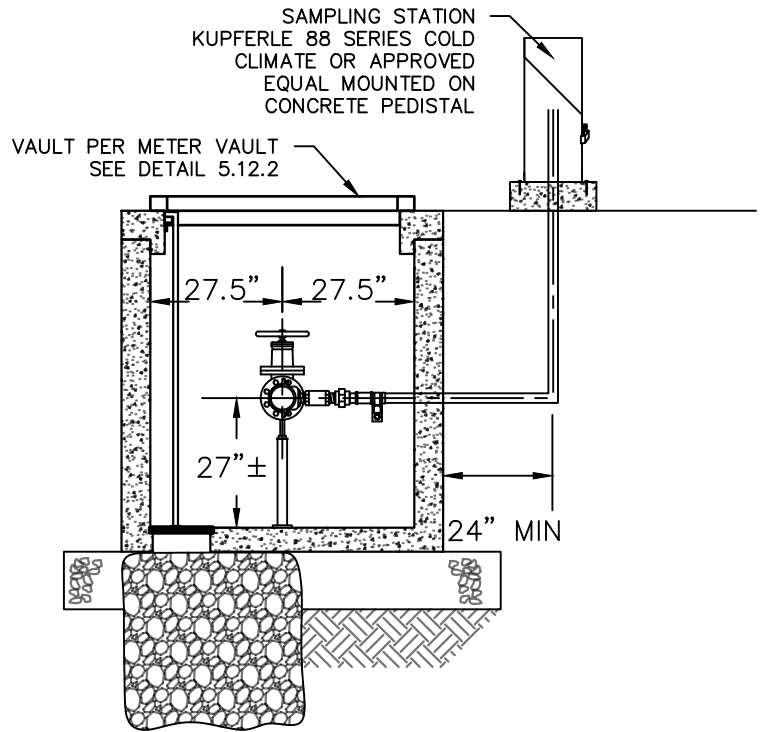

**WITH VAULT**

SOURCE: TMWA DETAIL XX-X



DRAWN: \_\_\_\_\_ NT  
 CHECKED: \_\_\_\_\_ CLR  
 REV: \_\_\_\_\_ MAY 2024  
 REV: \_\_\_\_\_

STANDARD DETAIL

PROCESS

**SAMPLING STATION**

**5.12.1**

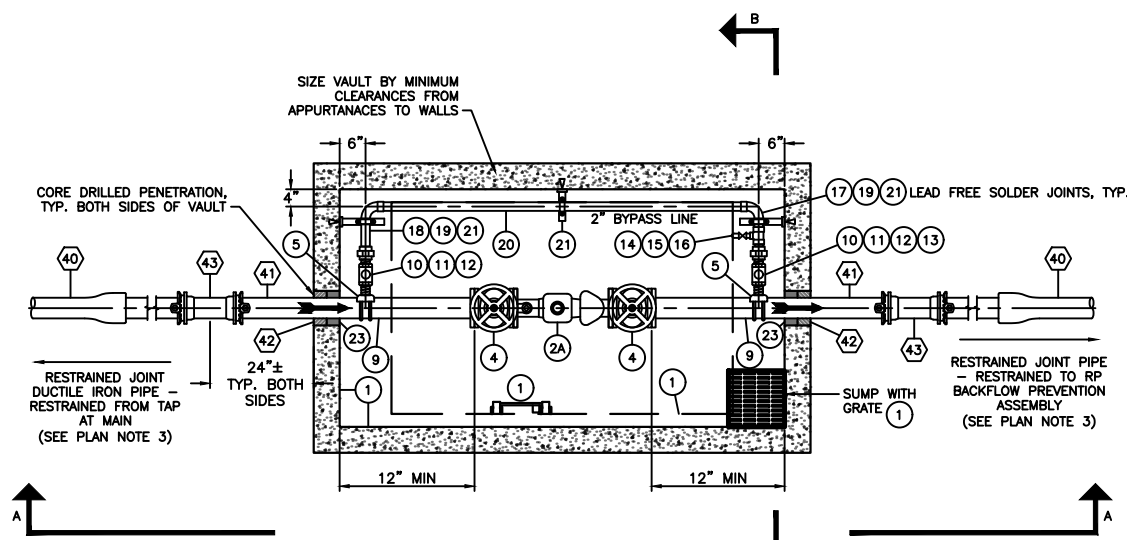

PLAN VIEW

- PLAN NOTES:
- ALL VAULT WALL PENETRATIONS SHALL BE CORE DRILLED IN THE FIELD.
  - METAL COATING FINISH NOTE: APPLICABLE TO ALL METAL SUCH AS STEEL PIPING, BRACKETS, PIPE SUPPORTS, ETC. (EXCLUDING THREADED SURFACES), WHICH HAVE NOT BEEN COATED WITH FUSION BONDED EPOXY. USE TWO-COAT SELF-PRIMING EPOXY SYSTEM CARBOLINE 801. AN ACCEPTABLE ALTERNATIVE COATING SYSTEM IS SHERWIN WILLIAMS EPOXY MASTIC B58 SERIES.
  - ALL RESTRAINED JOINT PIPING SHALL BE DUCTILE IRON PIPE. BELL AND SPIGOT PUSH-ON JOINTS SHALL BE RESTRAINED USING FIELD LOK 350 GASKETS AS MANUFACTURED BY U.S. PIPE OR TRI GID APPROVED EQUIVALENT. RESTRAINED JOINT FITTINGS SHALL BE MECHANICAL JOINT (MJ) DUCTILE IRON WITH MECHANICAL JOINT WEDGE ACTION RESTRAINT GLANDS. MECHANICAL JOINT WEDGE ACTION RESTRAINT GLANDS SHALL BE MEGALUG SERIES 1100 AS MANUFACTURED BY EBAA IRON, INC. OR TRI GID APPROVED EQUIVALENT.
  - FINISH SURFACE TO CONSIST OF 6" TYPE 2, CLASS B CRUSHED AGGREGATE BASE COMPACTED TO 95% MDD EXTENDING MIN. 2 FEET BEYOND VAULT WALLS (UNLESS OTHERWISE SPECIFIED IN THE WATER IMPROVEMENT PLANS). GRADE SLOPE AWAY FROM VAULT AT 2%. FINAL SITE IMPROVEMENTS TO BE APPROVED BY TRI GID INSPECTOR.
  - ALL DUCTILE IRON PIPE AND FITTINGS SHALL BE ENCASED IN POLYETHYLENE ENCASUREMENT CONFORMING TO AWWA C105. ENCASUREMENT SHALL EXTEND AT LEAST TWO FEET BEYOND JOINT AND SHALL BE TAPED SECURELY TO PIPE.
  - METER TO BE SUPPLIED BY CUSTOMER.

- MATERIAL NOTES:
- REFERENCE WATER IMPROVEMENT PLANS FOR CONTINUATION OF MATERIAL REQUIREMENTS OUTSIDE OF VAULT.
  - ALL MATERIALS NOT PER MATERIAL LIST AND SPECIFICATIONS SHALL REQUIRE SUBMITTAL TO ENGINEER FOR APPROVAL PRIOR TO ORDERING.
  - DESIGN ENGINEER SHALL DETERMINE DEPTH TO GROUND WATER. FOR INSTALLATIONS IN AREAS OF HIGH GROUND WATER, DESIGN ENGINEER SHALL COORDINATE VAULT DESIGN MITIGATION WITH JENSEN PRECAST. DO NOT INSTALL DRAIN SUMP.
  - LINE ALL SIDES OF DRAIN SUMP WITH MIRAFI FILTERWEAVE 402 GEOTEXTILE FABRIC PER MANUFACTURER'S APPLICATION TECHNIQUES. BOTTOM OF DRAIN ROCK SHALL BE MINIMUM 2 FEET ABOVE HIGHEST GROUND WATER ELEVATION.

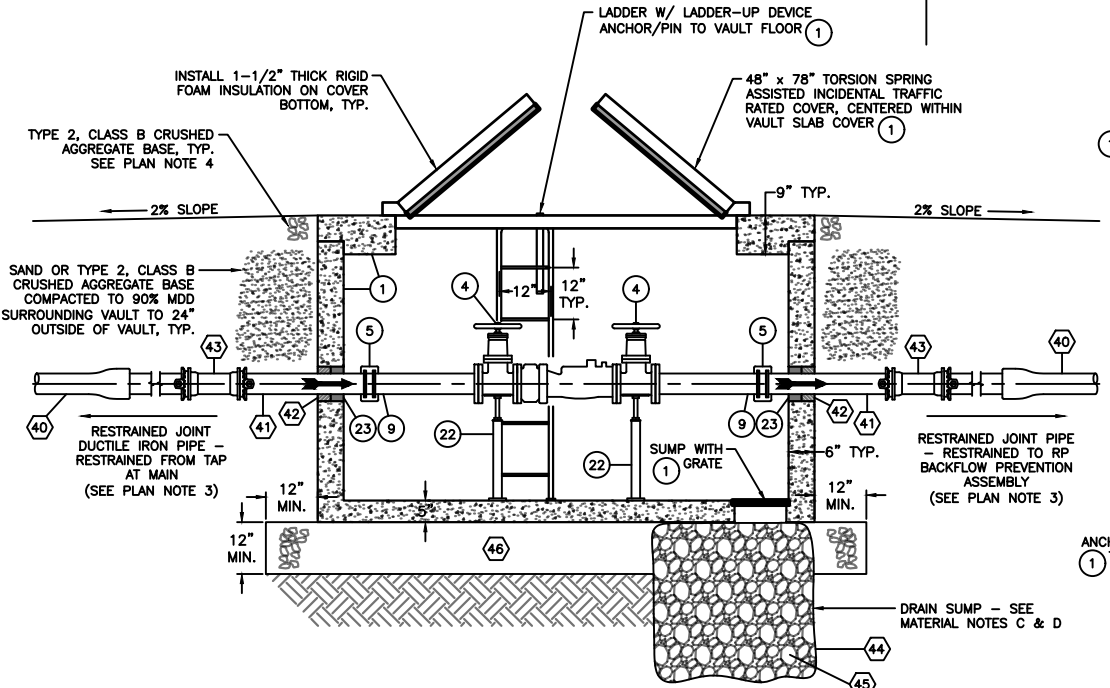
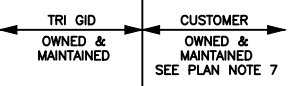

SECTION A - A

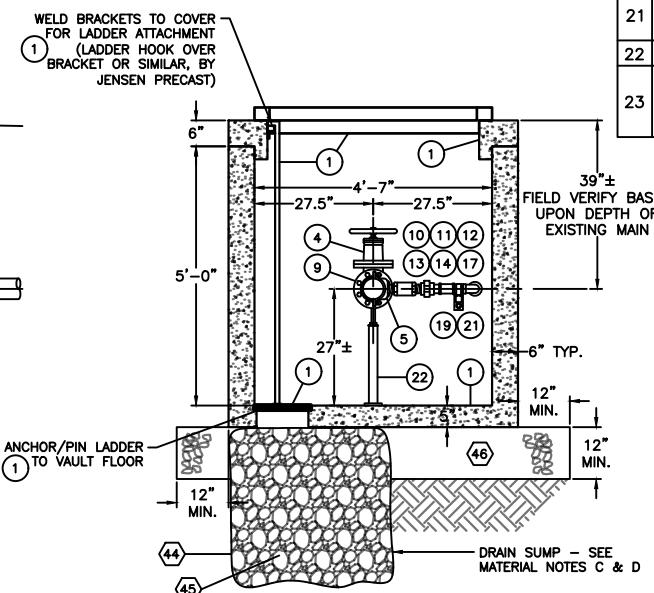

SECTION B - B

MATERIAL LIST

○ INSIDE VAULT

NO.	QTY.	DESCRIPTION
1	1	JENSEN PRECAST INCIDENTAL TRAFFIC LOAD VAULT WITH 12" x 12" SUMP. EXTERIOR VAULT WALLS, BASE, AND SLAB COVER SHALL BE FACTORY WATER SEALED WITH SONNEBORN HLM5000T BY JENSEN PRECAST.
	1	4878/557 GALVANIZED COVER WITH PADLOCK HASP, 48" x 78" TORSION SPRING ASSISTED WITH INCIDENTAL TRAFFIC RATING
	1	12"W x 66"±L REMOVABLE STEEL LADDER WITH LADDER-UP DEVICE. ANCHOR/PIN LADDER TO VAULT FLOOR. TO BE SUPPLIED BY JENSEN PRECAST. FIELD VERIFY LENGTH.
	1	13" x 13" "POLYLOK" GRATE PROVIDED AND INSTALLED BY JENSEN PRECAST
2A	1	METER, OMNI T2 WATER METER WITH FLANGES, (RET) RECORDALL ELECTRONIC TRANSMITTER (NOTE 6) WITH STRAINER
4	2	FLG x FLG RESILIENT WEDGE GATE VALVE W/ HAND WHEEL - MUELLER A-2361 W/ FACTORY FUSION EPOXY COATING, AWWA C-509 W/ NRS
5	2	DI PIPE X 2" NPT, DOUBLE STRAP SERVICE SADDLE, ROMAC 202NS NYLON COATED SADDLE W/ DOUBLE STAINLESS STEEL STRAPS
6	1	FLANGE COUPLING ADAPTER, ROMAC INDUSTRIES FUSION EPOXY STYLE "FCA501"
7	1	SPOOL DUCTILE IRON PIPE, FLG X PE (22" OR 28" IN LENGTH, SEE PLAN NOTE 6)
8	1	SPOOL DUCTILE IRON PIPE, FLG X FLG (10" IN LENGTH)
9	2	FLG X PE DI PIPE - FACTORY CEMENT-MORTAR LINED INTERIOR W/ ASPHALTIC COATING ON EXTERIOR, (38"± IN LENGTH)
10	2	BALL VALVE, BRASS, 2" NPT X NPT, FULL PORT, 600 PSI WOG W/ LOCKABLE S.S. HANDLE NORMALLY CLOSED POSITION (NIBCO T-FP-600N)
11	4	2" NIPPLE, NPT X NPT BRONZE (4"± IN LENGTH)
12	2	2" DIELECTRIC UNION, NPT X SOLDER JOINT (WATTS SERIES 3001A)
13	1	2"Ø NIPPLE TYPE K (HARD) COPPER, SOLDER JOINT X SOLDER JOINT (4"± LONG)
14	1	2" x 2" x 3/4" COPPER TEE, SOLDER JOINT X SOLDER JOINT X SOLDER JOINT
15	1	3/4" FITTING ADAPTER, SOLDER JOINT X FEMALE NPT
16	1	3/4" BRASS QUARTER-TURN HOSE BIB (NIBCO C-26)
17	1	2"Ø TYPE K (HARD) COPPER, SOLDER JOINT X SOLDER JOINT (LENGTH AS REQUIRED)
18	1	2"Ø TYPE K (HARD) COPPER, SOLDER JOINT X SOLDER JOINT (LENGTH AS REQUIRED)
19	2	2"Ø 90° COPPER LONG RADIUS ELBOW, SOLDER JOINT X SOLDER JOINT
20	1	2"Ø TYPE K (HARD) COPPER, SOLDER JOINT X SOLDER JOINT (7'-2"±)
21	3	1-5/8" ROLLED CHANNEL BRACKET W/ 2" CUSHION CLAMP (UNISTRUT NO. P2945 & 038N044). ATTACH TO WALL WITH (2) 1/2"Ø EXPANSION ANCHOR BOLTS
22	2	ADJUSTABLE PIPE SUPPORT
23	2	CALPICO CSL-40-SS ASSEMBLY OF EPDM RUBBER (TOTAL OF 5 LINKS) W/ S.S. BOLTS AND COMPRESSION PLATES FOR 4" DUCTILE IRON PIPE THROUGH AN 8"Ø VAULT BORE HOLE

◇ OUTSIDE VAULT

NO.	QTY.	DESCRIPTION
40	REF.	RESTRAINED JOINT DUCTILE IRON PIPE, BELL WITH FIELD LOK 350 GASKET, ANSI/AWWA C111/A21.11 (U.S. PIPE) - (SEE MATERIAL NOTE A AND PLAN NOTE 3).
41	2	DUCTILE IRON PIPE - SEE NUMBER 9 INSIDE VAULT
42	2	NON-SHRINKING GROUT - FILL ANNULAR SPACE FLUSH WITH VAULT WALL
43	2	MJ x MJ DUCTILE IRON SOLID SLEEVE - LONG (AWWA C110 OR C153) WITH MECHANICAL JOINT WEDGE ACTION RESTRAINT GLANDS - 2 (SEE PLAN NOTE 3)
44	60± SF	MIRAFI FILTERWEAVE 402 GEOTEXTILE FABRIC
45	27 CF	DRAIN ROCK, 3"Ø MINUS FOR SUMP (3' x 3' x 3')
46	90± CF	CRUSHED DRAIN ROCK, 3/4" NOMINAL FOR VAULT BASE. EXTEND BASE ROCK TO 12" BEYOND VAULT FOOTPRINT

NT  
CLR  
MAY 2024  
DRAWN: \_\_\_\_\_  
CHECKED: \_\_\_\_\_  
REV: \_\_\_\_\_



STANDARD DETAIL

METER VAULT AND ASSEMBLY 4" TO 10"

PROCESS

5.12.2



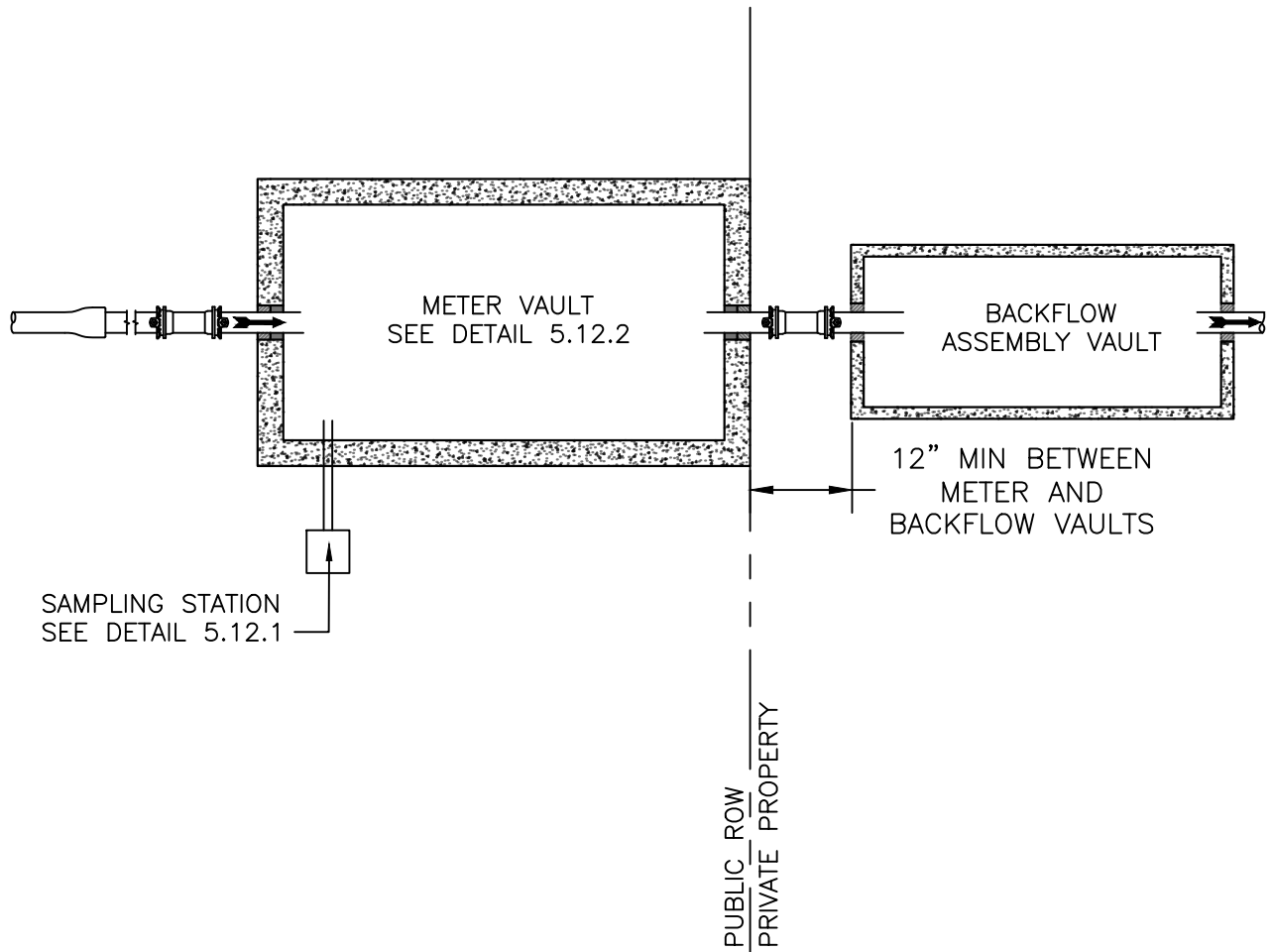

SOURCE: TMWA DETAIL XX-X

 <p>440 USA PKWY, SUITE 105 McCARRAN, NEVADA 89437</p>	DRAWN: _____ NT CHECKED: _____ CLR REV: _____ MAY 2024 REV: _____	STANDARD DETAIL	PROCESS
	<b>BACKFLOW PREVENTION ASSEMBLY 4"-10"</b>		<b>5.12.3</b>

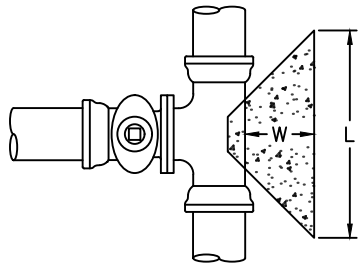

TEE / TAPPING SLEEVE PLAN VIEW

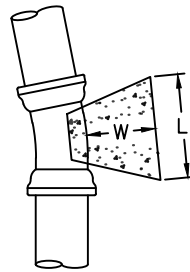

11.25° ELBOW PLAN VIEW

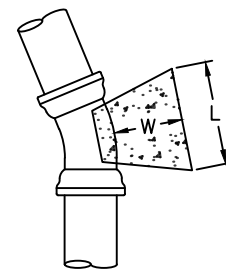

22.5° ELBOW PLAN VIEW

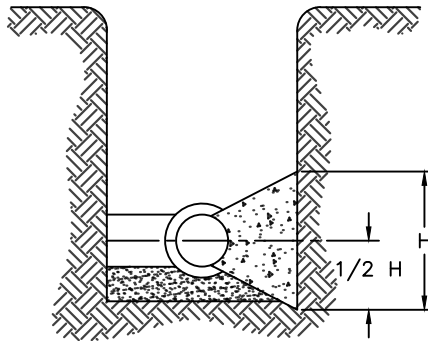

TYPICAL SECTION VIEW

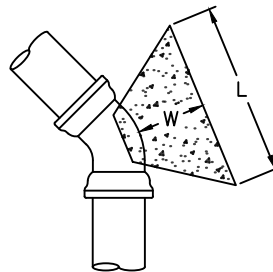

45° ELBOW PLAN VIEW

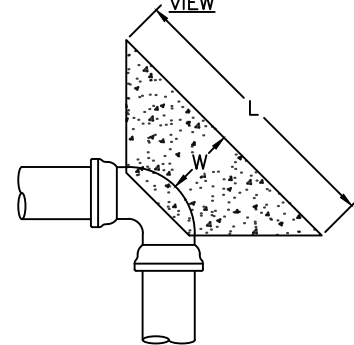

90° ELBOW PLAN VIEW

THRUST BLOCK DIMENSIONS

TEE, TAP, OR DEAD END					11.25° ELBOW			22.5° ELBOW			45° ELBOW			90° ELBOW		
BRANCH SIZE (INCHES)	L (FEET)	H (FEET)	W MIN. (FEET)	ELBOW SIZE (INCHES)	L (FEET)	H (FEET)	W MIN. (FEET)	L (FEET)	H (FEET)	W MIN. (FEET)	L (FEET)	H (FEET)	W MIN. (FEET)	L (FEET)	H (FEET)	W MIN. (FEET)
4	1.5	1	1	4	1	1	1	1	1	1	1.5	1	1	2	1	1
6	2	2	1	6	1	1	1	1.5	1	1	2	1.5	1	2.5	2	1
8	3	2	1	8	1.5	1	1	1.5	1.5	1	2.5	2	1	4	2	1
10	3.5	2.5	1	10	2	1	1	2	2	1	3	2.5	1	5	2.5	1
12	4.5	3	1	12	2	1.5	1	2.5	2	1	4	2.5	1	6	3	1

THRUST BLOCK DESIGN CRITERIA:

THRUST BLOCK SIZES HAVE BEEN CALCULATED USING THE METHOD AND EQUATIONS PUBLISHED IN *THRUST RESTRAINT DESIGN FOR DUCTILE IRON PIPE, SIXTH EDITION 2006* BY THE DUCTILE IRON PIPE RESEARCH ASSOCIATION (DIPRA) UTILIZING THE FOLLOWING DESIGN PARAMETERS:  
 DESIGN PRESSURE = 150 PSI (SEE NOTE #4 BELOW), SOIL BEARING CAPACITY = 2,000 PSF (SEE NOTE #4 BELOW), SAFETY FACTOR = 1.5, AND NOMINAL PIPE DIAMETER

THRUST BLOCK NOTES:

1. CONCRETE FOR THRUST BLOCKS SHALL HAVE A MINIMUM 28-DAY COMPRESSIVE STRENGTH OF 3,000 PSI. ALL FITTINGS SHALL BE WRAPPED WITH POLYETHYLENE WRAP PER AWWA C105. MASTIC (BRUSH-ON) SHALL BE APPLIED TO ALL BOLTS, ETC.
2. THRUST BLOCKS SHALL BE POURED AGAINST UNDISTURBED SOIL. IN CASES WHERE THIS IS NOT PRACTICAL, BACKFILL AREA BEHIND WHERE THRUST BLOCK WILL BE POURED WITH TYPE 2, CLASS B AGGREGATE BASE (PER SECTION 200.01.03 OF THE STANDARD SPECIFICATIONS FOR PUBLIC WORKS CONSTRUCTION - ORANGE BOOK) COMPACTED TO 95% MAXIMUM DRY DENSITY AT OPTIMUM MOISTURE CONTENT AS DETERMINED BY PROCEDURES SET FORTH IN ASTM D 1557, CUT-BACK COMPACTED AGGREGATE BASE TO EXPOSE A FIRM SURFACE, THEN POUR THRUST BLOCK.
3. FOR SOIL BEARING CAPACITY LESS THAN 2,000 PSF AND/OR DESIGN PRESSURE IN EXCESS OF 150 PSI, INCREASE THRUST BLOCK BEARING AREAS ACCORDINGLY. REVISED THRUST BLOCK SCHEDULE FOR SPECIFIC CONDITIONS SHALL BE SUBMITTED BY THE DESIGN ENGINEER.

SOURCE: TMWA DETAIL 10L-2



DRAWN: \_\_\_\_\_ NT  
 CHECKED: \_\_\_\_\_ CLR  
 REV: \_\_\_\_\_ MAY 2024  
 REV: \_\_\_\_\_

STANDARD DETAIL  
**THRUST AND ANCHOR  
 BLOCKS**

PROCESS  
**5.13.1**



PLACER WATERWORKS,  
INC CATALOG  
#AE3618MT FOR  
LID AND RISER TUBE

6"Ø SDR 35 PIPE WITH G5  
VALVE BOX WITH COVER MARKED  
"PROCESS". LOCATED OUT OF TRAFFIC  
AREA.

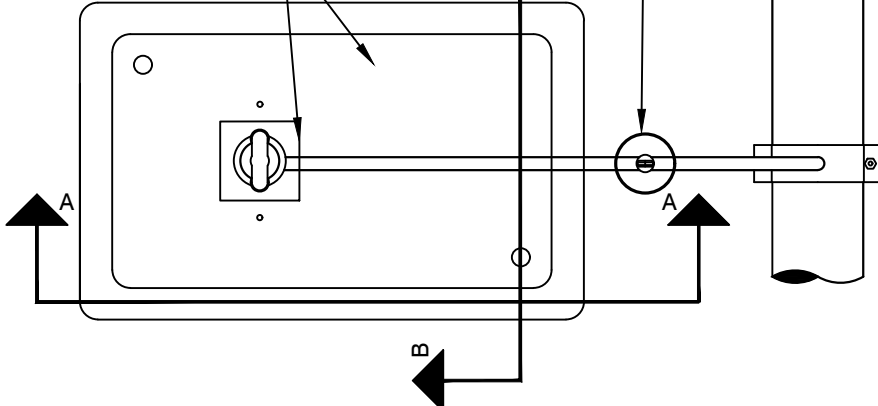

**PLAN VIEW**

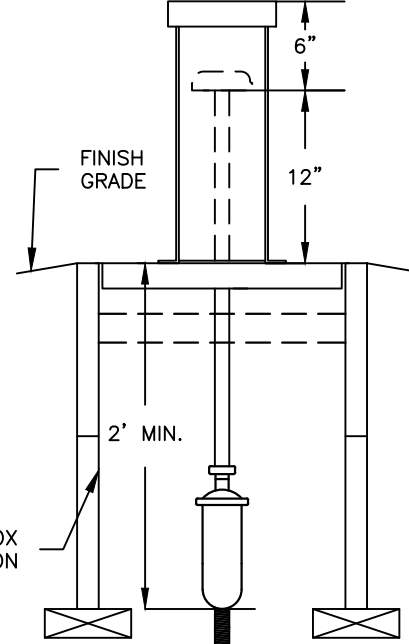

**SECTION B-B**

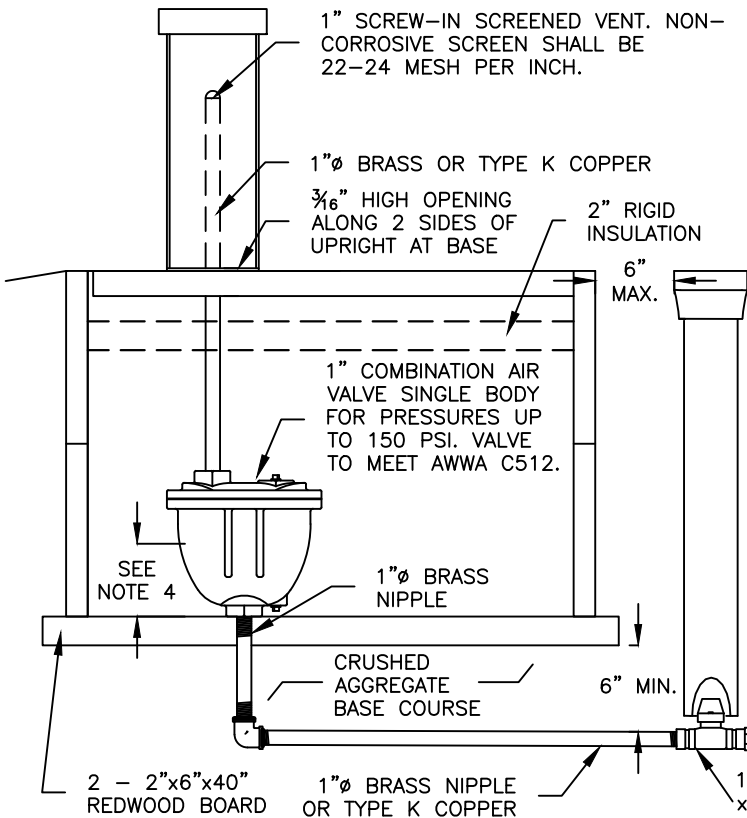

**SECTION A-A**

**NOTES**

1. REFER TO DETAIL 2.8.1 FOR SERVICE TAP INSTALLATION.
2. REFER TO 5.16 FOR TRENCH BEDDING AROUND HDPE PORTION OF THIS DETAIL. BEDDING SAND TO BE USED UNLESS OTHERWISE CALLED FOR.
3. TOP OF ENCLOSURE AND VALVE CAP SHALL BE SET 0.2 FEET ABOVE HIGHEST FINISHED GRADE SURROUNDING ENCLOSURE WITH LANDSCAPE AREAS.
4. PLACE TYPE 2 CLASS B CRUSHED AGGREGATE BASE WITHIN BOX TO EXTEND HALF WAY UP BODY OF THE ARV AND EXTEND UNDER BOX TO A DEPTH OF 6" BELOW THE BRASS NIPPLE/COPPER TUBE. BASE TO EXTEND FROM THE ARV TO THE CURB VALVE AND BEYOND THE EXTENTS OF THE ENCLOSURE FOR 6-INCHES.

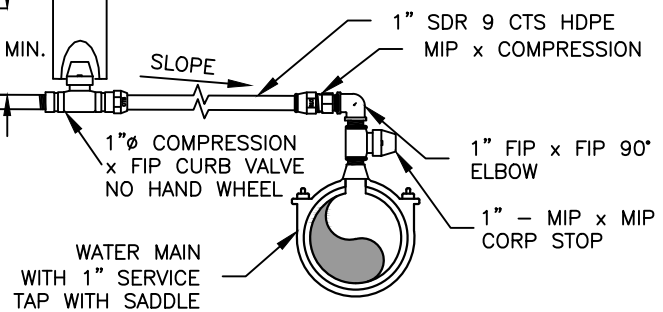

SOURCE: TMWA DETAIL 10L-4



DRAWN: \_\_\_\_\_ NT  
 CHECKED: \_\_\_\_\_ CLR  
 REV: \_\_\_\_\_ MAY 2024  
 REV: \_\_\_\_\_

STANDARD DETAIL

# AIR RELEASE VALVE ASSEMBLY

PROCESS

## 5.14.1

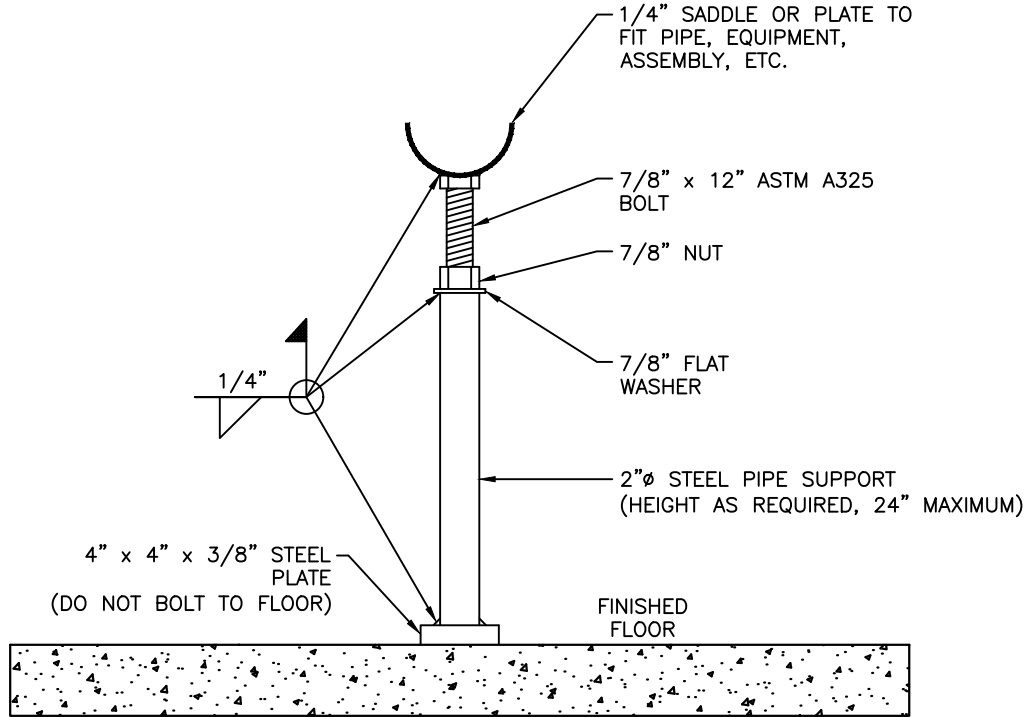

METAL COATING FINISH NOTE:

1. ALL NON-THREADED COMPONENTS, WHICH HAVE NOT BEEN COATED WITH FUSION BONDED EPOXY, SHALL BE COATED USING TWO-COAT SELF-PRIMING EPOXY SYSTEM CARBOLINE 801. AN ACCEPTABLE ALTERNATIVE COATING SYSTEM IS SHERWIN WILLIAMS EPOXY MASTIC B58 SERIES.
2. ALL METAL SURFACES TO BE COATED SHALL RECEIVE SURFACE PREPARATION EQUIVALENT TO POWER TOOL CLEANING (SSPC-SP3) BY POWER WIRE BRUSHING, POWER IMPACT TOOLS, OR POWER SANDERS, OR EQUIVALENT TO BRUSH-OFF BLAST CLEANING (SSPC-SP7) TO REMOVE RUST, MILL SCALE, AND OTHER DETRIMENTAL FOREIGN MATERIALS PRESENT UNTIL AT LEAST TWO-THIRDS OF EACH ELEMENT OF SURFACE AREA IS FREE OF ALL VISIBLE RESIDUE. APPLICATION OF THE EPOXY COATING SYSTEM SHALL FOLLOW IMMEDIATELY AFTER SURFACE PREPARATION. ANY CLEANED AREAS NOT COATED BEFORE CORROSION FORMS SHALL BE RE-CLEANED PRIOR TO THE APPLICATION OF THE EPOXY COATING.

SOURCE: TMWA DETAIL 10L-5



DRAWN: \_\_\_\_\_ NT  
CHECKED: \_\_\_\_\_ CLR  
REV: \_\_\_\_\_ MAY 2024  
REV: \_\_\_\_\_

STANDARD DETAIL

**ADJUSTABLE PIPE  
SUPPORT**

PROCESS

5.15.1

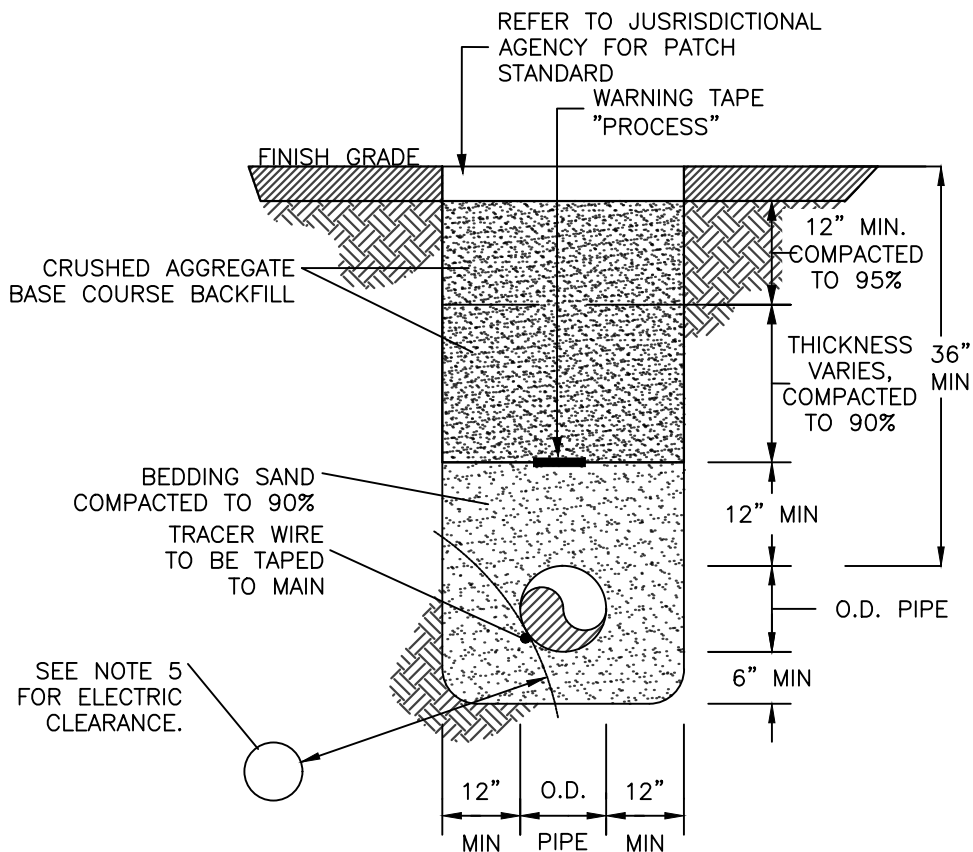

NOTES:

1. ALL TRENCHES MUST CONFORM TO APPLICABLE TRIGID, STATE, COUNTY, AND OSHA SPECIFICATIONS AND REQUIREMENTS. IN THE CASE OF CONFLICT, THE MORE RIGID SPECIFICATION OR STANDARD SHALL APPLY.
2. BEDDING SAND SHALL CONFORM WITH ORANGE BOOK CLASS A REQUIREMENTS, COMPACTED TO 90% MAXIMUM DENSITY, AND SHALL BE A MINIMUM OF 12" ABOVE AND 6" BELOW THE MAIN.
3. CRUSHED AGGREGATE BASE COURSE BACKFILL SHALL CONFORM TO ORANGE BOOK CLASS 2 TYPE B REQUIREMENTS AND BE PLACED IN 12" MAXIMUM LOOSE LIFTS. THE TOP 12" SHALL BE COMPACTED TO 95% MAXIMUM DENSITY. THE AREA ABOVE THE BEDDING SAND & BELOW 12" FROM FINISH GRADE SHALL BE COMPACTED TO 90% MAXIMUM DENSITY.
4. NON-METALLIC BLUE WARNING TAPE SHALL BE PLACED IN ALL TRENCHES AT LEAST 12" ABOVE THE WATER MAIN.
5. ELECTRIC UTILITIES MUST BE LOCATED BELOW WATER & MAINTAIN 2' MINIMUM RADIAL CLEARANCE FROM TRIGID WATER FACILITIES. IF 2' RADIAL CLEARANCE CAN NOT BE MET ELECTRIC CONDUIT MUST BE CONCRETE ENCASED AT LEAST 18" EACH SIDE OF WATER CROSSING. FIBER OPTIC AND/OR COMMUNICATION CONDUITS SHALL NOT BE PLACE IN THE SAME TRENCH AS WATER.
6. ALL CHANGES MUST BE APPROVED BY THE TRIGID INSPECTOR AND/OR THE TRIGID ENGINEER.
7. SEPARATION FOR PIPES IN A JOINT TRENCH SHALL BE A MINIMUM OF 12".
8. TRACER WIRE SHALL BE #14 COPPER CLAD STAINLESS STEEL CORE WITH 30 MILS BLUE HDPE INSULATION. ALL WIRE SPLICES SHALL BE MADE USING A SPLIT BOLT CONNECTOR WRAPPED WITH AQUASEAL AND ELECTRIC TAPE. THE CONTRACTOR SHALL INSTALL A 3 POUND ANODE AT EVERY TEST STATION. TEST STATIONS SHALL BE LOCATED ALONG THE MAIN NO MORE THAN 500 FEET APART. REFER TO SUBSECTION 2.21.2.

SOURCE: TMWA DETAIL 10L-6



DRAWN: \_\_\_\_\_ NT  
 CHECKED: \_\_\_\_\_ CLR  
 REV: \_\_\_\_\_ MAY 2024  
 REV: \_\_\_\_\_

STANDARD DETAIL

**TRENCH DETAIL -  
 PROCESS WATER ONLY**

PROCESS

**5.16.1**

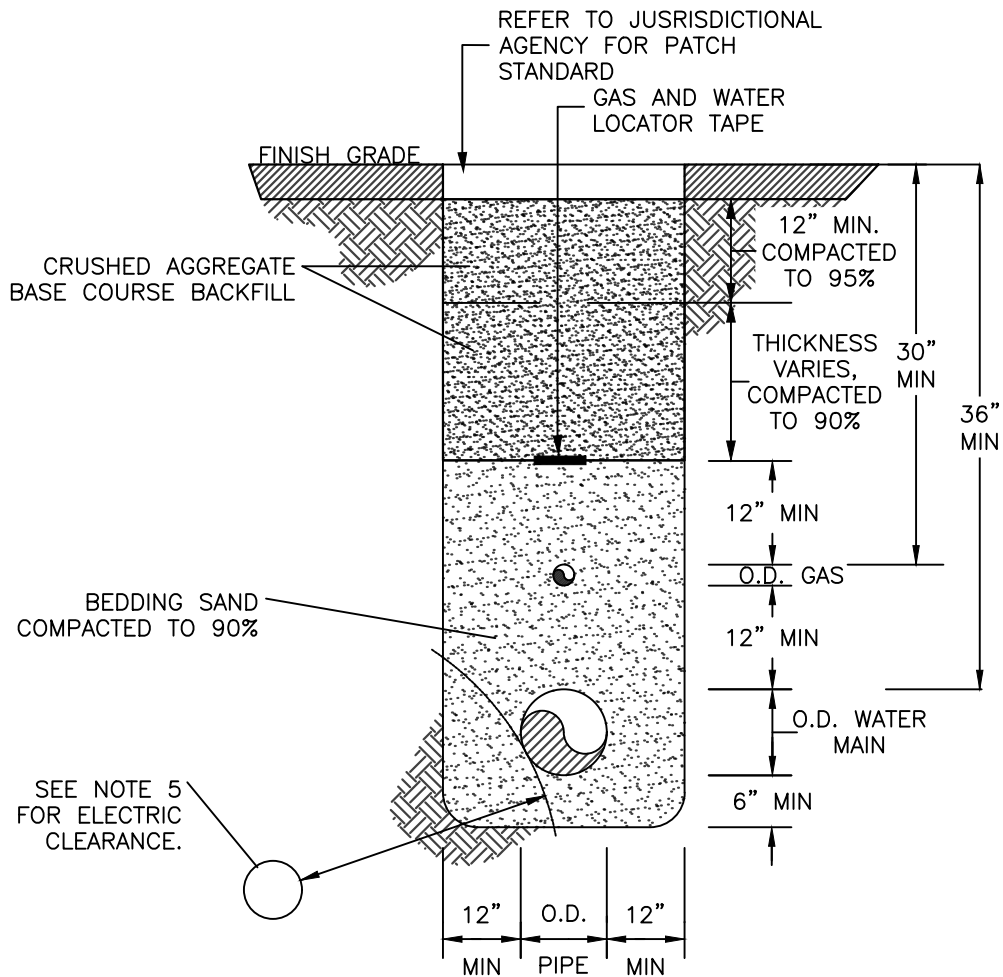

NOTES:

1. ALL TRENCHES MUST CONFORM TO APPLICABLE TRIGID, STATE, COUNTY, AND OSHA SPECIFICATIONS AND REQUIREMENTS. IN THE CASE OF CONFLICT, THE MORE RIGID SPECIFICATION OR STANDARD SHALL APPLY.
2. BEDDING SAND SHALL CONFORM WITH ORANGE BOOK CLASS A REQUIREMENTS, COMPACTED TO 90% MAXIMUM DENSITY, AND SHALL BE A MINIMUM OF 12" ABOVE AND 6" BELOW THE MAIN.
3. CRUSHED AGGREGATE BASE COURSE BACKFILL SHALL CONFORM TO ORANGE BOOK CLASS 2 TYPE B REQUIREMENTS AND BE PLACED IN 12" MAXIMUM LOOSE LIFTS. THE TOP 12" SHALL BE COMPACTED TO 95% MAXIMUM DENSITY. THE AREA ABOVE THE BEDDING SAND & BELOW 12" FROM FINISH GRADE SHALL BE COMPACTED TO 90% MAXIMUM DENSITY.
4. METALLIC WATER AND GAS LOCATOR TAPE SHALL BE PLACED IN ALL TRENCHES AT LEAST 12" ABOVE THE GAS.
5. ELECTRIC UTILITIES MUST BE LOCATED BELOW WATER & MAINTAIN 2' MINIMUM RADIAL CLEARANCE FROM TRIGID WATER FACILITIES. IF 2' RADIAL CLEARANCE CAN NOT BE MET ELECTRIC CONDUIT MUST BE CONCRETE ENCASED AT LEAST 18" EACH SIDE OF WATER CROSSING. FIBER OPTIC AND/OR COMMUNICATION CONDUITS SHALL NOT BE PLACED IN THE SAME TRENCH AS WATER.
6. ALL CHANGES MUST BE APPROVED BY THE TRIGID INSPECTOR AND/OR THE TRIGID ENGINEER.
7. SEPARATION FOR PIPES IN A JOINT TRENCH SHALL BE A MINIMUM OF 12".

SOURCE: TMWA DETAIL 10L-7



DRAWN: \_\_\_\_\_ NT  
 CHECKED: \_\_\_\_\_ CLR  
 REV: \_\_\_\_\_ MAY 2024  
 REV: \_\_\_\_\_

STANDARD DETAIL

TRENCH DETAIL - GAS  
 AND PROCESS WATER

PROCESS

5.17.1

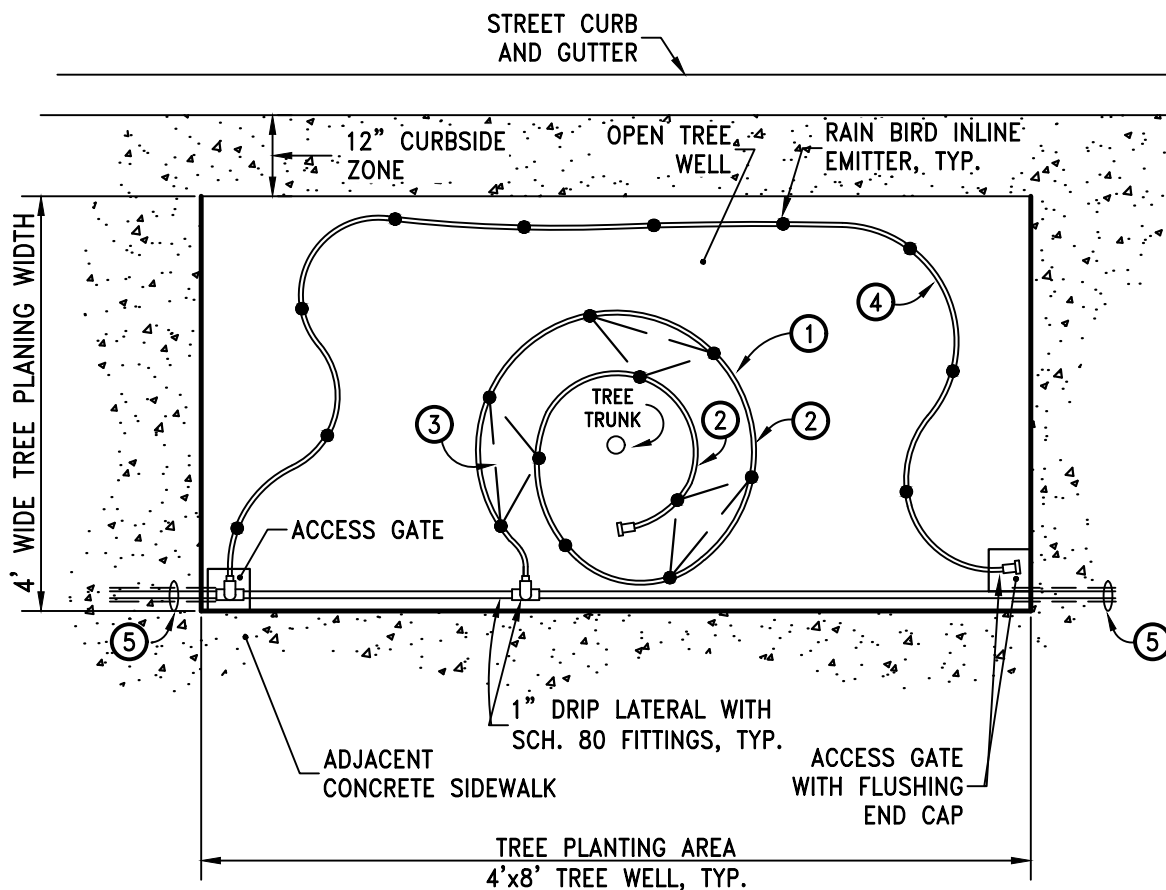

### PLAN

#### NOTES:

- ① RAIN BIRD XF SERIES (XFD-09-24) DRIPLINE WITH (10) EMITTERS PER TREE AT 0.90 GPH = 9.0 GPH PER TREE WITH FLUSHING END CAP (MDCFAP)
- ② PLACE FIRST RING 12" FROM TREE TRUNK AND PLACE SECOND RING 28" FROM THE TREE TRUNK.
- ③ LAYOUT DRIPLINE TO CREATE TRIANGULAR SPACING PATTERN WITH INLINE EMITTERS, TYP.
- ④ FUTURE TREE MATURITY IRRIGATION. RAIN BIRD INLINE EMITTER WITH (10) 0.92 GPH INLINE EMITTERS AT 24" SPACING. ACTIVATE FOR FUTURE USE.
- ⑤ PROVIDE 2" MIN. SCH. 40 PVC SLEEVE WITH 1" MIN. SALCO LATERAL RUNNING BETWEEN OPEN TREE WELLS AT 18" MIN. DEPTH.

SOURCE: CITY OF RENO DETAIL R-520A



DRAWN: \_\_\_\_\_ NT  
CHECKED: \_\_\_\_\_ CLR  
REV: \_\_\_\_\_ MAY 2024  
REV: \_\_\_\_\_

STANDARD DETAIL

LANDSCAPE

TREE WELL DRIP  
IRRIGATION

6.1A.1

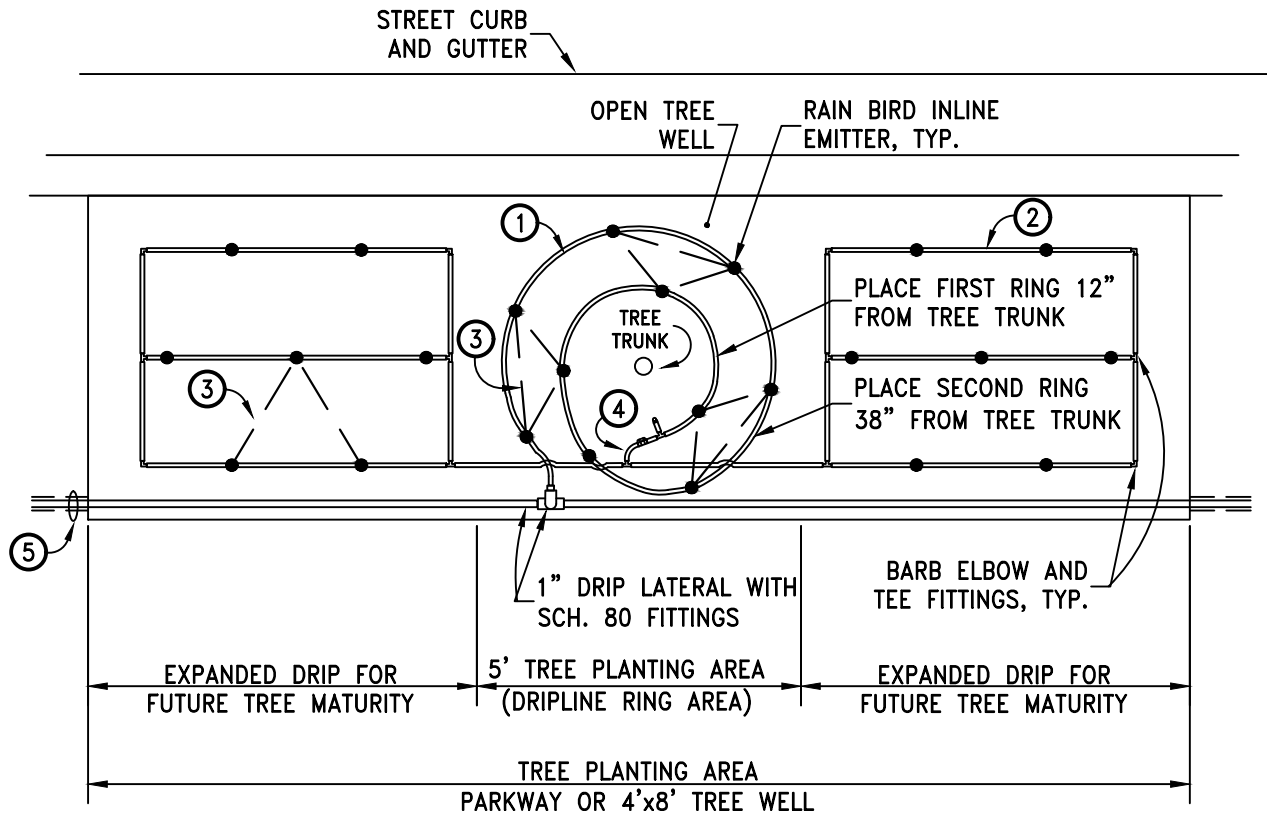

**PLAN**

**NOTES:**

- ① RAIN BIRD XF SERIES (XFD-09-24) DRIPLINE WITH 10 EMITTERS PER TREE AT 0.90 GPH = 9.0 GPH PER TREE WITH FLUSHING END CAP (MDCF-CAP)
- ② EXPANDED XF SERIES DRIPLINE (XFD-09-24) FOR FUTURE TREE MATURITY IRRIGATION.
- ③ LAYOUT DRIPLINE TO CREATE TRIANGULAR SPACING PATTERN WITH INLINE EMITTERS, TYP.
- ④ EXPANSION DRIPLINE WITH BALL VALVE CONNECTED TO DRIPLINE RING FOR FUTURE/TREE MATURITY IRRIGATION, SEE DETAIL A BELOW.
- ⑤ PROVIDE 2" MIN. SCH. 40 PVC SLEEVE WITH 1" MIN. SALCO LATERAL RUNNING BETWEEN OPEN TREE PITS AT 18" MIN. DEPTH.
- ⑥ 1/2" (THREAD BY THREAD) PVC BALL VALVE WITH RAINBIRD XFF-MA-050 INSERT BY 1/2" MAIL MPT ADAPTOR FITTINGS

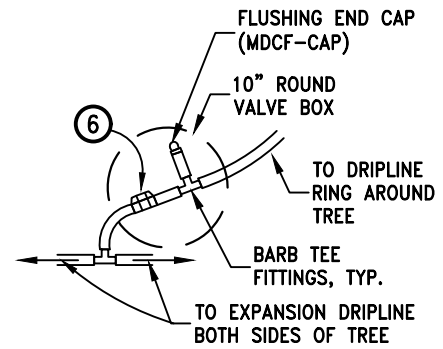

**DETAIL A**

SOURCE: CITY OF RENO DETAIL R-520B



DRAWN: \_\_\_\_\_ NT  
 CHECKED: \_\_\_\_\_ CLR  
 REV: \_\_\_\_\_ MAY 2024  
 REV: \_\_\_\_\_

STANDARD DETAIL

LANDSCAPE

**PARKWAY DRIP IRRIGATION**

6.1B.1

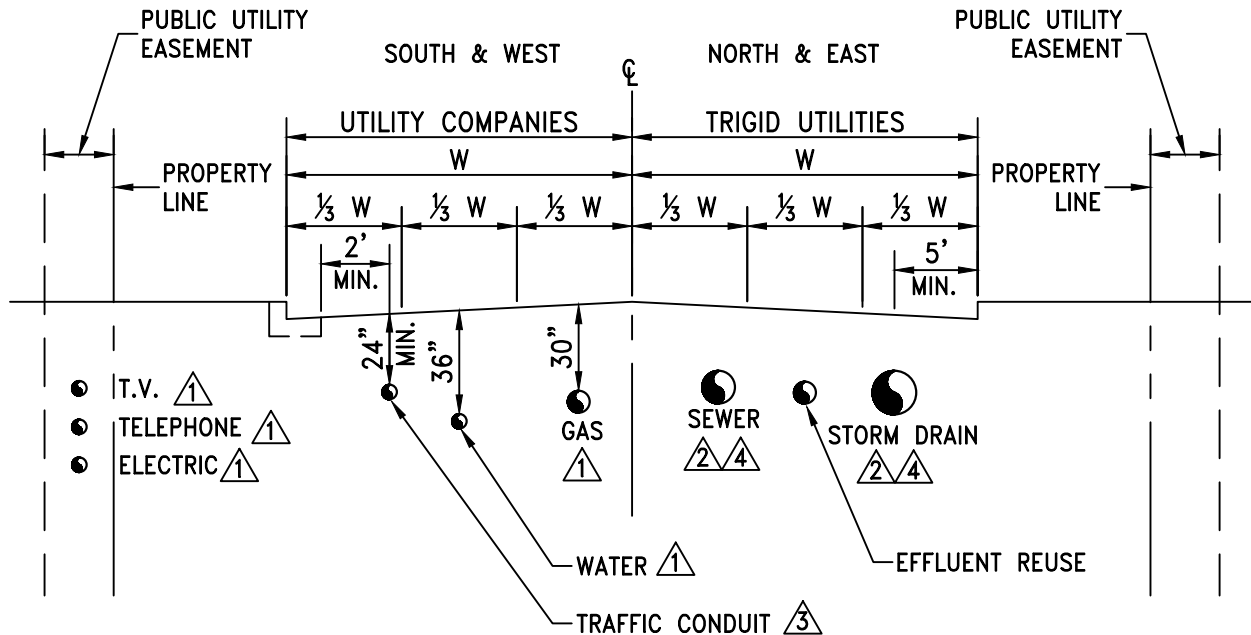

**ABBREVIATIONS:**

W = WIDTH FROM CENTERLINE (℄) OF ROADWAY TO FRONT FACE OF CURB.

**NOTES:**

- ① SEE OWNING UTILITY COMPANY FOR STANDARD TRENCH SECTIONS.
- ② SEE STANDARD DETAIL DETAIL 2.17 AND 5.16 FOR TYPICAL SANITARY SEWER, WATER, AND PROCESS WATER SECTION.
- ③ TRAFFIC CONDUITS ARE ALLOWED TO BE PLACED ON EITHER SIDE OF THE ROADWAY PER THE DIMENSION LIMITATIONS SHOWN.
- ④ MINIMUM DISTANCE FROM CENTERLINES OF EITHER STORM DRAIN OR SEWER LINES TO THE FACE OF CURB IS 5 FEET.
- ⑤ IF APPLICABLE, PRIORITIZE STOREY COUNTY SPECIFICATIONS.

SOURCE: CITY OF RENO DETAIL R-103

 <p>440 USA PKWY, SUITE 105 McCARRAN, NEVADA 89437</p>	DRAWN: _____ NT CHECKED: _____ CLR REV: _____ MAY 2024 REV: _____	STANDARD DETAIL	MISC.
	<h1>TYPICAL UTILITY MAIN LOCATIONS</h1>		<h2>7.1.1</h2>



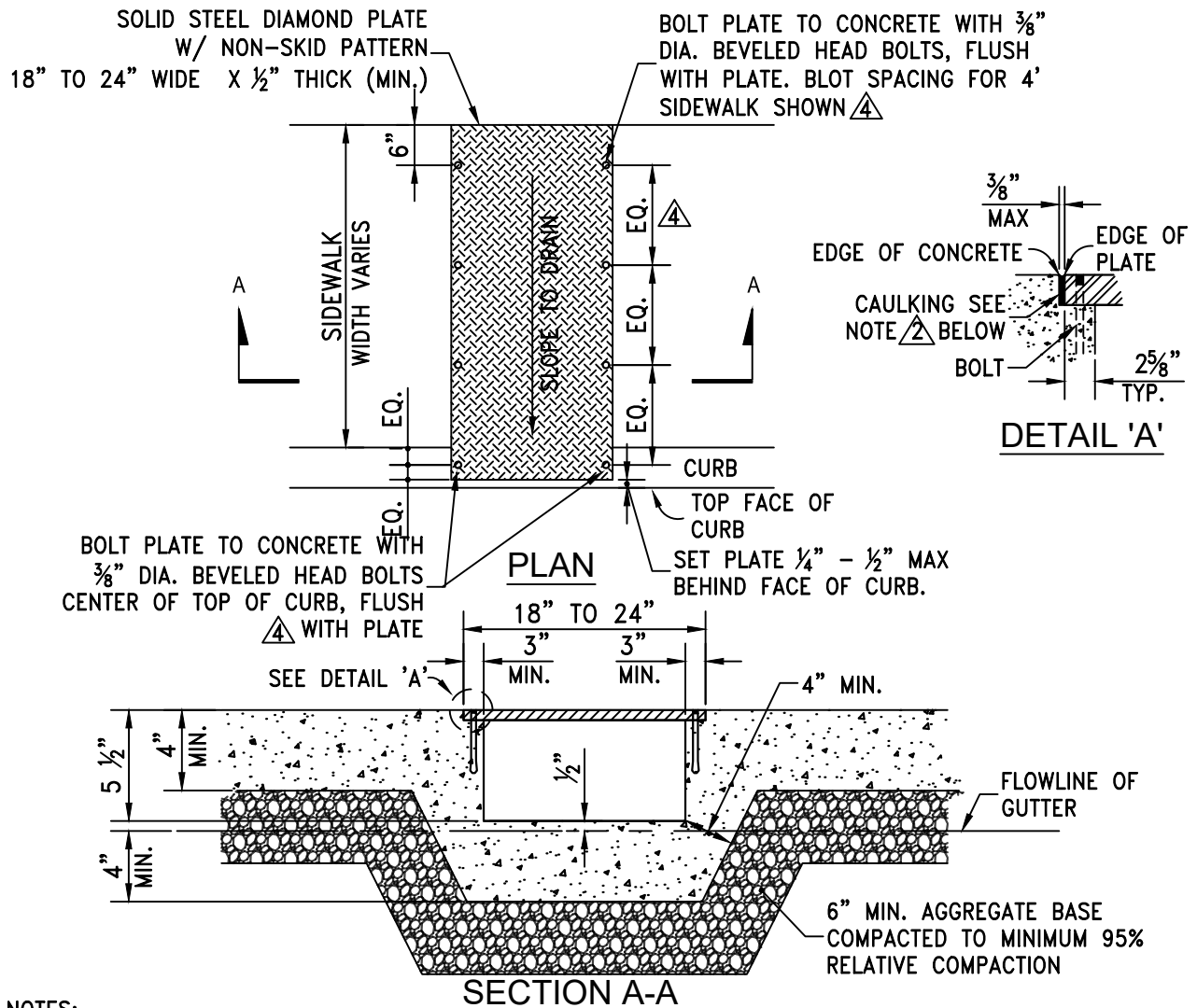

**NOTES:**

1. PORTLAND CEMENT CONCRETE (P.C.C.) SHALL BE 4000 PSI MIN. COMPRESSIVE STRENGTH AT 28 DAYS. ALL CEMENT CONCRETE SHALL HAVE A COARSE AGGREGATE GRADATION CONFORMING TO SIZE No. 67. POLYPROPYLENE OR CELLULOSE FIBERS SHALL BE ADDED TO THE P.C.C. AT 1.5 LBS PER CUBIC YARD. MIX DESIGN SHALL CONFORM TO THE REQUIREMENTS OF SECTION 337.10 OF SSPWC. ALL MATERIALS SHALL CONFORM TO SSPWC.
- $\triangle$  SET PLATE FLUSH WITH ADJACENT CONCRETE AND PROVIDE 3/8" MAX GAP BETWEEN STEEL PLATE AND EDGE OF SIDEWALK. FILL GAP WITH CAULKING AFTER PLACEMENT OF PLATE. CAULKING MATERIAL SHALL BE GE SILICONE II\* W/D SUPREME, OR APPROVED EQUAL. COLOR SHALL BE WHITE.
3. AGGREGATE BASE MATERIAL UNDER CONCRETE DRAIN SUPPORT STRUCTURE SHALL BE TYPE 2, CLASS B CRUSHED AGGREGATE, ALL MATERIALS SHALL CONFORM TO SSPWC SECTION 200.
- $\triangle$  BOLTS: 3/8" DIA x 2 7/8" LONG DYNABOLT SLEEVE ANCHOR RAMSET REDHEAD FS-3826 OR APPROVED EQUIVALENT. SIDEWALK WIDER THAN 4FT, BOLTS SHALL BE PLACED AT 18" O.C. FOR WIDTH OF SIDEWALK.
5. IF APPLICABLE, PRIORITIZE STOREY COUNTY SPECIFICATIONS.

SOURCE: CITY OF RENO DETAIL R-105

 <p>440 USA PKWY, SUITE 105 McCARRAN, NEVADA 89437</p>	DRAWN: _____ NT CHECKED: _____ CLR REV: _____ MAY 2024 REV: _____	STANDARD DETAIL	MISC.
	<h1>SIDEWALK CROSS DRAIN</h1>		<h2>7.2.1</h2>

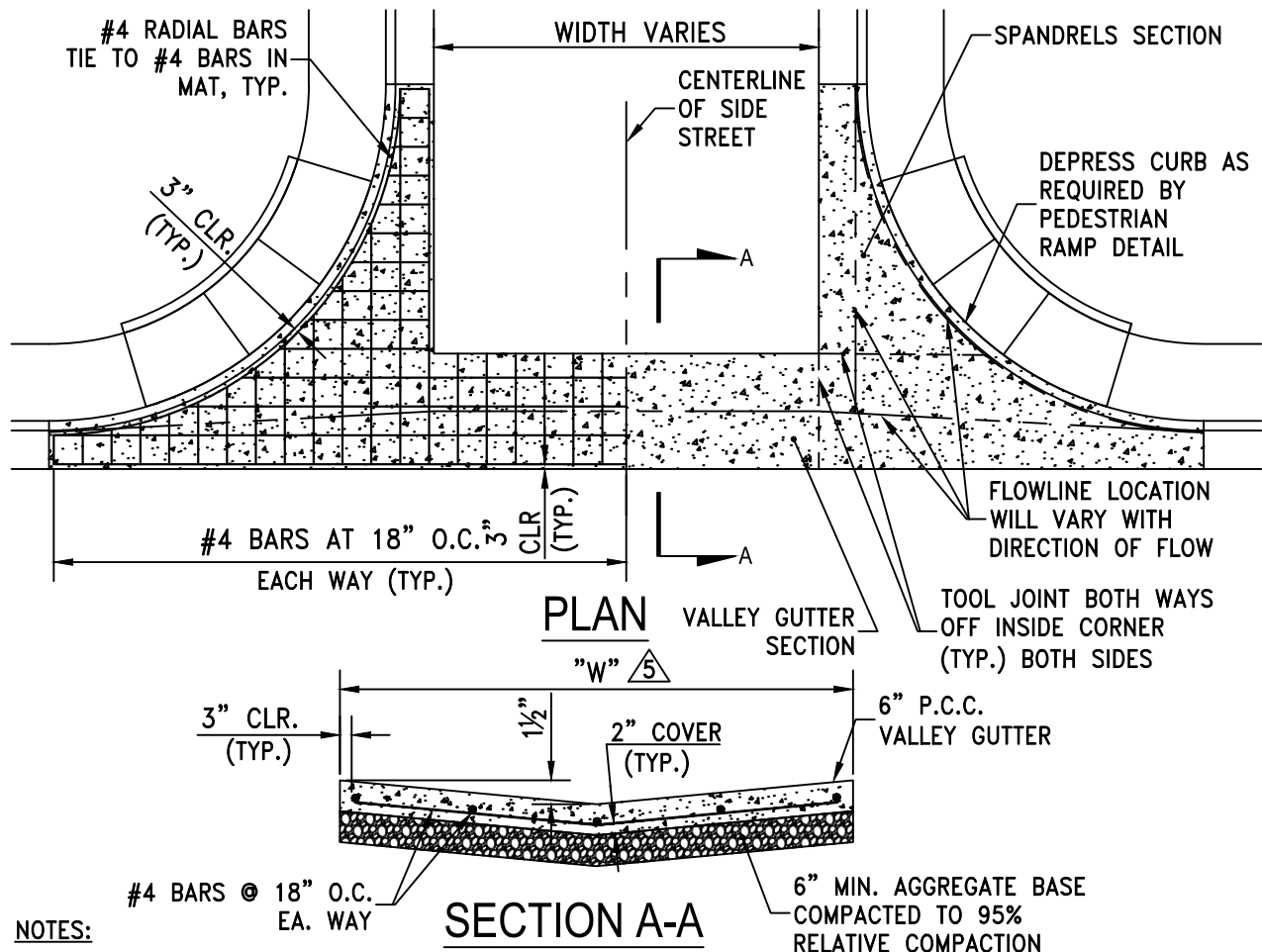

**NOTES:**

1. PORTLAND CEMENT CONCRETE (P.C.C.) SHALL BE 4000 PSI MIN. COMPRESSIVE STRENGTH AT 28 DAYS. ALL CEMENT CONCRETE SHALL HAVE A COARSE AGGREGATE GRADATION CONFORMING TO SIZE No. 67. POLYPROPYLENE OR CELLULOSE FIBERS SHALL BE ADDED TO THE P.C.C. AT 1.5 LBS PER CUBIC YARD. MIX DESIGN SHALL CONFORM TO THE REQUIREMENTS OF SECTION 337.10 OF SSPWC. ALL MATERIALS SHALL CONFORM TO SSPWC.
2. AGGREGATE BASE UNDER VALLEY GUTTER AND SPANDRELS SHALL BE TYPE 2, CLASS B CRUSHED AGGREGATE. ALL MATERIALS SHALL CONFORM TO SSPWC SECTION 200.
3. P.C.C VALLEY GUTTER DETAIL FOR COMMERCIAL ZONES ONLY FOR OTHER APPLICATIONS AN ENGINEERED DESIGN IS REQUIRED.
4. VALLEY GUTTER SHALL HAVE WEAKENED PLANE JOINTS EVERY 10 FEET.
5. LOCAL AND COLLECTOR STREETS, "W"=6' MIN. ARTERIAL STREETS (DRIVEWAYS ONLY), "W"=10' MIN.
6. VALLEY GUTTER SECTIONS (SPANDRELS) ALONG CURB & GUTTER MAY BE A MONOLITHIC POUR AS SHOWN. DOWELS MATCHING REBAR SPACING SHOWN ARE REQUIRED FROM VALLEY GUTTER SECTION TO SPANDREL SECTION IF POURED SEPARATELY.
7. IF APPLICABLE, PRIORITIZE STOREY COUNTY SPECIFICATIONS.

SOURCE: CITY OF RENO DETAIL R-107

 <p>440 USA PKWY, SUITE 105 McCARRAN, NEVADA 89437</p>	DRAWN: _____ NT CHECKED: _____ CLR REV: _____ MAY 2024 REV: _____	STANDARD DETAIL	MISC.
	<h1>PCC VALLEY GUTTER</h1>		<h2>7.3.1</h2>

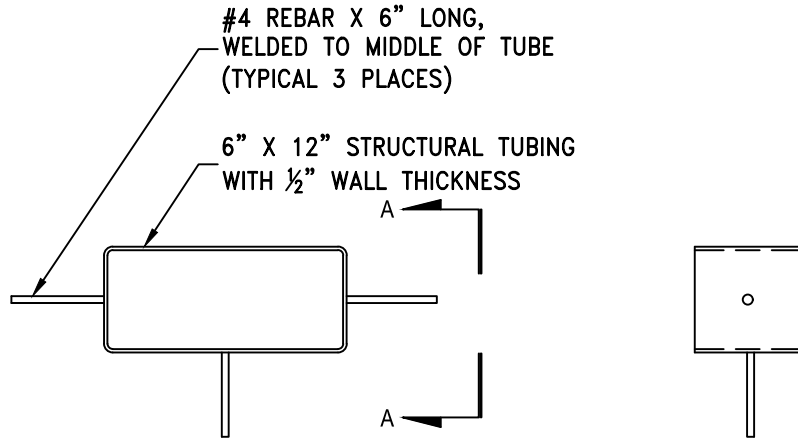

TUBING DETAIL

SECTION A-A

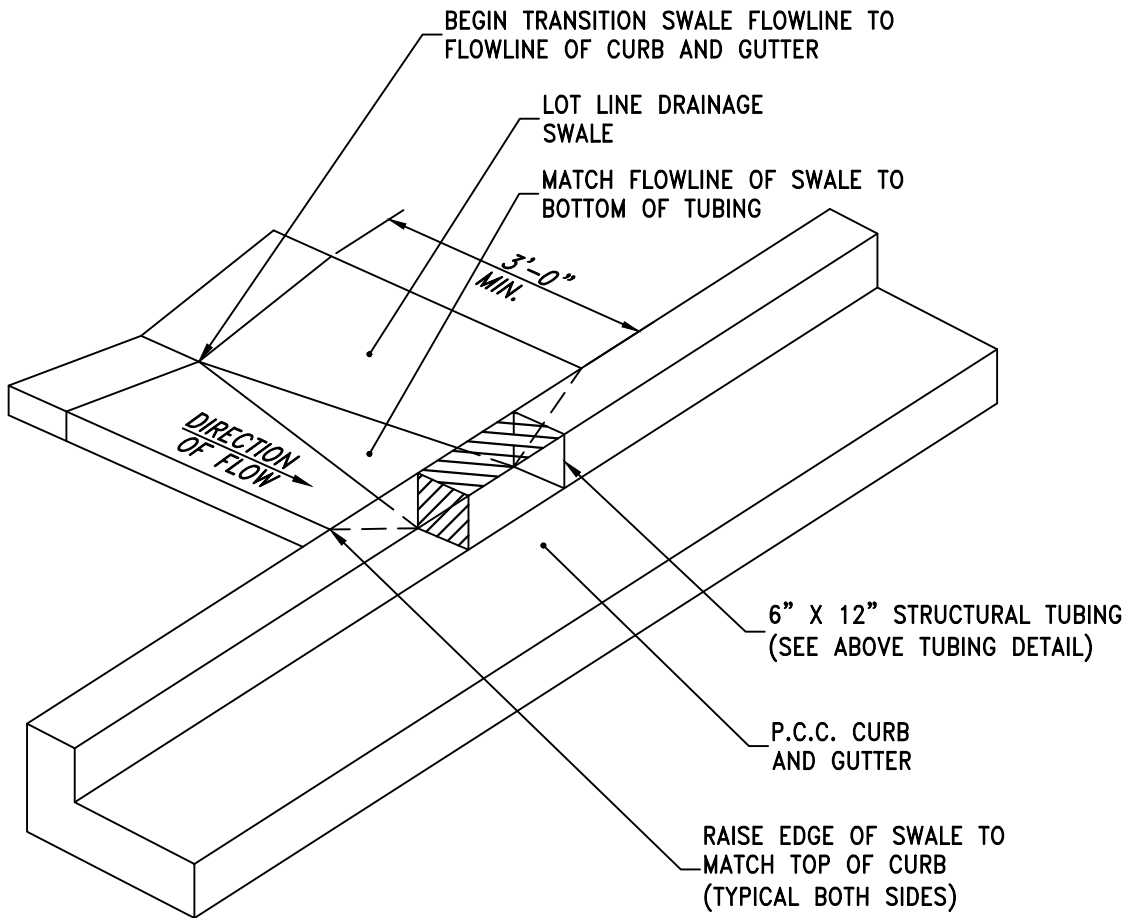

**NOTES:**

1. IF APPLICABLE, PRIORITIZE STOREY COUNTY SPECIFICATIONS.

SOURCE: CITY OF RENO DETAIL R-112



DRAWN: \_\_\_\_\_ NT  
 CHECKED: \_\_\_\_\_ CLR  
 REV: \_\_\_\_\_ MAY 2024  
 REV: \_\_\_\_\_

STANDARD DETAIL

MISC.

**CURB OPENING**

**7.4.1**

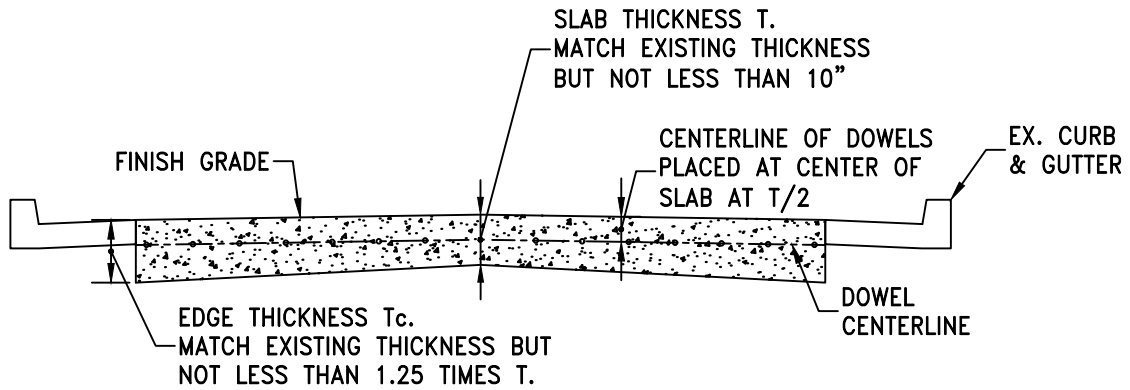
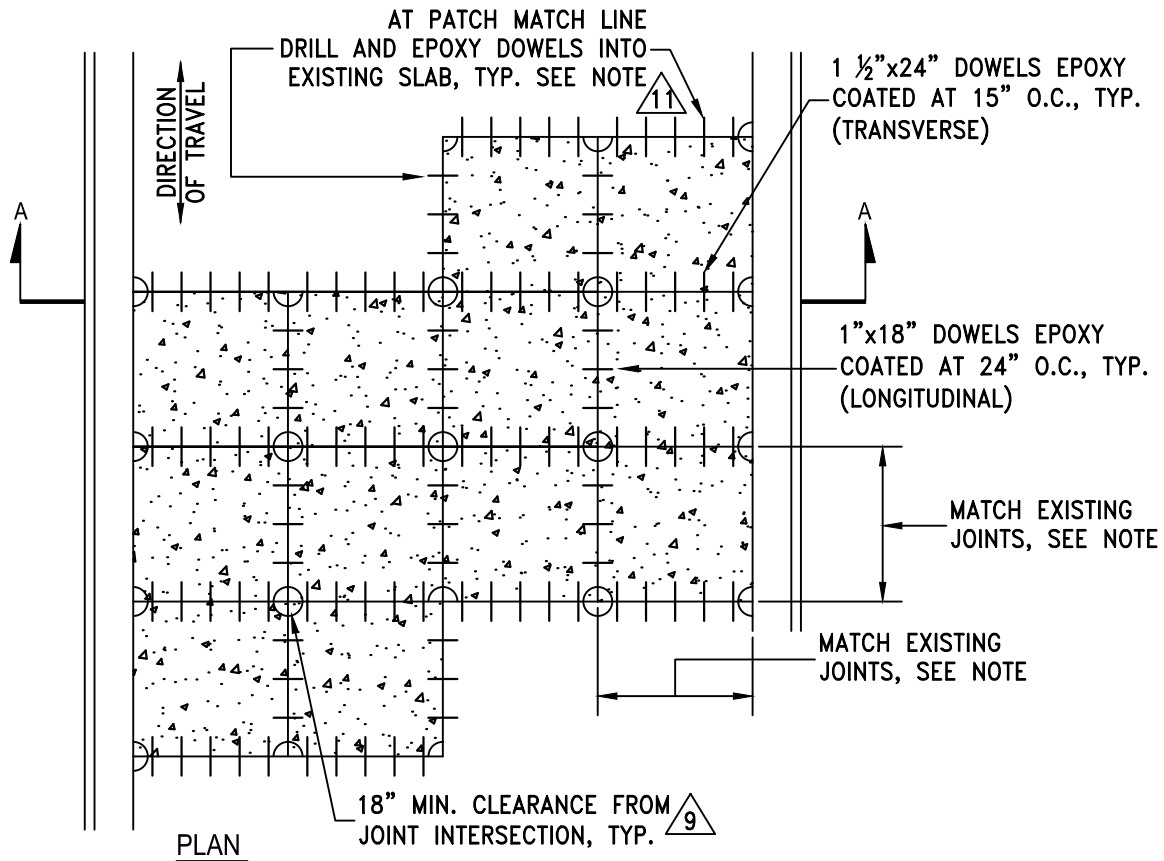

SECTION A-A

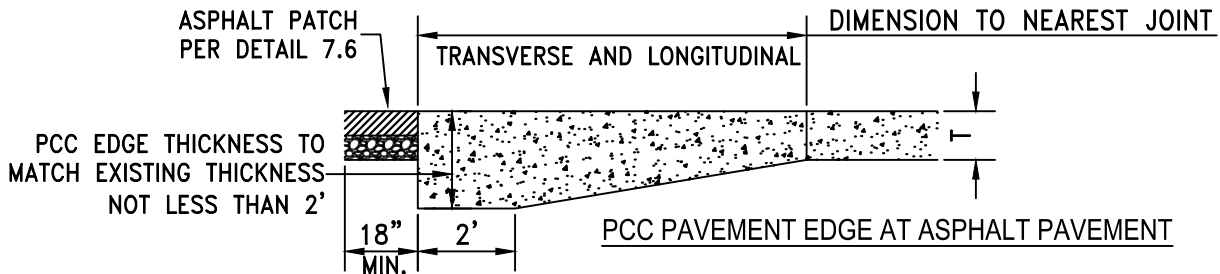

SOURCE: CITY OF RENO DETAIL R-119A



DRAWN: \_\_\_\_\_ NT  
CHECKED: \_\_\_\_\_ CLR  
REV: \_\_\_\_\_ MAY 2024  
REV: \_\_\_\_\_

STANDARD DETAIL

CONCRETE PAVEMENT  
PATCH

MISC.

7.5.1

**NOTES:**

1. TRIGID PERMANENT ASPHALT PATCH TO MATCH THE DEPTH OF THE CONTIGUOUS PAVEMENT, BUT NO LESS THAN 6 INCHES AND NO MORE THAN 8 INCHES.
2. AN ENCROACHMENT/EXCAVATION PERMIT MUST BE OBTAINED FROM STOREY COUNTY PUBLIC WORKS DEPARTMENT PRIOR TO CUTTING ANY PUBLIC RIGHT-OF-WAY.
3. ALL CONCRETE AND ASPHALT REMOVAL AND REPLACEMENT SHALL BE TO SAW-CUT LINES AND SHALL BE DONE BY EXCAVATION CONTRACTOR OR SUBCONTRACTOR. ALL SAW-CUTS SHALL BE VERTICAL AND IN STRAIGHT LINES PARALLEL OR PERPENDICULAR TO THE TRENCH OR TO THE SATISFACTION OF THE GID ENGINEER. CONCRETE PAVEMENT PATCH: IF SAW-CUT IS WITHIN 36" OF EDGE OR JOINT ON PCC PAVE, REMOVE PCC TO EXISTING EDGE AND REPLACE ENTIRE SECTION. ASPHALT PATCH: IF SAW-CUT IS WITHIN 36" OF EDGE OF PAVEMENT, EDGE OF VALLEY GUTTER, LIP OF CURB AND GUTTER, OR A PREVIOUS PATCH, REMOVE EXISTING PAVEMENT TO THAT EDGE AND REPLACE THE ENTIRE SECTION.
4. ALL CONCRETE SHALL BE A MINIMUM OF 6.25 SACKS OF TYPE II CEMENT (588 POUNDS PER CUBIC YARD OF CONCRETE) WITH FIBERMESH AND HAVE A MINIMUM COMPRESSIVE STRENGTH OF 4000 PSI AT 28 DAYS; AIR ENTRAINMENT TO BE 4.5-7.5%. REINFORCING SHALL CONSIST OF COLLATED, FIBRILLATED, POLYPROPYLENE FIBERS AS MANUFACTURED BY FIBERMESH OR APPROVED EQUAL AND SHALL BE ADDED AT A RATE OF 1½ LBS PER CUBIC YARD OF CONCRETE.
5. HOT MIX ASPHALT SHALL BE TYPE 3, PG64-28 (OR COUNTY APPROVED EQUIVALENT), 3% VOIDS, 50 BLOWS PER SIDE MIX WITH 1.5% LIME AND NO MORE THAN 15% RECYCLED ASPHALT PAVEMENT COMPACTED TO A MINIMUM OF 93% RICE RELATIVE COMPACTION.
6. ALL CONSTRUCTION SHALL BE IN ACCORDANCE WITH THE LATEST EDITION OF THE STANDARD SPECIFICATIONS FOR PUBLIC WORKS CONSTRUCTION.
7. DEPTH OF BASE TO BE 6" MINIMUM OR MATCH EXISTING BASE IF GREATER, INCLUDING UNPAVED STREETS.
8. CONCRETE SLURRY WITH MINIMUM OF 1 SACK OF CEMENT PER CUBIC YARD OF SLURRY OR OTHER APPROVED MIX DESIGN MAY BE USED FOR BASE COURSE, BEDDING OR BACKFILL IF APPROVED BY THE GID ENGINEER AND UTILITY COMPANIES.
9. PERMANENT RESURFACING SHALL NOT BE PLACED ON TRENCHES BACKFILLED WITH CONCRETE SLURRY FOR A MINIMUM OF 7 DAYS AFTER PLACEMENT OF THE CONCRETE SLURRY OR SIMILAR MATERIAL.
10. A NEGOTIATED RECONSTRUCTION, INCLUDING BUT NOT LIMITED TO GRIND AND OVERLAY, SHALL BE DETERMINED BY THE PUBLIC WORKS DEPARTMENT UPON THE EXTENT OF THE TRANSVERSE AND LONGITUDINAL EXCAVATIONS.
11. ALL PERMANENT PAVEMENT PATCHES REQUIRE ASPHALT SEAL COATS. THE TYPE SHALL BE DETERMINED BY THE STOREY COUNTY PUBLIC WORKS.
12. IF APPLICABLE, PRIORITIZE STOREY COUNTY SPECIFICATIONS.

SOURCE: CITY OF RENO DETAIL W-121B

 <p>440 USA PKWY, SUITE 105 McCARRAN, NEVADA 89437</p>	DRAWN: _____ NT CHECKED: _____ CLR REV: _____ MAY 2024 REV: _____	STANDARD DETAIL	MISC.
		<h2 style="text-align: center;">CONCRETE PAVEMENT PATCH NOTES</h2>	7.5A.1

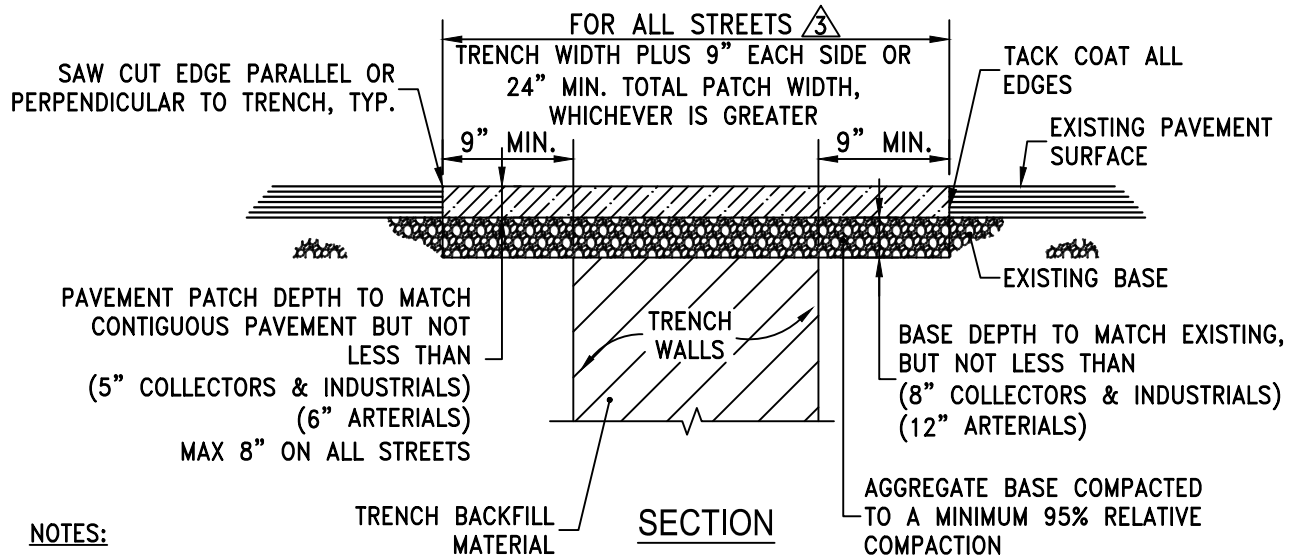

**NOTES:**

1. AN EXCAVATION/ENCROACHMENT PERMIT MUST BE OBTAINED FROM TRIGID PRIOR TO CUTTING ANY PUBLIC RIGHT-OF-WAY.
2. IF SAW CUT IS WITHIN 2 FEET OF AN EXISTING PAVEMENT EDGE OR EXISTING PAVEMENT PATCH, REMOVE EXISTING PAVEMENT TO THAT EDGE AND REPLACE ENTIRE SECTION.
3. ALL PERMANENT PATCH REPLACEMENT REQUIREMENTS ARE MINIMUM WIDTHS ONLY AND INCLUDES ALL AREAS WHERE THE ASPHALT PAVEMENT HAS BEEN UNDERMINED. THE STOREY COUNTY PUBLIC WORKS MAY REQUIRE WIDER PATCH SECTIONS OR OTHERWISE ALTER THESE REQUIREMENTS.
4. AGGREGATE BASE MATERIAL UNDER BITUMINOUS PAVEMENT PATCH SHALL BE TYPE 2, CLASS B CRUSHED AGGREGATE BASE. MATERIALS SHALL CONFORM TO SSPWC SECTION 200.
5. CONTRACTOR SHALL BE RESPONSIBLE FOR REPLACEMENT OF LOOP DETECTORS, ADJUSTMENT OF UTILITIES AND SURVEY MONUMENTS TO GRADE AND INSTALLATION OF PERMANENT PAVEMENT MARKINGS.
6. FOR P.C.C. CURB REPLACEMENT, SAW CUT EXISTING PAVEMENT 18 INCHES MIN. FROM GUTTER LIP LINE, REMOVE AND REPLACE PAVEMENT TO SAW CUT EDGES. CONCRETE MAY BE POURED NEAT AGAINST EXISTING EDGE OF ASPHALT IF APPROVED BY STOREY COUNTY PUBLIC WORKS.

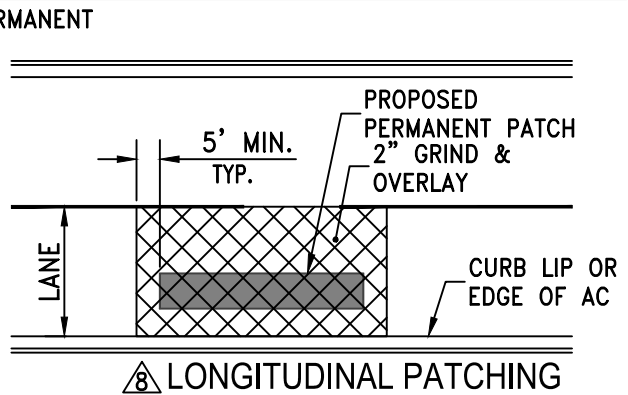
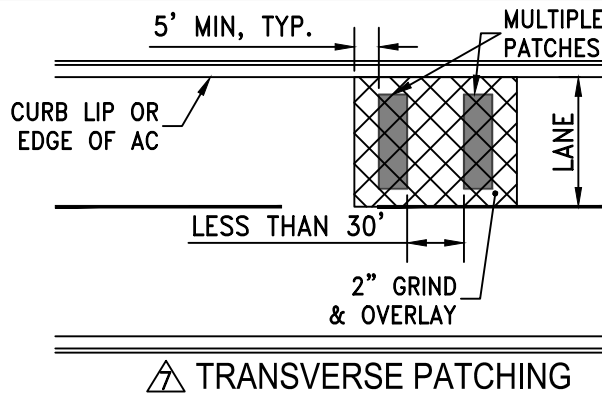

ALL STREETS WITH PAVEMENT CONDITION INDEX (PCI) GREATER THAN 65:

7. TRANSVERSE PATCHES SHALL INCLUDE A 2" GRIND AND OVERLAY WHEREVER THERE ARE MULTIPLE PATCHES WITHIN 30 FEET OF EACH OTHER.
8. LONGITUDINAL PATCHES SHALL INCLUDE 2" GRIND AND OVERLAY TO THE LANE LINES.
9. IF APPLICABLE, PRIORITIZE STOREY COUNTY SPECIFICATIONS.

SOURCE: CITY OF RENO DETAIL R-120



DRAWN: \_\_\_\_\_ NT  
 CHECKED: \_\_\_\_\_ CLR  
 REV: \_\_\_\_\_ MAY 2024  
 REV: \_\_\_\_\_

STANDARD DETAIL

## PERMANENT BITUMINOUS STREET PATCH

MISC.

# 7.6.1

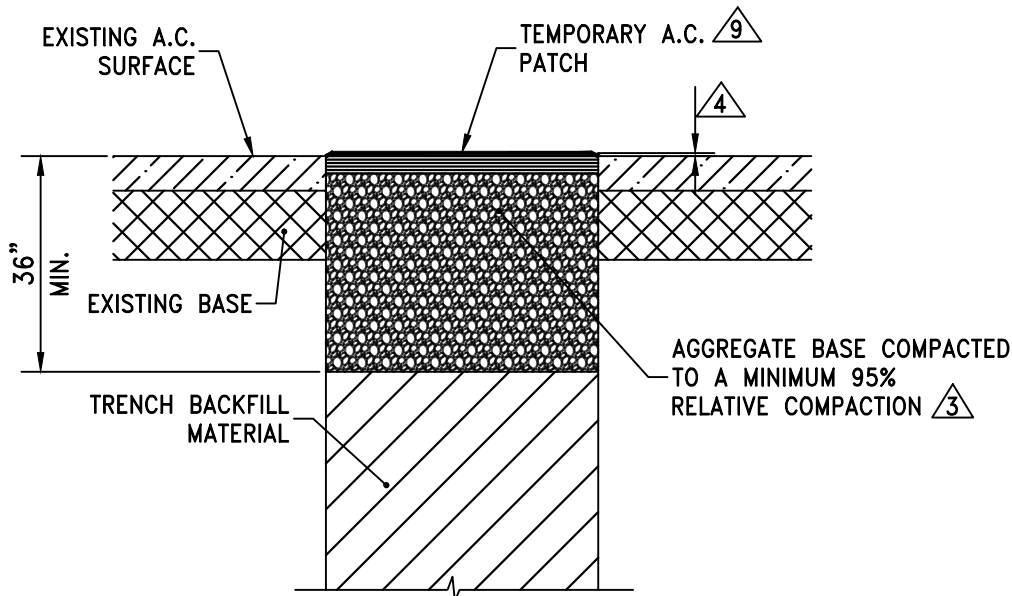

**NOTES:**

1. PRIOR TO EXCAVATION, THE OUTLINE OF THE TRENCH SHALL BE VERTICALLY CUT FULL DEPTH THROUGH THE EXISTING ASPHALT SURFACE.
2. CARE SHALL BE EXERCISED TO PREVENT SLOUGHING AND OVERBREAK. IF THE TRENCH SLOUGHS, THE SURFACE SHALL BE WIDENED TO ELIMINATE THE UNDERMINED SECTION OF ASPHALT.
3. AGGREGATE BASE UNDER TEMPORARY PATCH SHALL BE A MINIMUM THICKNESS OF 36 INCHES BELOW THE EXISTING AC SURFACE. AGGREGATE BASE MATERIAL UNDER TEMPORARY PATCH SHALL BE TYPE 2, CLASS B CRUSHED AGGREGATE BASE. MATERIALS SHALL CONFORM TO SSPWC SECTION 200.
4. TEMPORARY PATCHES SHALL BE PLACED AND COMPACTED. THE COMPACTED PATCH SHALL BE APPROXIMATELY 1/8" TO 1/4" ABOVE THE LEVEL OF THE ADJACENT PAVEMENT. IF NOT PATCHED WITHIN 24 HOURS AFTER BACKFILLING, THE COUNTY MAY PATCH AND BACK-CHARGE THE PERMITTEE FOR ALL COSTS.
5. COMPACTION OF BACKFILL, BASE AND A.C. TEMPORARY PATCH SHALL BE PERFORMED WITH APPROVED MECHANICAL TAMPERS. EQUIPMENT WHEEL ROLLING IS NOT PERMITTED.
6. ENTIRE AREA SHALL BE CLEANED OF ALL DIRT, DUST, DEBRIS, ETC. BEFORE LEAVING SITE. ANY SITE LEFT UNCLEANED WILL BE CLEANED BY THE COUNTY AND ALL COSTS BACK-CHARGED TO THE CONTRACTOR.
7. ALL EXCAVATIONS SHALL BE COMPLETE OR BACKFILLED AT THE END OF THE DAY.
8. TEMPORARY PATCH WORK AND PATCH MAINTENANCE SHALL BE THE RESPONSIBILITY OF THE CONTRACTOR.
9. ALL TEMPORARY PATCHES ON ALL STREETS SHALL BE HOT-MIX ASPHALT A MINIMUM OF 3" THICK.
10. IF APPLICABLE, PRIORITIZE STOREY COUNTY SPECIFICATIONS.

SOURCE: CITY OF RENO DETAIL R-121

 <p>440 USA PKWY, SUITE 105 McCARRAN, NEVADA 89437</p>	DRAWN: _____ NT CHECKED: _____ CLR REV: _____ MAY 2024 REV: _____	STANDARD DETAIL	MISC.
		<h1>TEMPORARY AC TRENCH PATCH</h1>	<h1>7.7.1</h1>



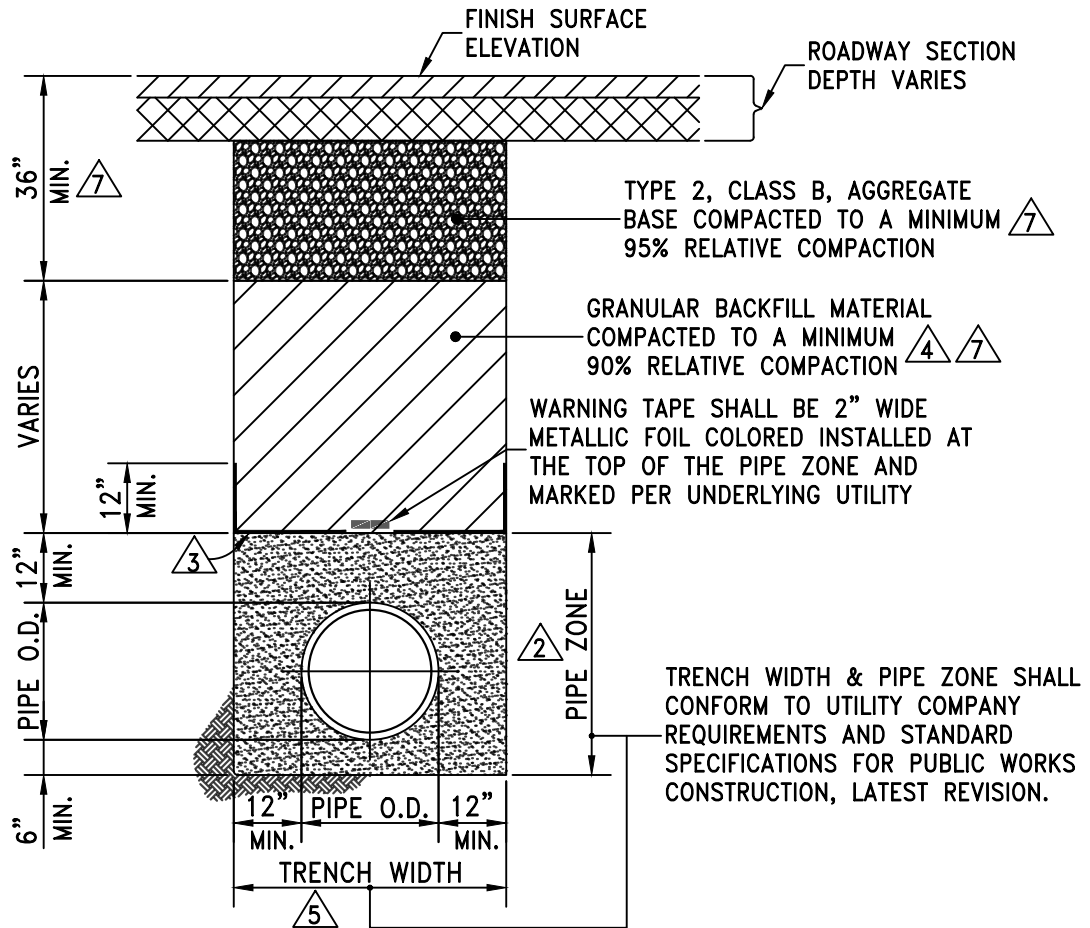

**NOTES:**

1. ALL MATERIALS AND INSTALLATION PROCEDURES SHALL BE IN ACCORDANCE WITH STANDARD SPECIFICATIONS FOR PUBLIC WORKS CONSTRUCTION (SSPWC), LATEST REVISION.
- <sup>2</sup>. BEDDING MATERIAL SHALL CONFORM TO OWNING-UTILITY COMPANY REQUIREMENTS AS APPROVED BY STOREY COUNTY. FOR TRIGID-OWNED UTILITIES, BEDDING MATERIAL SHALL BE CLASS A OR C, COMPACTED TO MINIMUM 90% RELATIVE COMPACTION. MATERIALS SHALL CONFORM TO SSPWC SECTION 200.
- <sup>3</sup>. CLASS C BEDDING REQUIRES INSTALLATION OF GEOTEXTILE FABRIC BETWEEN PIPE ZONE AND BACKFILL MATERIAL. GEOTEXTILE FABRIC SHALL BE MIRAFI 180N OR APPROVED EQUAL.
- <sup>4</sup>. BACKFILL MATERIAL SHALL BE TYPE 2, CLASS B OR CLASS E AND COMPACTED TO MINIMUM 90% RELATIVE COMPACTION. MATERIALS SHALL CONFORM TO SSPWC SECTION 200.
- <sup>5</sup>. ALL EXCAVATIONS SHALL CONFORM TO THE LATEST O.S.H.A. REQUIREMENTS.
6. EXISTING PIPE TO BE ABANDONED SHALL BE GROUT FILLED OR COMPLETELY REMOVED.
- <sup>7</sup>. MINIMUM BACKFILL DEPTH REQUIREMENT IS FOR TRENCHING IN EXISTING PAVED STREETS. TRENCHING FOR NEW DEVELOPMENT WHERE STREETS HAVE NOT YET BEEN CONSTRUCTED, BACKFILL MATERIAL SHALL BE TYPE 2, CLASS B OR CLASS E AND COMPACTED TO MINIMUM 90% RELATIVE COMPACTION. MATERIALS SHALL CONFORM TO SSPWC SECTION 200.
8. IF APPLICABLE, PRIORITIZE STOREY COUNTY SPECIFICATIONS.

SOURCE: CITY OF RENO DETAIL R-122



DRAWN: \_\_\_\_\_ NT  
 CHECKED: \_\_\_\_\_ CLR  
 REV: \_\_\_\_\_ MAY 2024  
 REV: \_\_\_\_\_

STANDARD DETAIL

MISC.

**TRENCH EXCAVATION  
 BACKFILL**

7.8.1

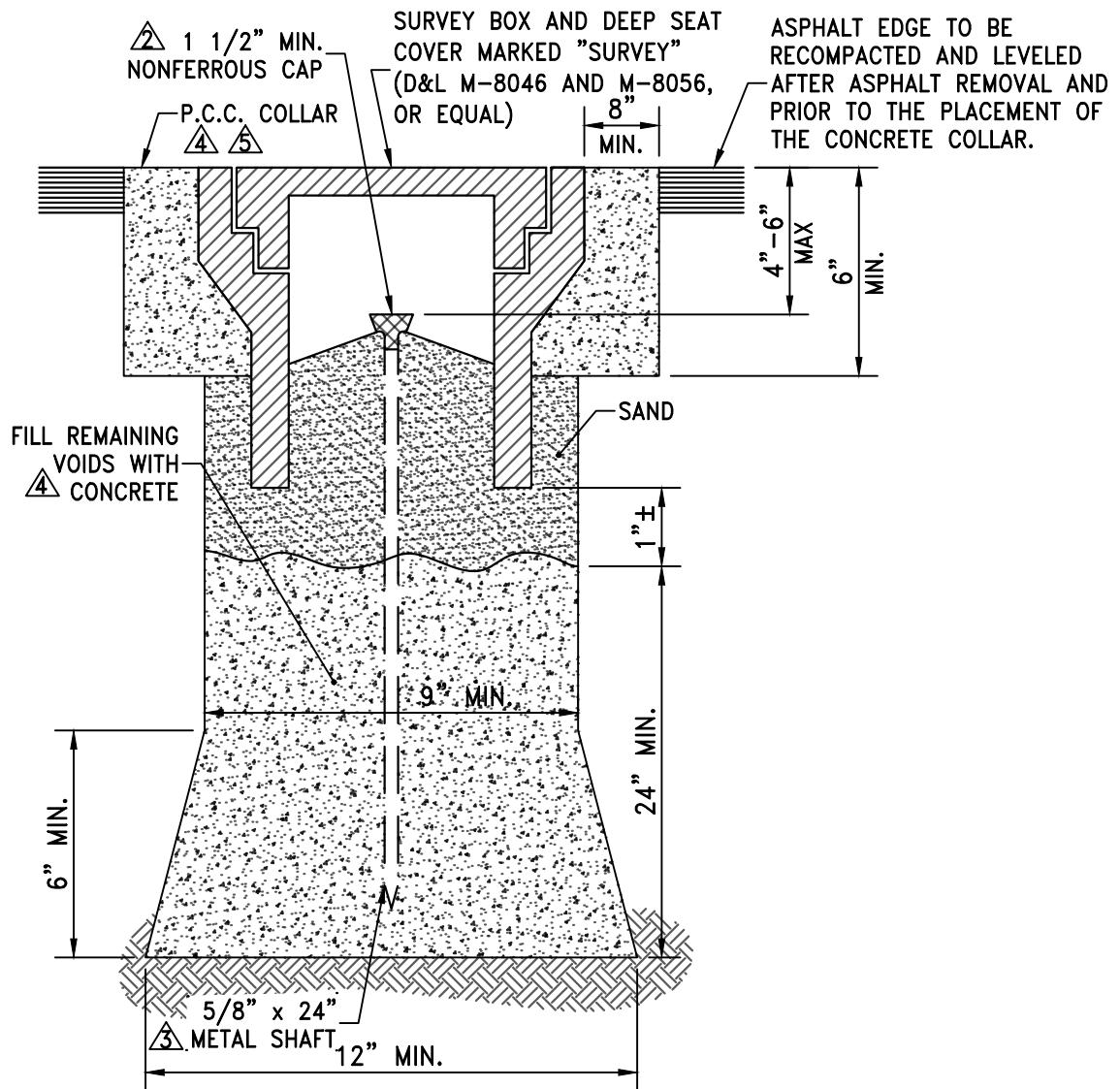

**NOTES:**

- 1. FERROUS METAL OVER MONUMENT FOR RECOVERY BY DIP NEEDLE OR MAGNETIC INSERT IN CAP.
- 2. 1 1/2" MIN. NONFERROUS CAP WITH PROFESSIONAL LAND SURVEYOR NO. PERMANENTLY ATTACHED PRIOR TO PLACEMENT. PRE-PUNCHED CAPS SHALL NOT BE PERMITTED
- 3. 5/8" METALLIC SHAFT (SMOOTH SHAFTS TO BE DEFORMED).
- 4. PORTLAND CEMENT CONCRETE (P.C.C.) SHALL BE 4000 PSI MIN. COMPRESSIVE STRENGTH AT 28 DAYS. ALL CEMENT CONCRETE SHALL HAVE A COARSE AGGREGATE GRADATION CONFORMING TO SIZE No. 67. POLYPROPYLENE OR CELLULOSE FIBERS SHALL BE ADDED TO THE P.C.C. AT 1.5 LBS PER CUBIC YARD. MIX DESIGN SHALL CONFORM TO THE REQUIREMENTS OF SECTION 337.10 OF SSPWC. ALL MATERIALS SHALL CONFORM TO SSPWC.
- 5. P.C.C. COLLARS IN ALL ROADWAYS SHALL BE PROTECTED FROM TRAFFIC LOADS UNTIL MINIMUM 3000 PSI IS ATTAINED.

6. IF APPLICABLE, PRIORITIZE STOREY COUNTY SPECIFICATIONS.

SOURCE: CITY OF RENO DETAIL R-124

 <p>440 USA PKWY, SUITE 105 McCARRAN, NEVADA 89437</p>	DRAWN: _____ NT CHECKED: _____ CLR REV: _____ MAY 2024 REV: _____	STANDARD DETAIL	MISC.
		<b>MONUMENTS</b>	<b>7.9.1</b>

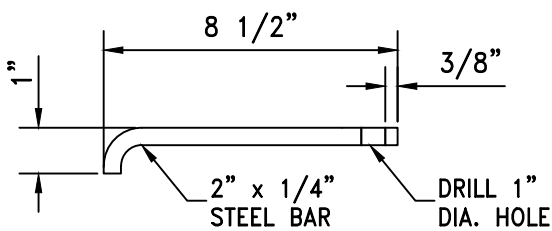
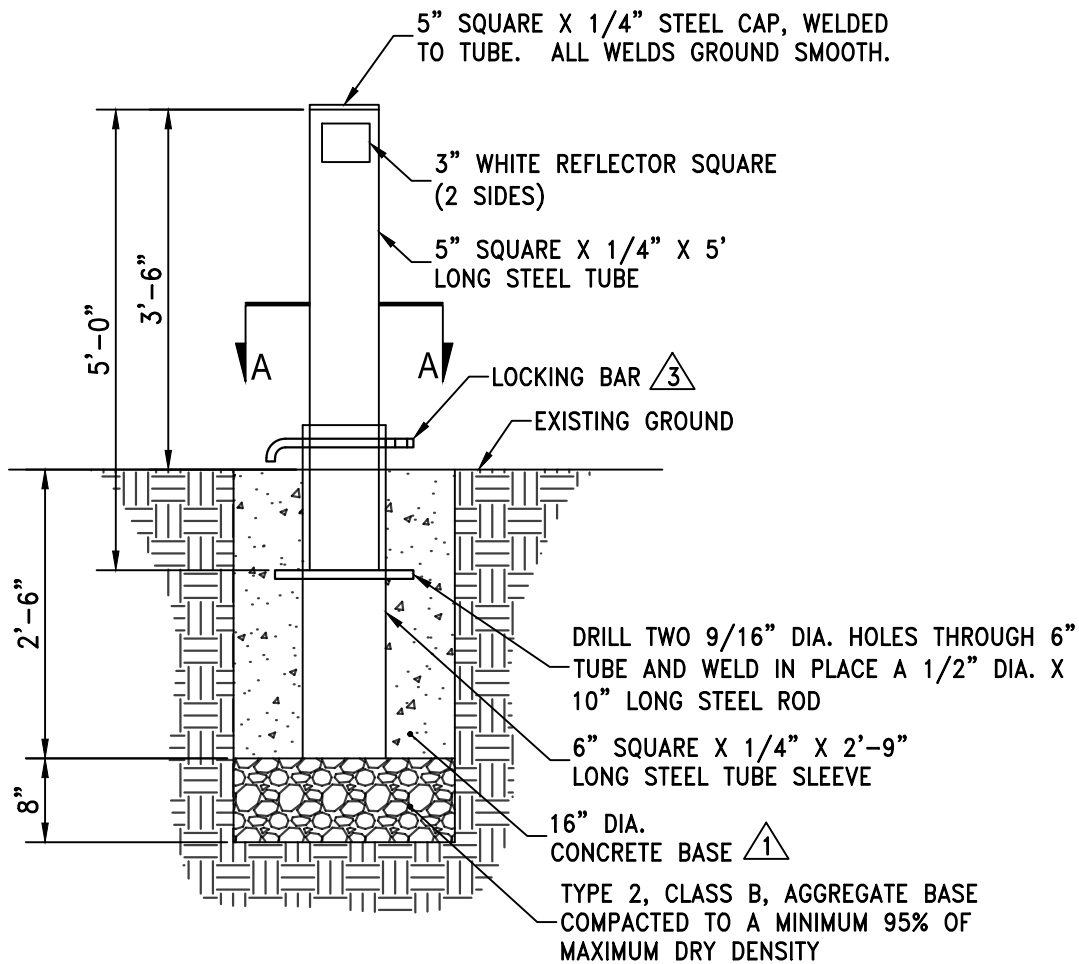

**LOCKING BAR**

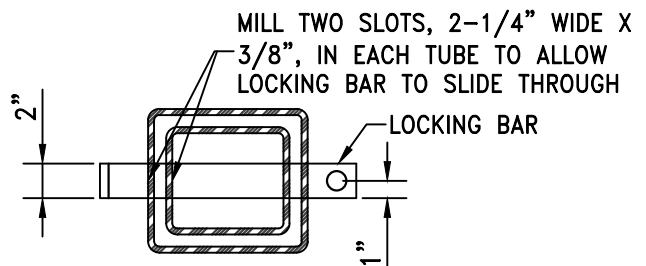

**SECTION A-A**

**NOTES:**

1. PORTLAND CEMENT CONCRETE (P.C.C.) SHALL BE 4000 PSI MIN. COMPRESSIVE STRENGTH AT 28 DAYS. ALL CEMENT CONCRETE SHALL HAVE A COARSE AGGREGATE GRADATION CONFORMING TO SIZE No. 67. POLYPROPYLENE OR CELLULOSE FIBERS SHALL BE ADDED TO THE P.C.C. AT 1.5 LBS PER CUBIC YARD. MIX DESIGN SHALL CONFORM TO THE REQUIREMENTS OF SECTION 337.10 OF SSPWC. ALL MATERIALS SHALL CONFORM TO SSPWC.
2. ALL WELDS AND BENDS SHALL BE SMOOTH, EVEN AND PAINTED.
3. TRIGID SHALL PROVIDE THE PADLOCK AND MAINTAIN THE KEYS.
4. IF APPLICABLE, PRIORITIZE STOREY COUNTY SPECIFICATIONS.

SOURCE: CITY OF RENO DETAIL R-603A



DRAWN: \_\_\_\_\_ NT  
 CHECKED: \_\_\_\_\_ CLR  
 REV: \_\_\_\_\_ MAY 2024  
 REV: \_\_\_\_\_

STANDARD DETAIL

MISC.

**REMOVABLE BOLLARD**

7.10.1

STERNBERG - RICHMOND  
 QUICK RELEASE BOLLARD  
 #390/B/QR/VG  
 COLOR: VERDE GREEN

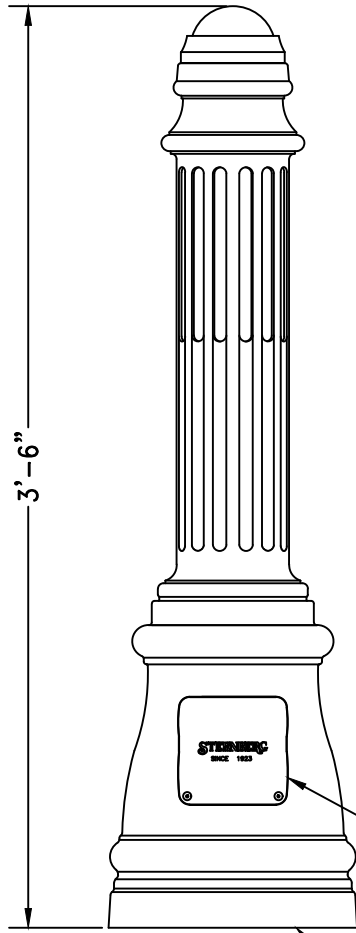

11½" DIA. BASE .750  
 FLOOR THICKNESS 4  
 ANCHOR BOLTS

ACCESS DOOR WITH FLUSH  
 STAINLESS STEEL ALLEN  
 HEAD SCREWS.

NOTES:

1. GENERAL  
 THE BOLLARD SHALL BE CAST ALUMINUM, ONE-PIECE CONSTRUCTION. THE 11½" DIAMETER CAST ALUMINUM FLUTED BASE SHALL BE CONSTRUCTED WITH A 5¼" DIAMETER STRAIGHT FLUTED CAST ALUMINUM SHAFT. THE MODEL SHALL BE STERNBERG LIGHTING #390B-QR QUICK RELEASE UNIT BOLLARD, RICHMOND.
2. CONSTRUCTION  
 THE BASE SHALL BE DESIGNED WITH A SCULPTURE BELL SHAPED BOTTOM, FOURTEEN FLUTE TOP SECTION AND BE MADE OF HEAVY 356 ALLOY CAST ALUMINUM. IT SHALL HAVE A ¾" THICK FLOOR CAST AS AN INTEGRAL PART OF THE BASE. THE BOLLARD CAP SHALL BE WELDED IN PLACE. THE OVERALL HEIGHT OF THE BOLLARD SHALL BE 42".
3. QUICK RELEASE MOUNT  
 THE MODEL 390B-QR SHALL HAVE A QUICK RELEASE OPTION WHICH ALLOWS QUICK REMOVAL OF THE BOLLARD FOR CONVENIENCE OR EMERGENCY ACCESS. THE BURIAL PORTION SHALL BE MADE OF ASTM 6061 ALUMINUM EXTRUSION AND SHALL HAVE A KEYWAY AND FLEXIBLE CONNECTION SYSTEM FOR SECURING TO BOLLARD. THE BOLLARD SHALL HAVE A MATED EXTENSION AND ANTI-ROTATION KEY AND PADLOCK SLOT. THE QUICK RELEASE SYSTEM SHALL ALLOW FOR A FLUSH PAVEMENT INSTALLATION AFTER TEMPORARY BOLLARD REMOVAL.
4. FINISH  
 OUR OPTIONAL ANTIQUE VERDE GREEN FINISH ARE HAND BRUSHED USING A 3-STEP PROCESS. THE TOTAL ASSEMBLY SHALL BE WRAPPED IN SHOCKPROOF WRAPPING OR FULLY ENCLOSED IN CORRUGATED CARTONS.
5. INSTALLATION
6. FOUR, HOT DIPPED GALVANIZED "L" TYPE ANCHOR BOLTS SHALL BE PROVIDED WITH THE POST FOR NON-QUICK RELEASE BOLLARD ANCHORAGE. QUICK RELEASE ANCHORAGE REQUIRES NO ANCHOR BOLTS. A DOOR SHALL BE PROVIDED FOR ANCHOR BOLT ACCESS. IT SHALL BE SECURED WITH TAMPER PROOF, STAINLESS STEEL HARDWARE.
7. PLACE ACCESS DOOR AWAY FROM STREET.
8. IF APPLICABLE, PRIORITIZE STOREY COUNTY SPECIFICATIONS.

SOURCE: CITY OF RENO DETAIL R-603B



DRAWN: \_\_\_\_\_ NT  
 CHECKED: \_\_\_\_\_ CLR  
 REV: \_\_\_\_\_ MAY 2024  
 REV: \_\_\_\_\_

STANDARD DETAIL

MISC.

DECORATIVE BOLLARD

7.11.1